

XGC****-XL FINISHED GOODS ONLY

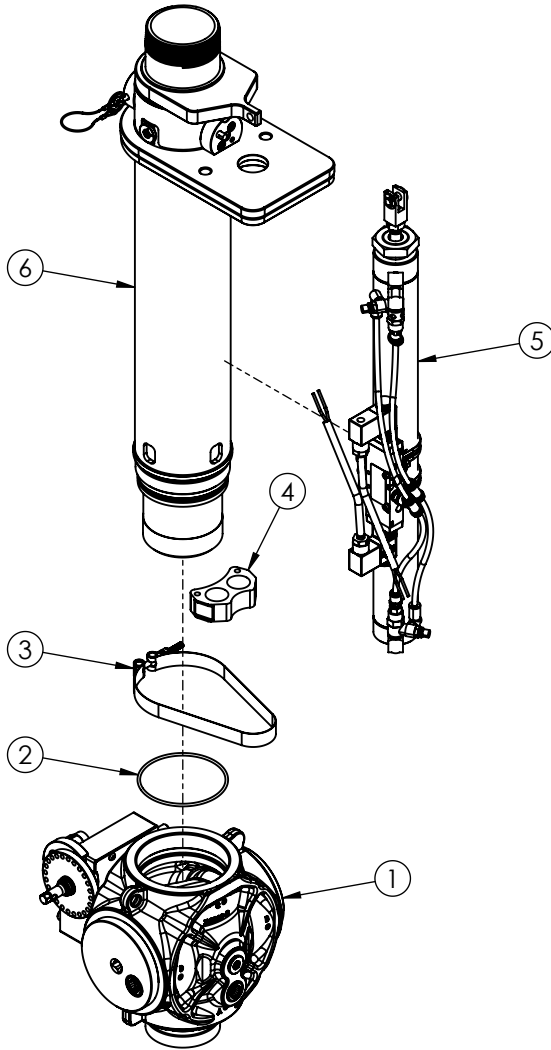

ITEM NO.	PART NUMBER	DESCRIPTION	QTY.
1	XGC910	XGVP VALVE SUBASSEMBLY	1
2	VO-242	O-RING 242	1
3	XG335	TIGHT-SEAL STAINLESS STEEL BOLT CLAMP	1
4	XG336	SADDLE	1
5	XGC905	XGVP PNEUMATICS SUBASSEMBLY	1
6	XGC900XL	XGVP TUBES CODE-RLM SUBASSEMBLY	1
7	XGC901	3"NPTF X CROSSFIRE SUBASSEMBLY	1

ITEM NO. 6 (ADDITIONAL TUBE SUBASSEMBLY OPTION)

XGC900PL
XGVP TUBES 3.0"NPTM SUBASSEMBLY

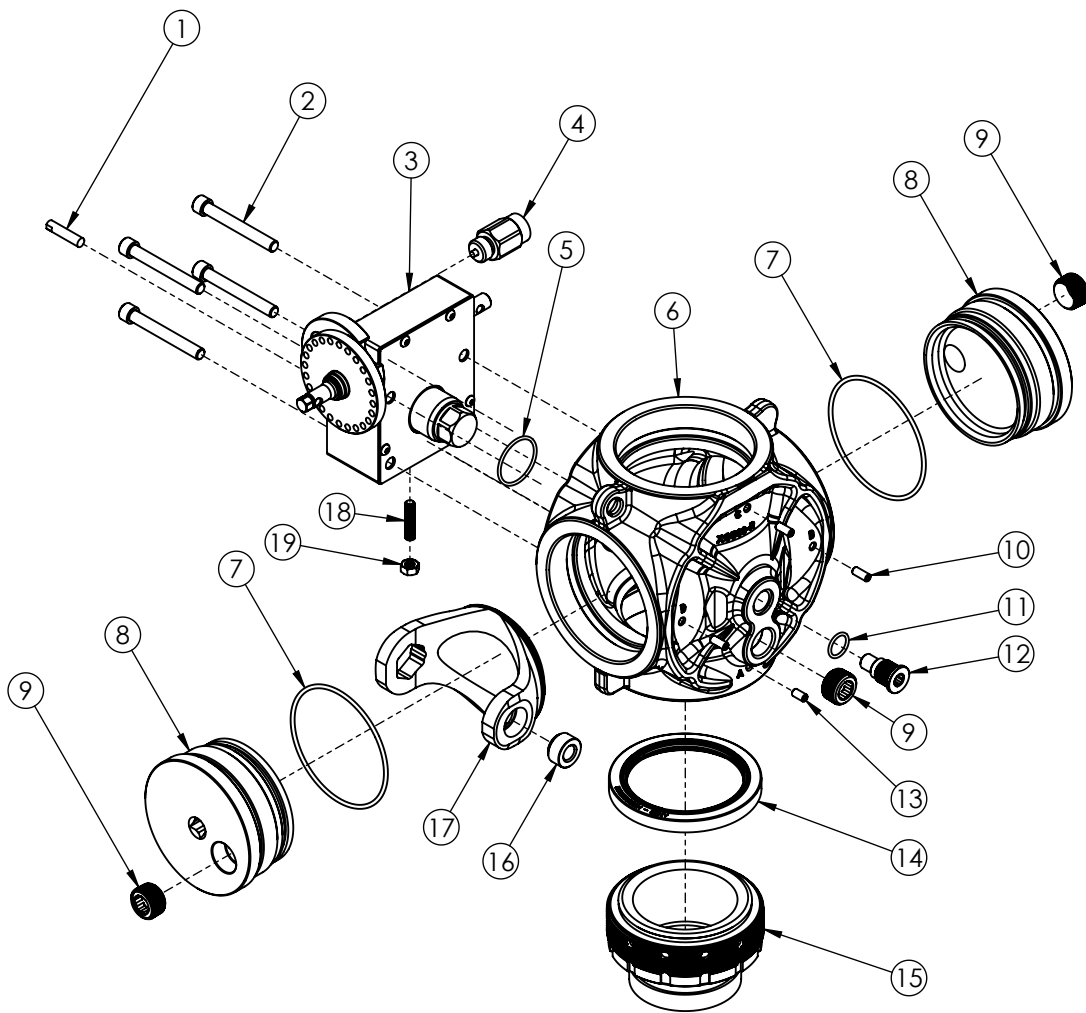

ITEM NO.	PART NUMBER	DESCRIPTION	QTY.
1	XGC903	REED SWITCH - SUBASSEMBLY	1
2	VT37-16SH3.0	3/8-16 X 3 SOCKET HEAD CAP SCREW	4
3	XGC911	XGVP GEARBOX SUBASSEMBLY	1
4	XGC902	SOLENOID - SUBASSEMBLY	1
5	VO-128	O-RING 128	1
6	XG300	VALVE BODY XG 3"	1
7	VO-242	O-RING 242	2
8	XG303	BLIND PLUG SHORT	2
9	XG410	3/4"NPTM HEX SOCKET PLUG	3
10	VT25-20SS625	1/4-20 X 5/8 SOCKET SET SCREW CUP POINT	3
11	VO-115	O-RING 115	1
12	AY357	LOWER TRUNNION - NO HEX	1
13	VT25-20SS500	1/4-20 X 1/2 SOCKET SET SCREW CUP POINT	1
14	A1520	VALVE SEAT	1
15	XG304VL	SEAT RETAINER 3" VICTAULIC	1
16	A2095	BUSHING FOR ALUM HALF BALL	1
17	A1043A	HALF BALL 5.5" ALUM NO DRAIN	1
18	VTM8-125FP35	M8-125 X 35 MM SET SCREW FLAT POINT	1
19	VTM8-125NT	M8-1.25 HEX NUT	1

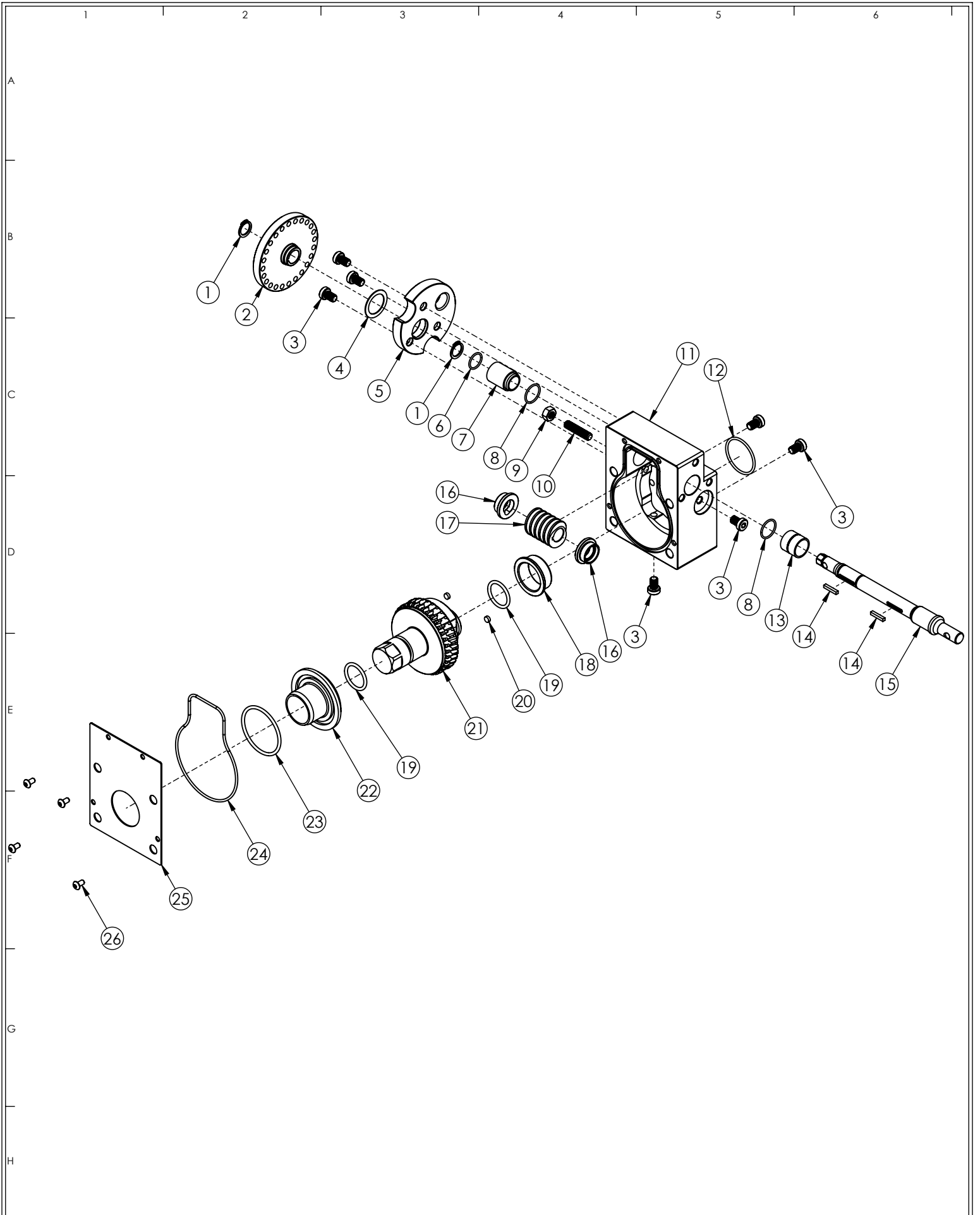

LXX-012

PARTS LIST: EXTEND-A-GUN VP
 MAINTENANCE AND SERVICE

SHEET: 3 of 8
 REV: 2
 DATE: 5/13/22



TASK FORCE TIPS, LLC.
 3701 INNOVATION WAY
 VALPARAISO, IN 46383 USA
 (219)462-6161

A
B
C
D
E
F
G
H

ITEM NO.	PART NUMBER	DESCRIPTION	QTY.
1	VR4275	RETAINING RING	2
2	XG314	SPROCKET FOR SOLENOID	1
3	VTM8-125LH12	M8-1.25 X 12 MM LOW SOCKET HEAD SCREW	7
4	P170	TEFLON TRUNNION SHIM	1
5	XG313	BRACKET FOR SOLENOID	1
6	VO-016	O-RING 016	1
7	A1528	BUSHING	1
8	VO-018	O-RING 018	2
9	VTM8-125NT	M8-1.25 HEX NUT	1
10	VTM8-125FP35	M8-125 X 35 MM SET SCREW FLAT POINT	1
11	XG308	GEARBOX	1
12	VO-128	O-RING 128	1
13	A1527	THIN BUSHING	1
14	Y6121	KEY	2
15	XG311	SHAFT	1
16	A1531	WORM THRUST WASHER	2
17	x220	12 DP WORM	1
18	A1538	BUSHING	1
19	VO-214	O-RING 214	2
20	VM4170	MAGNET	2
21	XG310	TRUNNION WORM DRIVE	1
22	A1511	GEAR SPACER	1
23	VO-226	O-RING 226	1
24	VO-156	O-RING-156	1
25	XG309	GEARBOX COVER	1
26	VT10-24BH375	10-24 X 3/8 BUTTON HEAD CAP SCREW	4



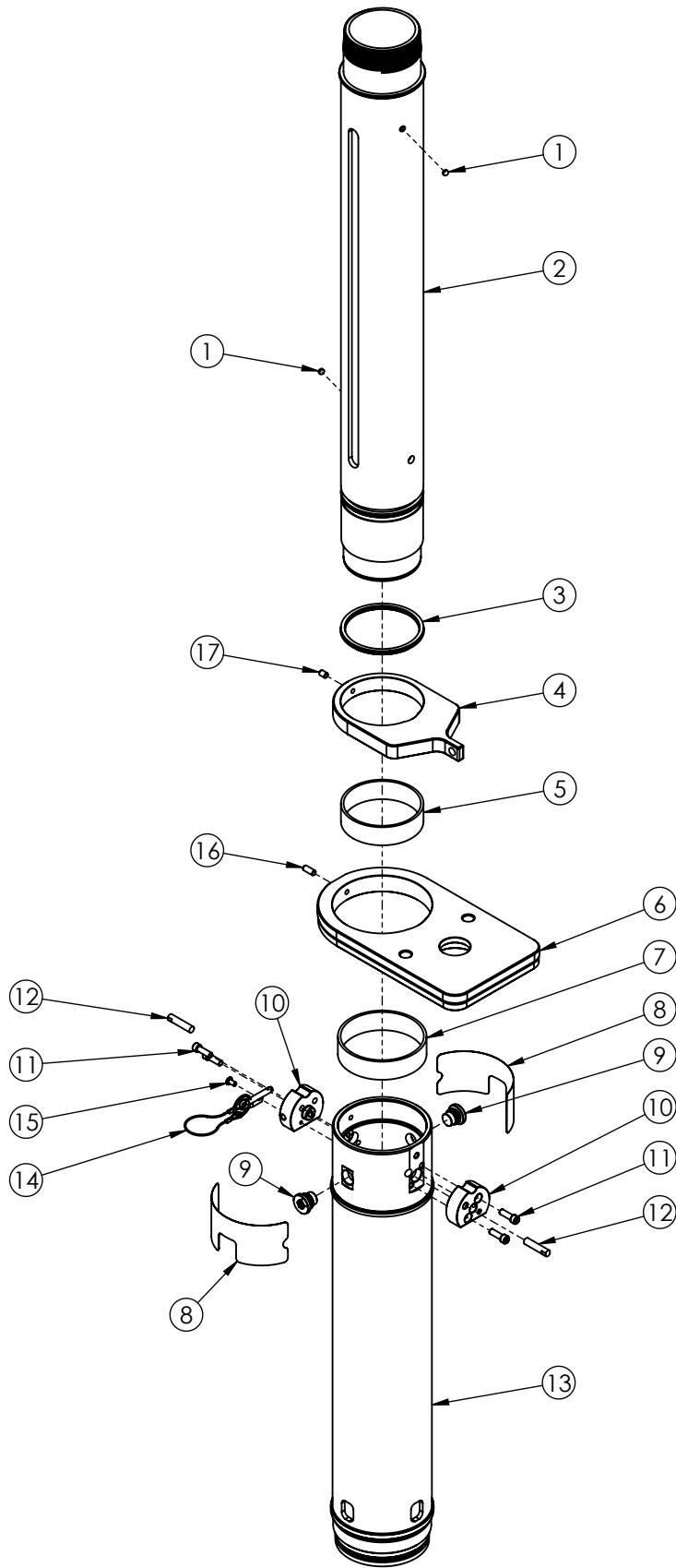

ITEM NO.	PART NUMBER	DESCRIPTION	QTY.
1	VM4170	MAGNET	2
2	XG328PL	18" INNER TUBE 3.0"NPT MALE	1
3	XG125	CUP SEAL	1
4	XG306	UPPER BRACKET	1
5	XG327	O.D. WEAR SURFACE BEARING	1
6	XG307	LOWER BRACKET	1
7	XG326	I.D. WEAR SURFACE BEARING	1
8	XG316	NAME LABEL: EXTEND-A-GUN VP	2
9	XG305	STOP SCREW	2
10	XG315	BRACKET FOR REED SWITCH	2
11	VT25-28SH750	1/4-28 X 3/4 SOCKET HEAD CAP SCREW	4
12	XGC903	REED SWTCH - SUBASSEMBLY	2
13	XG301	OUTER TUBE 18" RISE FOR VALVE	1
14	VM4621	QUICK-RELEASE PIN WITH LANYARD	1
15	VT10-24BH375	10-24 X 3/8 BUTTON HEAD CAP SCREW	1
16	VT25-28SS625	1/4-28 X 5/8 SOCKET SET SCREW CUP POINT	1
17	VT25-28SS375	1/4-28 X 3/8 SOCKET SET SCREW CUP POINT	1

ITEM NO. 2 (ADDITIONAL INNER TUBE OPTION)
XG328XL 18" INNER TUBE CODE-RLM



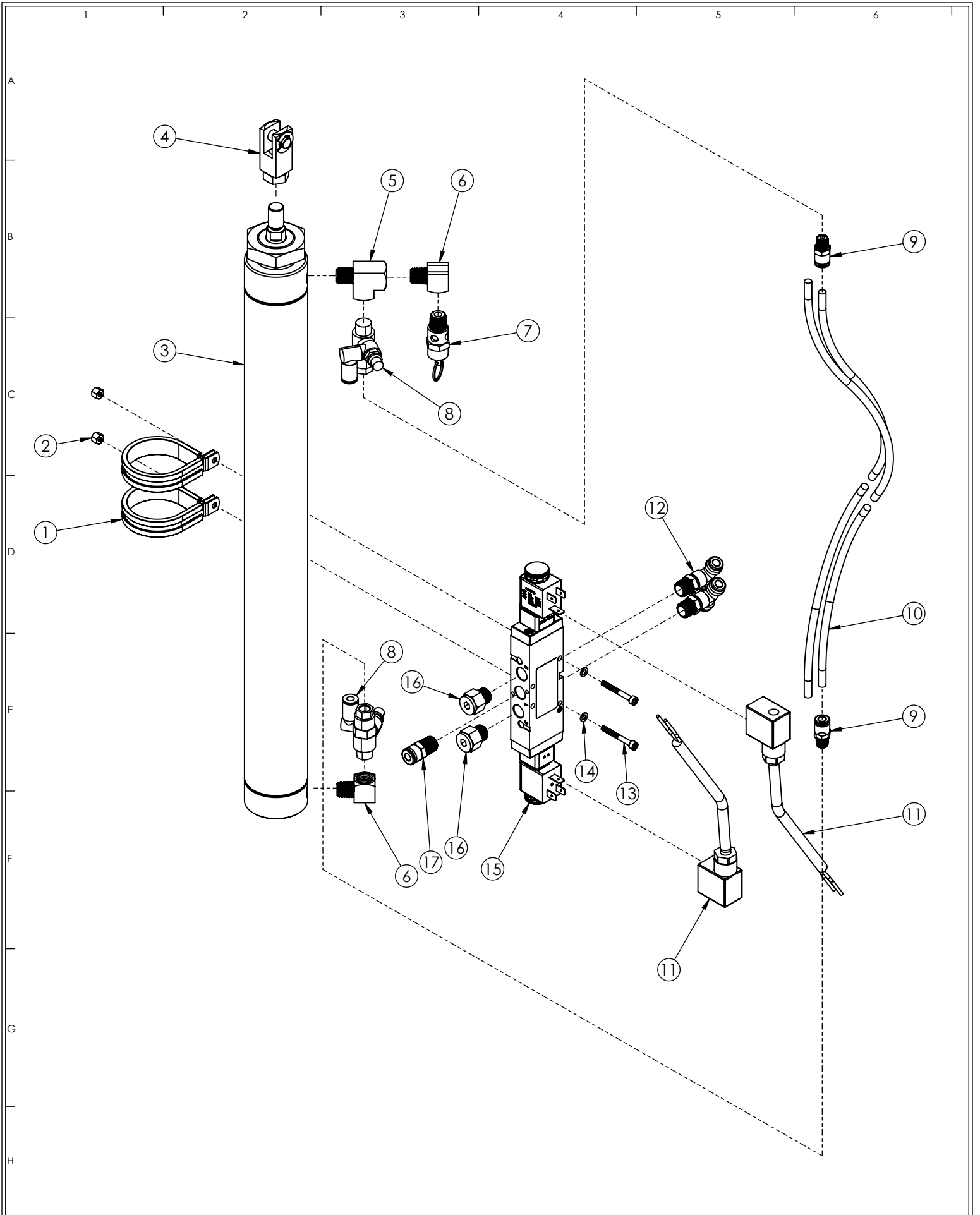

LXX-012

PARTS LIST: EXTEND-A-GUN VP
 MAINTENANCE AND SERVICE

SHEET: 7 of 8
 REV: 2
 DATE: 5/13/22



TASK FORCE TIPS, LLC.
 3701 INNOVATION WAY
 VALPARAISO, IN 46383 USA
 (219)462-6161

1 2 3 4 5 6

A
B
C
D
E
F
G
H

ITEM NO.	PART NUMBER	DESCRIPTION	QTY.
1	XG333	P-LOOP CLAMP 2" ID	2
2	XG334	STANDOFF M4-0.7 X 6MM LG. 8MM HEX	2
3	XG330	AIR CYLINDER W/ NUT 2"BORE DOUBLE ACTING	1
4	XG331	CLEVIS FOR AIR CYLINDER	1
5	VFST2FX2MX2F	1/4"NPTF X 1/4"NPTM - TEE W/SEALANT	1
6	VFSL2FX2M-90	1/4"NPTF X 1/4"NPTM -BRS 90DEG W/SEALANT	2
7	VM4605	FAST ACTING RELIEF VALVE 150 PSI 1/4 NPT	1
8	VM4602	SPEED CONTROLLER, NPT 1/2 IN - 1/4IN OUT	2
9	VFAA2LX1M	PUSH-TO-CONNECT FITTING 1/8 NPT 1/4 TUBE	2
10	VM4604	SAE J844 TYPE A AIR TUBING 1/4 OD	1
11	XGC907	XGVP WIRING HARNESS SUBASSEMBLY	2
12	VFHT2LX2LX2M	PUSH-TO-CONNECT FITTING 1/4 NPT 1/4 TUBE	2
13	VTM4R0.7SH35	M4-0.7 X 35MM SOCKET HEAD CAP SCREW	2
14	VW312X175-30	WASHER	2
15	VM4600	DOUBLE SOLENOID OPERATED VALVE XTREME	1
16	VM4603	EXHAUST PROTECTOR 1/4 NPT	2
17	VFAA2LX2M	PUSH-TO-CONNECT FITTING 1/4 NPT 1/4 TUBE	1

LXX-012

PARTS LIST: EXTEND-A-GUN VP
MAINTENANCE AND SERVICE

SHEET: 8 of 8
REV: 2
DATE: 5/13/22



TASK FORCE TIPS, LLC.
3701 INNOVATION WAY
VALPARAISO, IN 46383 USA
(219)462-6161