

1 2 3 4 5 6

A  
B  
C  
D  
E  
F  
G  
H

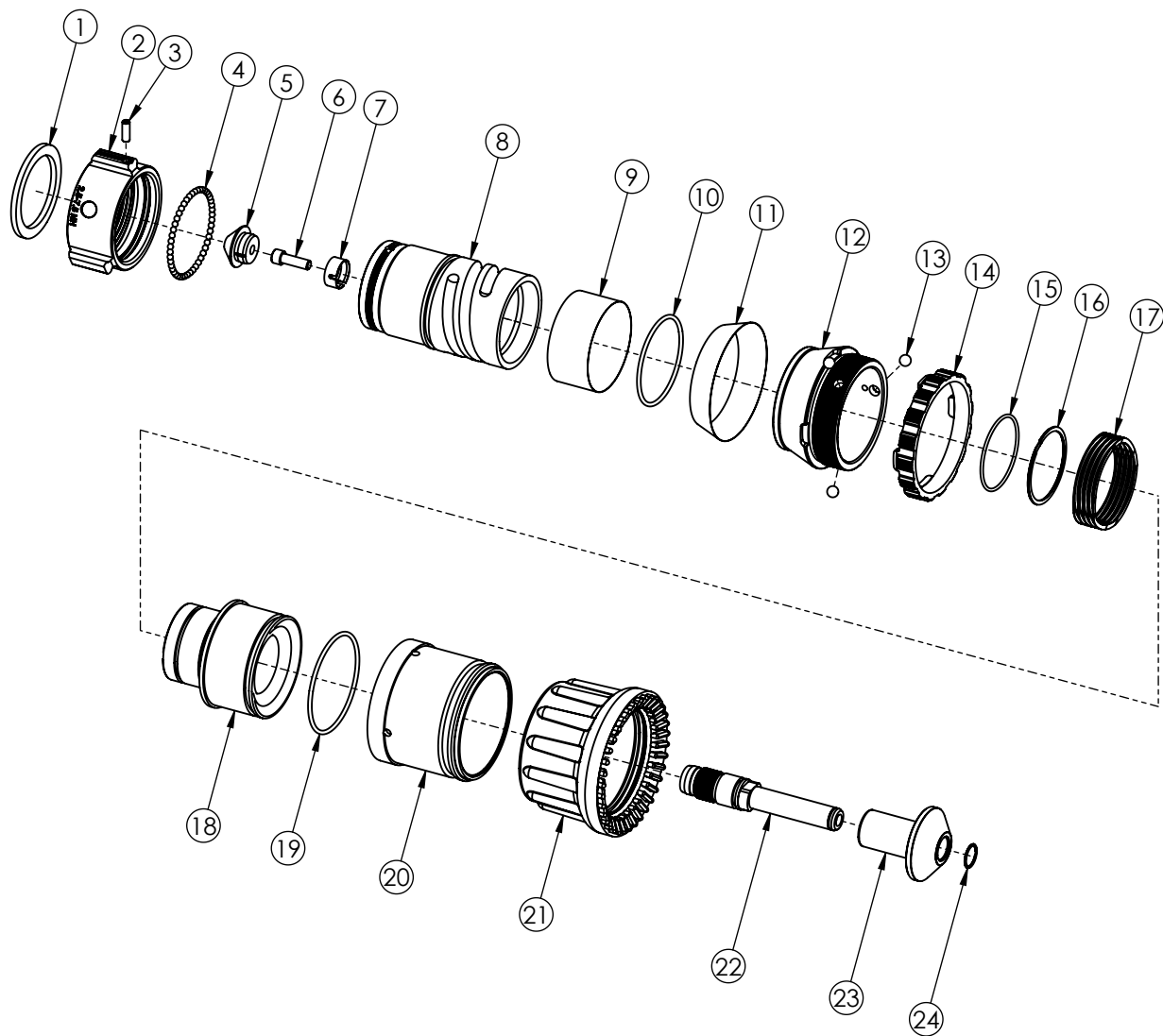

LXM-012

PARTS LIST: MAX-FLOW TIP FIXED GALLONAGE  
SERVICE AND MAINTENANCE

SHEET: 1 of 2  
REV: 0  
DATE: 4/6/21



TASK FORCE TIPS, LLC.  
3701 INNOVATION WAY  
VALPARAISO, IN 46383 USA  
(219)462-6161

A  
B  
C  
D  
E  
F  
G  
H

ITEM NO.	PART NUMBER	DESCRIPTION	
1	V3190	GASKET - 2.5" HOSE COUPLING	1
2	M307*	COUPLING 2.5"F	1
3	VT25-28SS750	1/4-28 X 3/4 SOCKET SET SCREW CUP POINT	1
4	V2120	3/16" STAINLESS BALL	48
5	MD591	TIP ONLY PLUG	1
6	VT31-18SH1.0	5/16-18 X 1 SOCKET HEAD CAP SCREW	1
7	MD571	LOCKING SLEEVE	1
8	MD545	FIN CAN/BARREL	1
9	MD74*	BARREL LABEL	1
10	VO-233	O-RING 233	1
11	MD7**	NAME LABEL	1
12	MD510	SHAPER GUIDE	1
13	VB375TO	3/8" TORLON BALL	3
14	MD513	SPACER RING	1
15	VO-143	O-RING 143	1
16	VR4240	SMALLEY RING	1
17	MD785	FLUSH WAVE SPRING	1
18	MD520	BARREL CONE	1
19	VO-236	O-RING 236	1
20	MD500	SHAPER	1
21	Z700	BUMPER	1
22	MD570	SHAFT	1
23	MD56*	BAFFLE FIXED GALLONAGE	1
24	VR4245	SMALLEY RING	1

LXM-012

PARTS LIST: MAX-FLOW TIP FIXED GALLONAGE  
SERVICE AND MAINTENANCE

SHEET: 2 of 2  
REV: 0  
DATE: 4/6/21



TASK FORCE TIPS, LLC.  
3701 INNOVATION WAY  
VALPARAISO, IN 46383 USA  
(219)462-6161