

# Maintenance Sheet

## Basic Lube Points For: H-VO

All Task Force Tips' nozzles are factory lubricated with high quality silicone grease. This lubricant has excellent wash out resistance and long term performance in firefighting nozzles. If your department has unusually hard or sandy water, the moving parts of the nozzle may be affected. Foam agents and water additives contain soaps and chemicals that may break down the factory lubrication.

The moving parts of the nozzle should be checked on a regular basis for smooth and free operation, and for signs of damage. IF THE NOZZLE IS OPERATING CORRECTLY, THEN NO ADDITIONAL LUBRICANT IS NEEDED. Any nozzle that is not operating correctly should be immediately removed from service.

The field use of Break Free CLP (aerosol or pump) lubricant will help to restore the smooth and free operation of the nozzle. However, these lubricants do not have the washout resistance and long-term performance of the silicone grease. Therefore, re-application of Break Free CLP will be needed on a regular basis. CAUTION: Aerosol lubricants contain solvents that can swell O-Rings if applied in excess. The swelling can inhibit smooth operation of the moving parts. When used in moderation, as directed, the solvents quickly evaporate without adversely swelling the O-Rings.

The nozzle can be returned to the factory for a complete checkup and re-lubrication with silicone grease.

### PART ONE — COUPLING DOWN

Position the nozzle at a 45° angle with the COUPLING end down. Then spray a short burst into these areas:

#### #1 DETENTS IN THE HANDLE

- Spray a small amount on the detent followers located in the handle on each side of the valve (between handle and valve body).
- Cycle the valve handle several times.
- Wipe off excess lubricant.

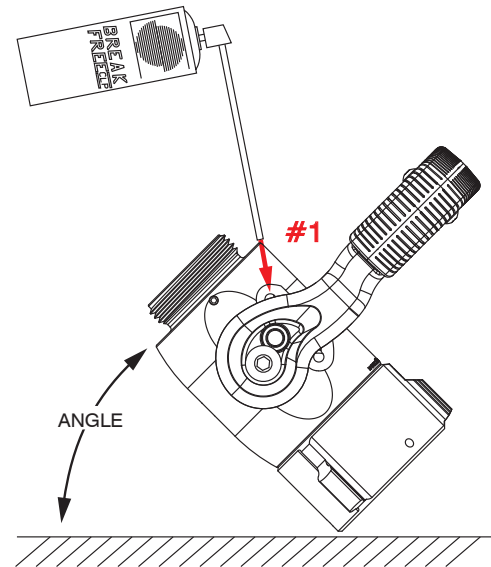

### PART TWO — COUPLING UP

Position the nozzle at a 45° angle with the COUPLING and BAIL end down. Then spray a short burst in these areas:

#### #2 TRUNIONS

- Spray a small amount on the trunnions (between the handle and the valve body).
- Cycle the valve handle several times.
- Wipe off excess lubricant.

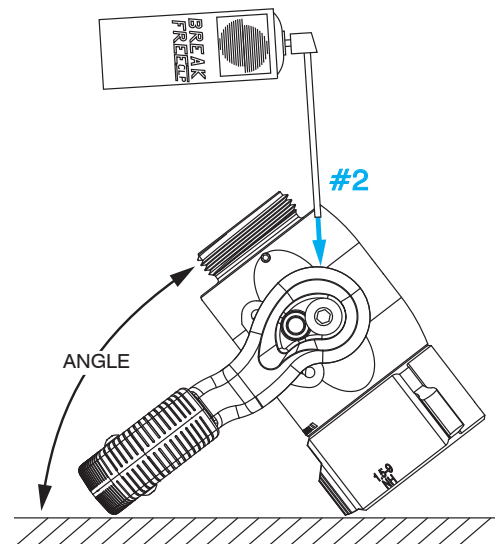

**IF THIS PROCEDURE DOES NOT RESTORE SMOOTH AND FREE OPERATION OF ALL THE MOVING PARTS, THEN FACTORY SERVICE IS NEEDED. • 24-HOUR HOT LINE — 800-348-2686 • tft.com**