



MANUAL: ThunderFog, QuadraFog and QuadraCup

INSTRUCTIONS FOR INSTALLATION, SAFE OPERATION AND MAINTENANCE

⚠ WARNING

Understand manual before use. Operation of this device without understanding the manual and receiving proper training is a misuse of this equipment. Obtain safety information at tft.com/serial-number

This instruction manual is intended to familiarize firefighters and maintenance personnel with the operation, servicing and safety procedures associated with the ThunderFog, QuadraFog and QuadraCup fire fighting nozzles.

This manual should be kept available to all operating and maintenance personnel.

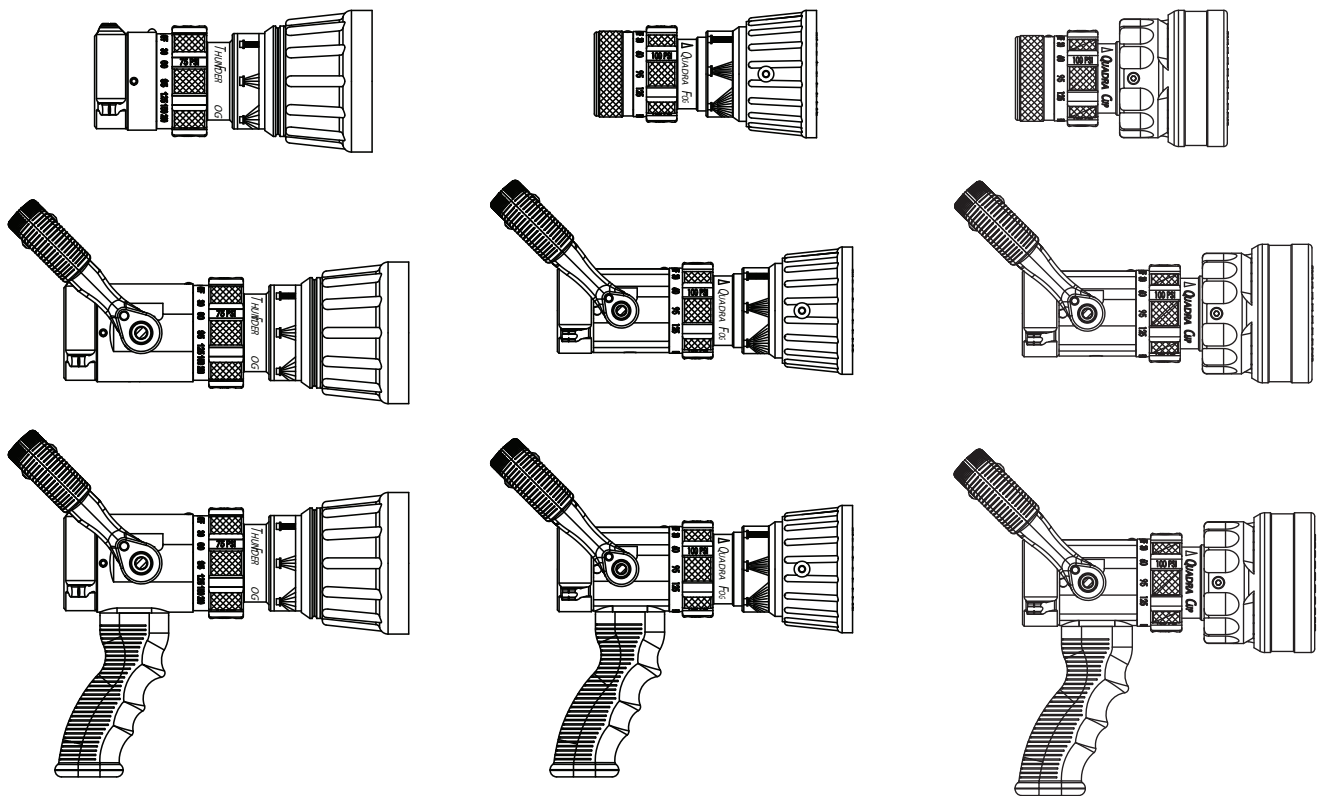

ThunderFog Series

QuadraFog Series

QuadraCup Series



PERSONAL RESPONSIBILITY CODE

The member companies of FEMSA that provide emergency response equipment and services want responders to know and understand the following:

1. Firefighting and Emergency Response are inherently dangerous activities requiring proper training in their hazards and the use of extreme caution at all times.
2. It is your responsibility to read and understand any user's instructions, including purpose and limitations, provided with any piece of equipment you may be called upon to use.
3. It is your responsibility to know that you have been properly trained in Firefighting and /or Emergency Response and in the use, precautions, and care of any equipment you may be called upon to use.
4. It is your responsibility to be in proper physical condition and to maintain the personal skill level required to operate any equipment you may be called upon to use.
5. It is your responsibility to know that your equipment is in operable condition and has been maintained in accordance with the manufacturer's instructions.
6. Failure to follow these guidelines may result in death, burns or other severe injury.



Fire and Emergency Manufacturers and Service Association
P.O. Box 147, Lynnfield, MA 01940 • www.FEMSA.org

Table Of Contents

- 1.0 MEANING OF SAFETY SIGNAL WORDS
- 2.0 SAFETY
- 3.0 GENERAL INFORMATION
 - 3.1 VARIOUS MODELS AND TERMS
 - 3.2 SPECIFICATIONS
 - 3.2.1 MECHANICAL
 - 3.3 NOZZLE COUPLINGS
 - 3.4 USE WITH SALT WATER
- 4.0 FLOW CHARACTERISTICS
- 5.0 NOZZLE CONTROLS
 - 5.1 BALL VALVE SHUTOFF
 - 5.2 SELECTOR RING
 - 5.2.1 FLOW SETTING
 - 5.2.2 FLUSH SETTING
 - 5.2.3 SHUTOFF SETTING (TIP ONLY MODELS)
 - 5.3 PATTERN CONTROL
 - 5.4 QUADRACUP NOZZLES
- 6.0 USE WITH FOAM
 - 6.1 FOAM ASPIRATING ATTACHMENTS
- 7.0 USE OF NOZZLES
- 8.0 APPROVALS
- 9.0 COLOR CODED VALVE HANDLE AND PISTOL GRIP
- 10.0 DRAWINGS AND PART LISTS
 - 10.1 1" QUADRAFOG SERIES DQ40, DQS40 & DQS40P
 - 10.2 1.5" QUADRAFOG AND QUADRACUP SERIES
 - 10.3 1.5" & 2.5" THUNDERFOG SERIES
- 11.0 WARRANTY
- 12.0 MAINTENANCE
 - 12.1 FIELD LUBRICATION
 - 12.2 SERVICE TESTING
 - 12.2.1 HYDROSTATIC TESTING
 - 12.2.2 FLOW TESTING
 - 12.2.3 RECORDS
 - 12.3 REPAIR
- 13.0 OPERATION and INSPECTION CHECKLIST

1.0 MEANING OF SAFETY SIGNAL WORDS

A safety related message is identified by a safety alert symbol and a signal word to indicate the level of risk involved with a particular hazard. Per ANSI standard Z535.6-2011, the definitions of the four signal words are as follows:



DANGER indicates a hazardous situation which, if not avoided, will result in death or serious injury.



WARNING indicates a hazardous situation which, if not avoided, could result in death or serious injury.



CAUTION indicates a potentially hazardous situation which, if not avoided, could result in minor or moderate injury.



NOTICE is used to address practices not related to physical injury.

2.0 SAFETY



An inadequate supply of nozzle pressure and/or flow will cause an ineffective stream and can result in injury, death, or loss of property. See flow graphs or call 800-348-2686 for assistance.



The nozzle may be damaged if frozen while containing significant amounts of water. Such damage may be difficult to detect visually and can lead to possible injury or death. Any time the nozzle is subject to possible damage due to freezing, it must be tested by qualified personnel before being considered safe for use.



This equipment is intended for use by trained personnel for firefighting. Their use for other purposes may involve hazards not addressed by this manual. Seek appropriate guidance and training to reduce risk of injury.



Failure to restrain nozzle reaction can cause firefighter injury from loss of footing and/or stream protection. Nozzle reaction will vary as supply conditions change: such as opening or closing other nozzles, hose line kinks, changes in pump settings, etc. Changes in spray pattern or flushing will also affect nozzle reaction. The nozzle operator must always be prepared in the event of these changes.



If nozzle gets out of control or away from operator, retreat from nozzle immediately. Do not attempt to regain control of nozzle while flowing water. Injury from whipping can occur.



Water is a conductor of electricity. Application of water on high voltage equipment can cause injury or death by electrocution. The amount of current that may be carried back to the nozzle will depend on the following factors:

- Voltage of the line or equipment
- Distance from the nozzle to the line or equipment
- Size of the stream
- Whether the stream is solid or broken
- Purity of the water (As Stated in The Fire Fighter and Electrical Equipment, The University of Michigan Extension Service, Fourth Printing 1983. Page 47)



Fire streams are capable of injury and damage. Do not direct water stream to cause injury or damage to persons or property.

3.0 GENERAL INFORMATION

This manual describes nozzles calibrated at 100 psi (7 bar) and 75 psi (5 bar). Contact factory for data specific to models that operate with metric flow calibrations. Thunderfog, Quadrafog and QuadraCup are economical, lightweight, and dependable nozzles. Their rugged construction is compatible with the use of fresh as well as firefighting foam solutions. Other important operating features are:

- Quick-acting pattern control from straight stream to wide fog
- Fixed fog teeth
- Stainless Steel spinning fog teeth available on some models
- Easily flushable while flowing to clear trapped debris
- Quick-change rear valve seat
- TFT's five-year warranty and unsurpassed customer service

3.1 VARIOUS MODELS AND TERMS

The nozzle is available in several different models and inlet connections. Basic body styles are shown in figure 1.

Selectable Flow: A nozzle with a discharge orifice that can be set to a user selected position. In each position the nozzle acts as a fixed orifice nozzle.

Fixed Flow: A nozzle with a discharge orifice that is a fixed opening size. The user can set the opening to flush positions, or on tip only models to the OFF position.

Tip Only: a nozzle without an integral ball shutoff valve. Thunderfog, Quadrafog and QuadraCup nozzles are available in a variety of flow ranges and configurations. All models deliver the selected flow when the rated pressure is supplied to the nozzle. Flow settings and recommended hose sizes are:

SERIES	RECOMMENDED HOSE SIZE		FLOW SETTINGS @100 PSI (7bar)		NOZZLE TYPE
	INCHES	MM	GPM	l/min	
1" QUADRAFOG	3/4, 1	19, 25	5, 10, 24, 40	20, 40, 100, 150	Selectable Flow
1.5" QUADRAFOG	1-1/2	38	30, 60, 95, 125	115, 230, 360, 475	Selectable Flow
1.5" QUADRACUP	1-1/2	38	30, 60, 95, 125	115, 230, 360, 475	Selectable Flow, Foam
1.5" THUNDERFOG	1-1/2 to 1-3/4	38 to 45	30, 60, 95, 125, 150, 200	115, 230, 360, 475, 550, 750	Selectable Flow
2.5" THUNDERFOG	1-1/2 to 2-1/2	38 to 64	95, 125, 150, 200, 250	360, 475, 550, 750, 950	Selectable Flow

* Other threads, coupling sizes, or connector styles can be specified at time of order.

ThunderFog, QuadraFog and QuadraCup nozzles are available in several models. Some common models are shown in figure 1.

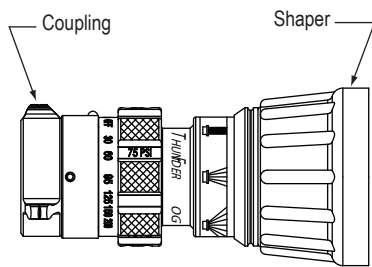

A) TIP ONLY
(not available with 2-1/2" coupling)

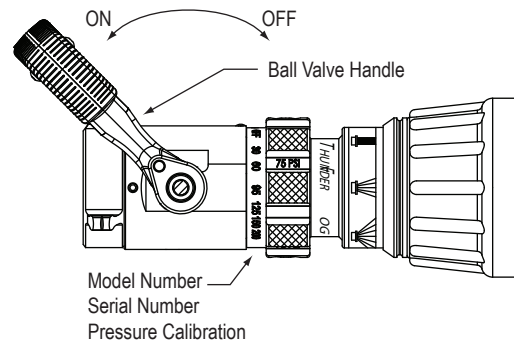

B) BALL VALVE

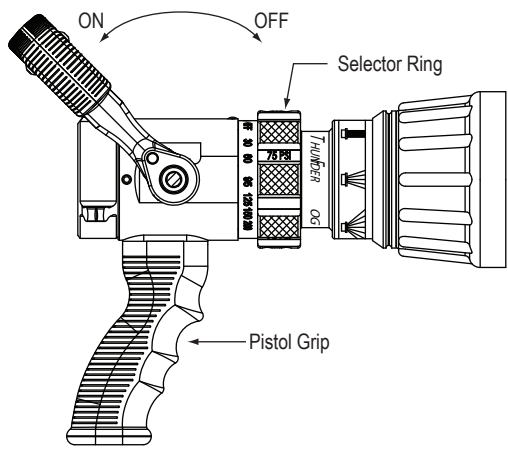

C) BALL VALVE WITH PISTOL GRIP

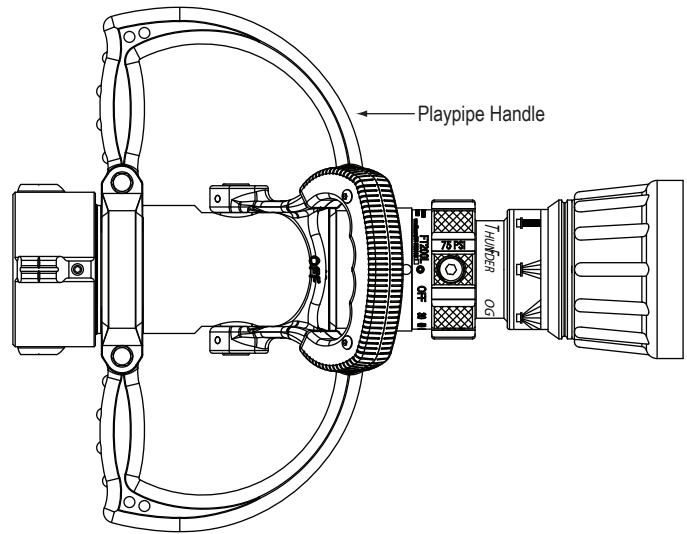

D) PLAYPIPE

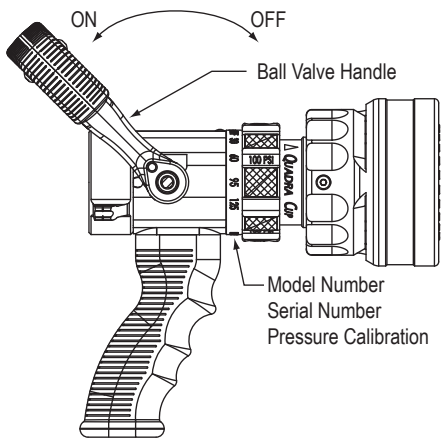

E) QUADRACUP RETRACTED POSITION

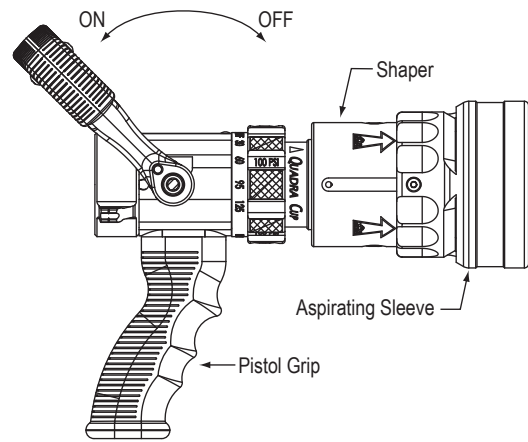

F) QUADRACUP EXTENDED POSITION

FIGURE 1
BASIC NOZZLE CONFIGURATIONS AND TERMS

3.2 SPECIFICATIONS

3.2.1 MECHANICAL

Maximum nozzle inlet pressure with valve shutoff	1" Quadrafog 300 psi Standard Model	21 bar
	1" Quadrafog 800 psi High Pressure Model	55 bar
	1.5" Quadrafog & Quadracup 300 psi	21 bar
	1.5" & 2.5" Thunderfog 300 psi	21 bar
Operating temperature range of fluid	33 to 120 F	1 to 50 C
Storage temperature range of fluid	-40 to 150 F	-40 to 65 C
Materials used	Aluminum 6000 series hard anodized MIL 8625 class 3 type 2, stainless steel 300 series, nylon 6-6, nitrile rubber	

3.3 NOZZLE COUPLING

Many inlet couplings such as NH (National Hose) or NPSH (National Pipe Straight Hose) can be specified at time of order.



Nozzle must be mated to a hose line with matched threads. Mismatched or damaged threads may cause nozzle to leak or uncouple under pressure and could cause injury.



Dissimilar metals coupled together can cause galvanic corrosion that can result in the inability to unscrew the threads or complete loss of thread engagement over time. Per NFPA 1962, if dissimilar metals are left coupled together an anti-corrosive lubricant should be applied to the threads. Also the coupling should be disconnected and inspected at least quarterly.

3.4 USE WITH SALT WATER

Use with saltwater is permissible provided nozzle is thoroughly cleaned with fresh water after each use. The service life of the nozzle may be shortened due to the effects of corrosion and is not covered under warranty.

4.0 FLOW CHARACTERISTICS

At each flow setting the nozzle is set to a predetermined fixed orifice. Relationship of flow and nozzle pressure at each setting is shown in figure 2. Contact the factory or visit the website (tft.com) for range and trajectory data.

SPECIAL CONFIGURATIONS If nozzles are made according to the special marking or performance requirements of the fire department then the operating characteristics may differ from the published data in this manual. Repair parts specific to each serial number may differ from those shown in the service procedure. The required parts for each serial number are available on-line by entering tft.123456 with the numbers corresponding to the serial number engraved on the product.

The charts in this document give specific examples of pump pressure and flow for various hoses and lengths. Losses may vary due to differences in hose construction resulting in flows different than shown. For situations or lengths of hose not listed on the chart, approximate flows can be calculated using conventional hydraulics.

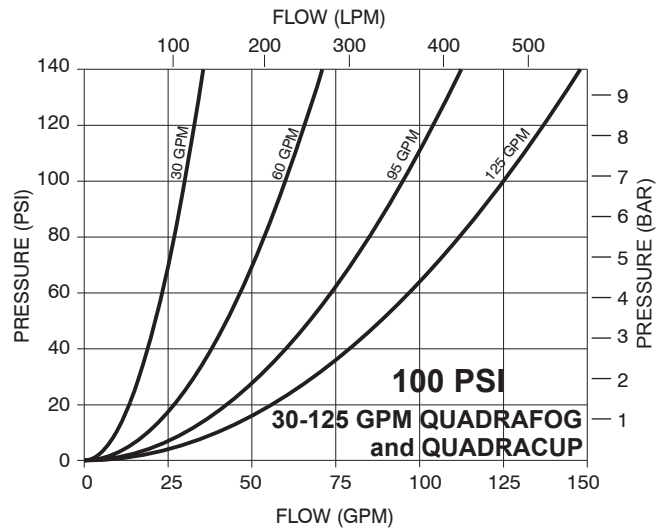
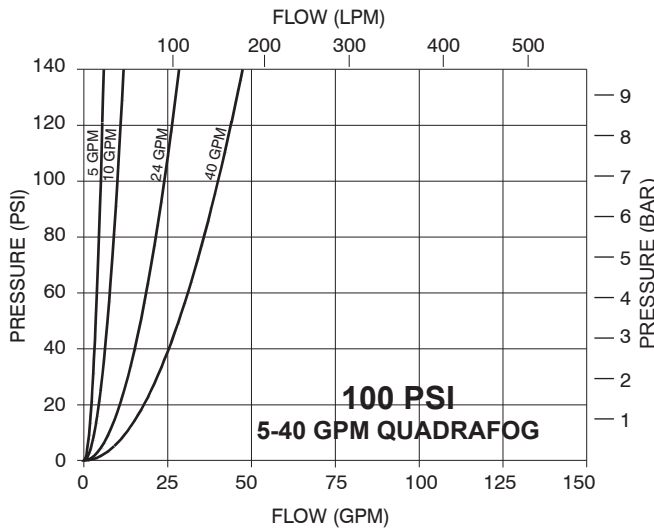

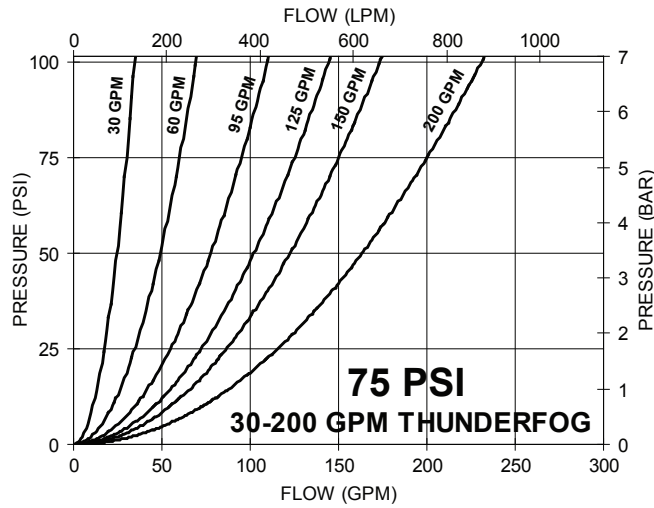
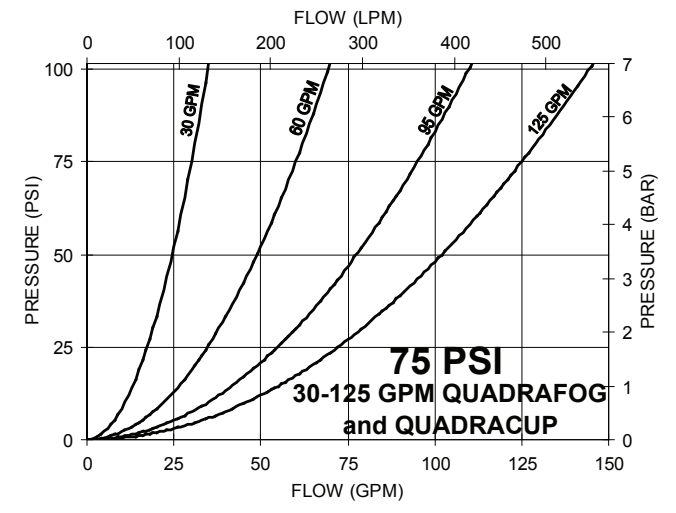
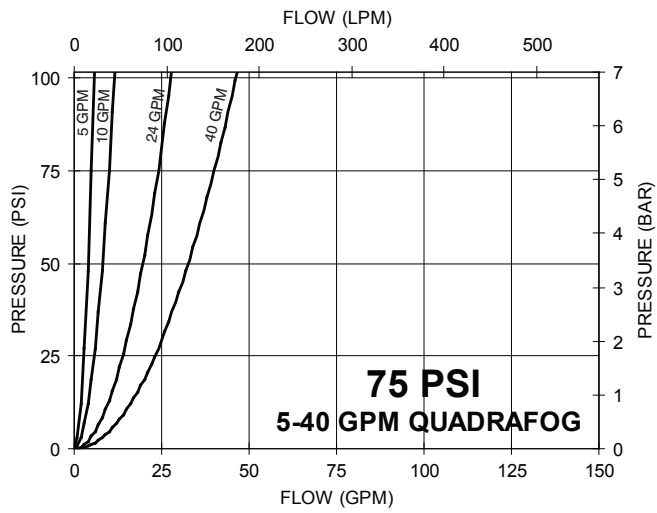
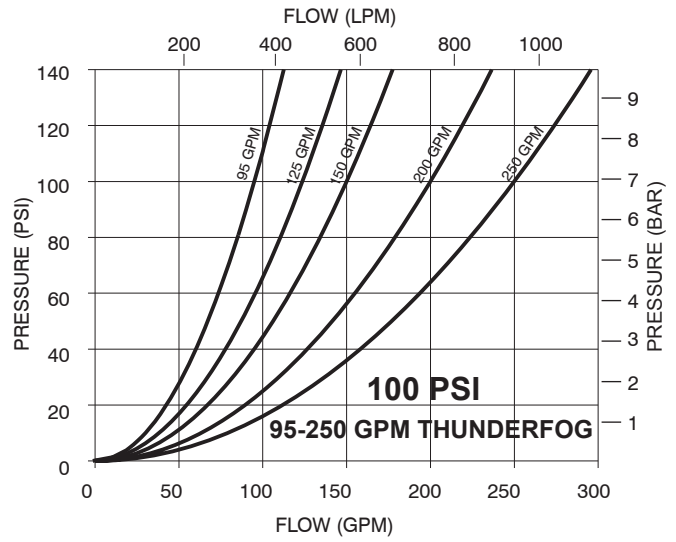
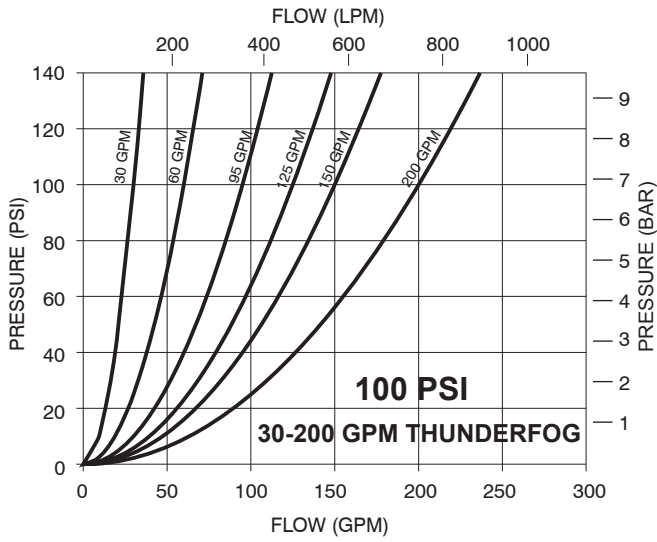

FIGURE 2 NOZZLE FLOW CHARACTERISTICS

5.0 NOZZLE CONTROLS

5.1 BALL VALVE SHUTOFF

Models with a ball valve are shut off when the valve handle is fully forward. Pulling back on the handle opens the valve. Open valve slowly to avoid sudden changes in nozzle reaction. Close valve slowly to prevent water hammer. Note: In partially open positions a ball valve will cause turbulence and adversely affect stream quality. Nozzles attached to an in-service hose shall be stored in the off position.

5.2 SELECTOR RING

5.2.1 FLOW SETTING

The selector ring is marked with various flow settings. Turn the selector ring so the desired setting lines up with the silver indicator pin. A spring-loaded detent is provided at each flow setting. The nozzle will flow the indicated amount when the pressure at the nozzle is 100 PSI (7 bar) or 75 PSI (5 bar) on low pressure versions.

5.2.2 FLUSH SETTING

Debris may become trapped in the nozzle causing poor stream quality, shortened reach and reduced flow. To remove trapped debris, the nozzle can be flushed as follows: While still flowing water, rotate the selector ring into the flush position. This will open up the nozzle, allowing debris to pass through. Rotate the selector ring out of flush to continue normal operations. The nozzle operator must be prepared for a change in nozzle reaction when returning the nozzle from the flush position to retain control of the nozzle.

⚠ WARNING Large amounts or pieces of debris may be unflushable and can reduce the flow of the nozzle resulting in an ineffective flow. In the event of a blockage, it may be necessary to retreat to a safe area, uncouple the nozzle and remove debris.

5.2.3 SHUTOFF SETTING (TIP-ONLY MODELS)

On tip-only models the selector ring has a shutoff setting to stop the nozzle flow. To shut off the nozzle, rotate the selector ring clockwise (as seen from the operating position behind the nozzle) into the "OFF" position. Rotate counterclockwise into a flow setting to open nozzle.

5.3 PATTERN CONTROL

The Thunderfog, Quadrafog and QuadraCup nozzles have full pattern control from straight stream to wide fog. Turning the SHAPER clockwise (as seen from the operating position behind the nozzle) moves the SHAPER to the straight stream position. Turning the SHAPER counterclockwise will result in an increasingly wider pattern.

Since the stream trim point varies with the flow, the stream should be 'trimmed' after changing the flow to obtain the straightest and furthest reaching stream. The nozzle reaction is greatest when the shaper is in the straight-stream position.

To properly trim a stream, first open the pattern to a narrow fog. Then close the stream to parallel to give maximum reach. NOTE: Turning the shaper further forward will cause stream crossover and reduce the effective reach of the nozzle.

The nozzle operator must be prepared for a change in reaction as the pattern is changed.

5.4 QUADRACUP NOZZLES

The QuadraCup nozzle is capable of producing aspirated foam as well as a conventional straight stream and wide protective fog pattern. The QuadraCup functions just like the QuadraFog nozzle when the aspirating sleeve is in the retracted position as in figure 1E.

To use the aspirating feature of the QuadraCup, the nozzle operator need only slide the aspirating sleeve portion of the nozzle forward as in figure 1F. Rotation of the shaper when the sleeve is extended will provide the nozzle operator control of reach and aspiration. If an immediate wide protective fog pattern is needed, the sleeve can be retracted instantly to its regular position..

6.0 USE WITH FOAM

The nozzle may be used with foam solutions. Refer to fire service training for the proper use of foam.

⚠ WARNING

For Class B fires, lack of foam or interruption in the foam stream can cause a break in the foam blanket and greatly increase the risk of injury or death.

Assure that:

- Application rate is sufficient (see NFPA 11 or foam manufacturer's recommendations)
- Enough concentrate is on hand to complete task (see NFPA for minimum duration time requirements)
- Foam logistics have been carefully planned.

Allow for such things as:

- Storage of foam in a location not exposed to the hazard it protects
- Personnel, equipment and technique to deliver foam at a rapid enough rate
- Removal of empty foam containers
- Clear path to deliver foam, as hoses and other equipment and vehicles are deployed

⚠ WARNING

Improper use of foam can result in injury or damage to the environment. Follow foam manufacturer's instructions and fire service training to avoid:

- Using wrong type of foam on a fire, i.e. Class A foam on a Class B fire
- Plunging foam into pools of burning liquid fuels
- Causing environmental damage
- Directing stream at personnel

⚠ WARNING

There are a wide variety of foam concentrates. Each user is responsible for verifying that any foam concentrate chosen to be used with this unit has been tested to assure that the foam obtained is suitable for the purpose intended.

⚠ WARNING

Use of compressed air foam (CAF) with hand held nozzles can cause sudden surges in nozzle reaction force resulting in risk of injury or death from loss of footing or hose whipping. Be prepared for sudden changes in nozzle reaction caused by:

- Slug loading (Loss of foam concentrate sends slugs of air and water into the nozzle)
- Sudden release of built-up pressure in the hose when opening a nozzle

6.1 FOAM ASPIRATING ATTACHMENTS

Multi-expansion or low expansion aspirating attachments may be used with nozzles to increase the expansion ratio. These foam tubes attach and detach quickly from the nozzle. As expansion ratio is increased, the reach of the nozzle will be decreased due to the greater amount of bubbles in the stream and their ability to penetrate the air. Generally the straight stream reach with foam is approximately 10% less than with water only. Actual results will vary based on brand of foam, hardness of water, temperature, etc. For specific information, see LIA-025 (MANUAL: Foam Attachments for TFT Nozzles).

7.0 USE OF NOZZLES

Many factors contribute to the extinguishment of a fire. Among the most important is delivering water at a flow rate sufficient to absorb heat faster than it is being generated. The flow rate depends largely on the pump discharge pressure and hose friction loss. It can be calculated using a hydraulic equation such as:

PDP = Pump discharge pressure in PSI

NP = Nozzle pressure in PSI

PDP = NP+FL+DL+EL FL = Hose friction loss in PSI

DL = Device loss in PSI

EL = Elevation loss in PSI

This manual is not intended to act as a training guide for safe fireground tactics and operations.

For additional information visit tft.com or contact customer service at 800-348-2686.

8.0 APPROVALS

Many nozzle configurations carry the FM Approval rating, NFPA certification, or EN certification.

9.0 COLOR CODED VALVE HANDLE AND PISTOL GRIP

The TFT ULTIMATIC, MID-MATIC & HANDLINE with lever type valve handles are supplied with black valve handle covers and pistol grips. The handle covers and pistol grips are available from TFT in various colors for those departments wishing to color code the nozzle to the discharge controls. A colored handle cover set will be sent upon receipt of the warranty card by TFT. Your department's name can also be engraved on the covers (see warranty card for more information).

Handle covers are replaceable by removing the four screws that hold the handle covers in place. Use a 3/32" allen wrench when replacing screws. Pistol grip is replaceable by following TFT instruction sheet LTT-108.

For standardization NFPA 1901 (A-4-9.3) recommends the following color code scheme:

Preconnect #1 or Bumper Jump Line	Orange	Other Colors Available:
Preconnect or discharge #2	Red	• Gray
Preconnect or discharge #3	Yellow	• Pink
Preconnect or discharge #4	White	• Purple
Preconnect or discharge #5	Blue	• Tan
Preconnect or discharge #6	Black	
Preconnect or discharge #7	Green	
Foam Lines	Red w/ White border (Red/White)	

10.0 DRAWINGS AND PART LISTS

10.1 1" QUADRAFOG SERIES DQ40, DQS40 & DQS40P

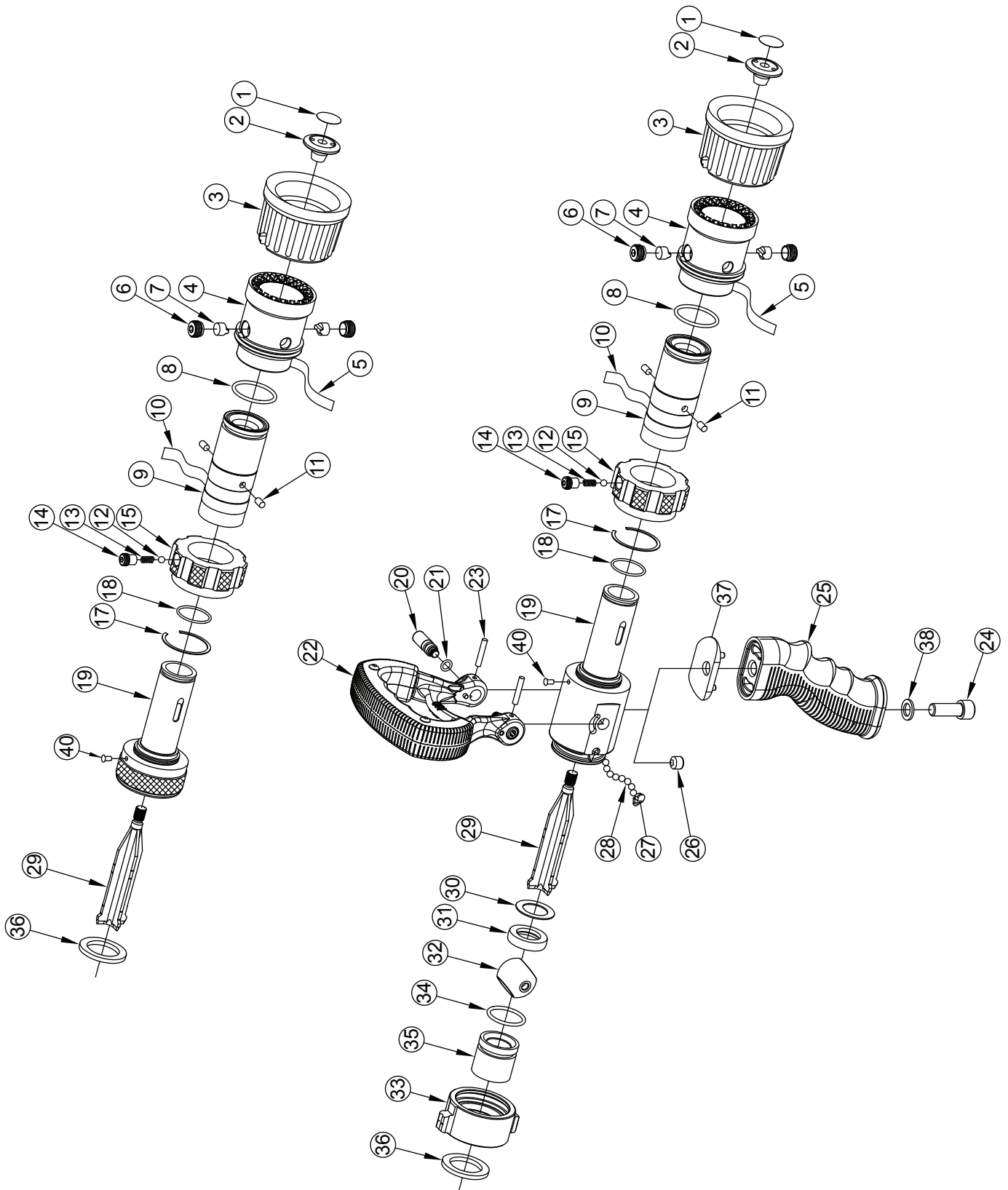

Ref #	Description	Qty	Order #
1	DQ Deflector Label	1	DL10
2	DQ Deflector	1	DQ210
3	DQ Bumper	1	DQ275
4	Head	1	DQ220
5	DQ Pattern Label	1	DL200
6	Cup	2	DQ260
7	V Follower	2	DQ265
8	O-Ring 123	1	VO-123
9*	Gallonage Sleeve DQ	1	DQ240
			DQ241
10	Name Label	1	DL241
11	DQ Key Pins	2	DQ250
12	3/16" Torlon Ball	1	V2120-Torlon
13	Spring #C0180-032-0310-S	1	VM4195
14	Detent Screw	1	D290
15*	Index Ring	1	DQ230
			DQ231
17	VSL-149-S02 Smalley Ring	1	V4245
18	O-Ring 021	1	VO-021
19*	DQ Base	1	DQ201
			DQ205**
20	Trunnion	2	D07540
21	O-Ring 010	2	VO-010
22	DQ Handle Subassembly	1	DQ680
23	5/32 x 7/8 HDP Spirol Pin	2	V1900
24	3/8-16 x 7/8" Socket Head Cap Screw	1	VT37-16SH1.0
25	Pistol Grip Small R	1	HM692-BLK
26	3/8-16 x 5/16" Socket Set Screw	1	VT37-16SS312
27	Port Plug	1	B770
28	3/16" SS Ball 302	26	V2120
29	Stem	1	DQ280
30	Belleville Washer	1	D07590
31	75 Front Seat	1	D07570
32	75 Ball	1	D07530
33**	75 Coupling	1	D07597**
34	O-Ring 120	1	VO-120
35	75 Rear Seat	1	D07580
36	1.0" Coupling Gasket	1	V3040
37	Spacer	1	HM693-D
38	Flat Washer	1	VM4901
39	Stop Pin	2	D07550
40	6 x 1/4 SS Drive Screw	1	VT06E00DS250

* - CONSULT FACTORY FOR SPECIFIC PART NUMBERS

** - STATE DESIRED THREAD WHEN ORDERING

10.2 1.5" QUADRAFOG AND QUADRACUP SERIES

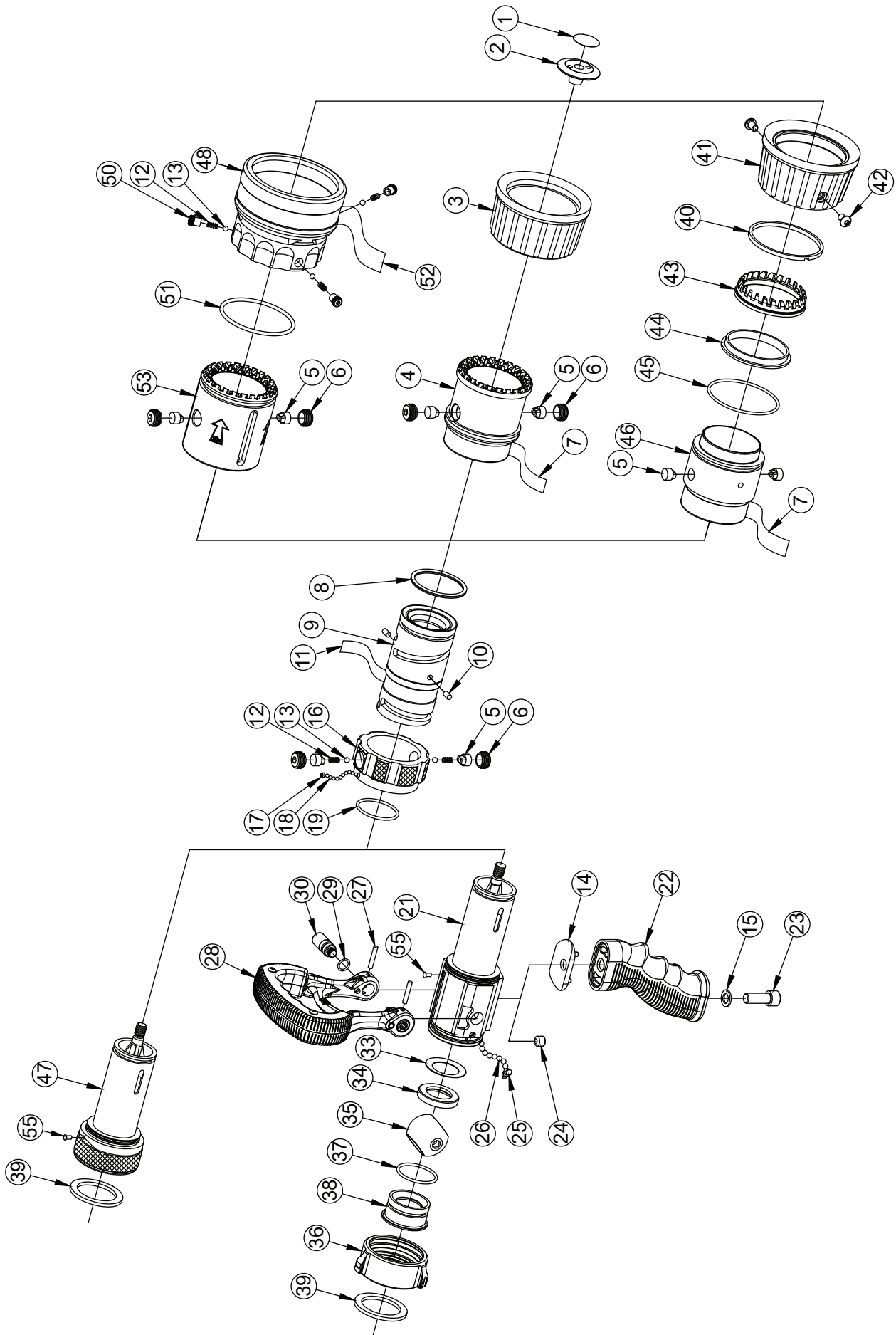

Ref #	Description	Qty	Order #
1	Deflector Label	1	FL10
2	Deflector	1	FT210
3	Bumper	1	FT270
4	Head	1	FT220
5	'V' Follower	2	JT263
6	Cup	2	FT260
7	Pattern Label	1	FL200
8	Quad Ring	1	VOQ-4225
9	Gallorage Sleeve	1	FT240
			FT241*
10	Key Pins	2	FT252
11	Name Label	1	FL241
12	Helical Spring	3	VM4195
13	3/16" Torton Ball	3	V2120-TORLON
14	Pistol Grip Spacer	1	HM693-F
15	3/8" Flat Washer	1	VM4901
16	Index Ring	1	FT230
			FT231*
17	8-32 x 1/8" Set Screw	1	VT08-32SS125
18	1/8" Acetal Ball	50	VB125AC
19	O-Ring	1	VO-127
21	Quadrafog Base	1	FT202
22	Pistol Grip	1	HM692-BLK
23	Socket Head Screw	1	VT37-16SH1.0
24	Set Screw	1	VT37-16SS312
25	Port Plug	1	B770
26	Stainless Steel Balls	34	V2120

Ref #	Description	Qty	Order #
27	Spirol Pin	2	V1900
28	FQ Handle Subassembly	1	FQ860
29	O-Ring	2	VO-012
30	Trunnion	2	F10040
31	Stop Pin	2	F10050
33	Bellville Washer	1	F10090
34	Front Seat	1	F10071
35	Ball	1	F10030
36	Coupling	1	F10097
37	O-Ring	1	VO-126
38	Rear Seat	1	F10080
39	Gasket	1	V3130
40	O.D. Wear Ring	1	FT267
41	Spinning Tooth Bumper	1	FT265
42	1/4"-20 x 3/8 Button Head Screw	2	VT25R20BH375
43	Spinning Teeth	1	FT222
44	I.D. Wear Ring	1	FT227
45	O-Ring	1	VO-145
46	Spinning Teeth Head	1	FT225
47	FQ Base Kit	1	FQ805
48	Cup	1	F675
50	Detent Screw	3	D290
51	O-Ring	1	VO-231
52	Pattern Label QuadraCup	1	FL205
53	Foam Head	1	FT226
55	6 x 1/4 SS Drive Screw	1	VT06E00DS250

* - CONSULT FACTORY FOR SPECIFIC PART NUMBERS

** - STATE DESIRED THREAD WHEN ORDERING

10.3 1.5" & 2.5" THUNDERFOG SERIES

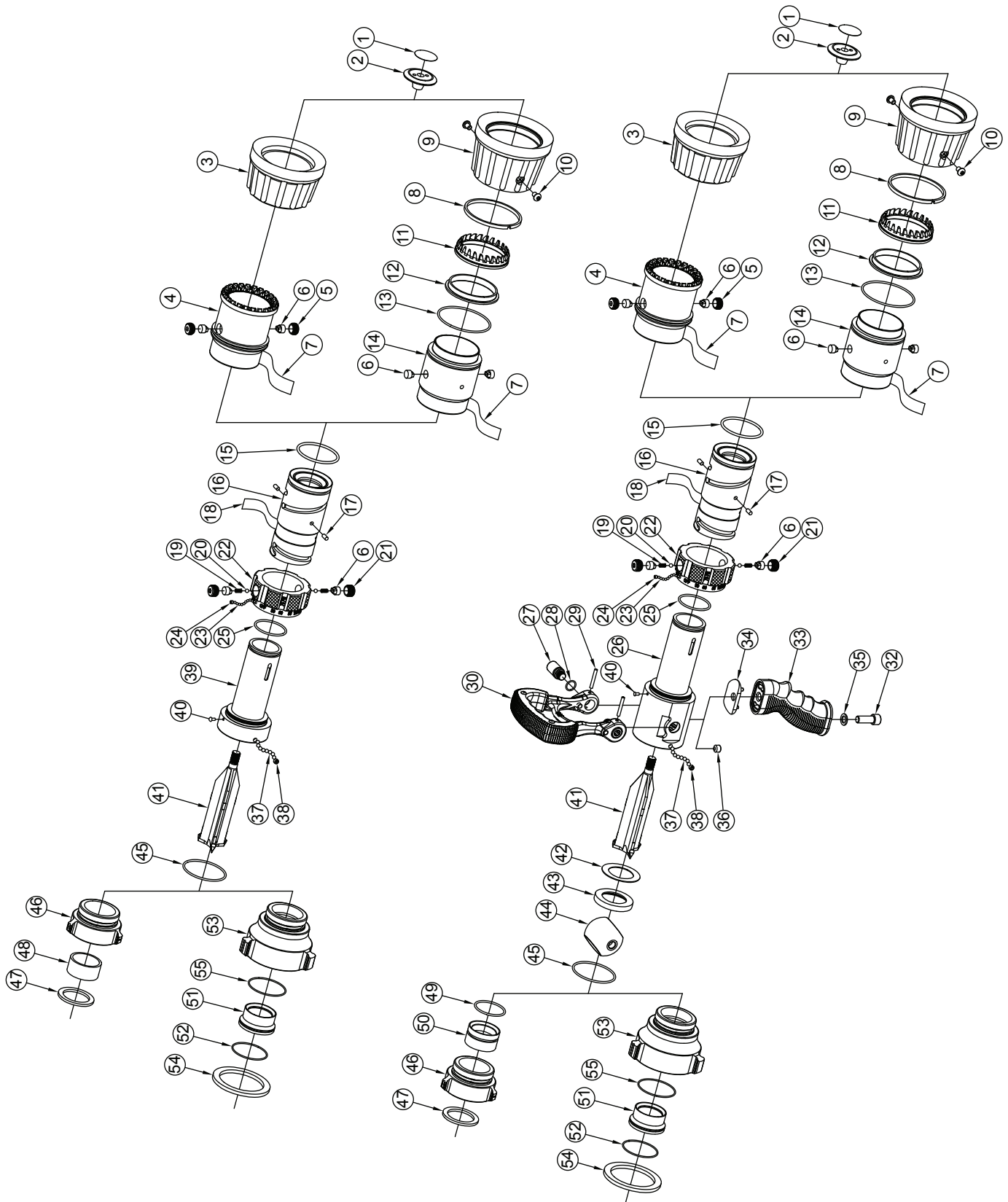

Ref #	Description	Qty	Order #
1	Deflector Label	1	JL10
2	Deflector	1	JT210
3	Bumper	1	JT270
4	Fixed Head	1	JT220
5	Cup	2	FT260
6	V Follower	4	JT263
7*	Pattern Label	1	*
8	O.D. Wear Ring	1	JT267
9	Bumper (Spinning Teeth)	1	JT265
10	¼-20 x 3/8 Button Head Screw	1	VT25R20BH375
11	JT Spinning Teeth	1	JT222
12	ID Wear Ring	1	JT227
13	O-Ring 149	1	VO-149
14	Head (Spinning Teeth)	1	JT225
15	O-Ring 227	1	VO-227
16*	Gallorage Sleeve	1	*
17	Key Pins	2	JT250
18*	Name Label	1	*
19	Spring #C0180-032-0310	2	VM4195
20	3/16" Torlon Ball	2	V2120-TORLON
21	Cup	2	JT260
22*	Index Ring	1	*
23	1/8" Acetal Ball	54	VB125AC
24	#8-32 x 5/32 Socket Set Screw	1	VT08-32SS156
25	O-Ring 130	1	VO-130
26	JTS 250 Base	1	JT204
27	140 Trunnion	2	F14040
28	O-Ring 014	2	VO-014

Ref #	Description	Qty	Order #
29	5/32 x 1 1/8 HDP Spirol Pin	2	V1920
30	FT Handle Subassembly	1	FT860
31	140 Stop Pin	2	F14050
32	3/8-16 X 1 Socket Head Cap Screw	1	VT37-16SH1.0
33	Pistol Grip	1	HM692-BLK
34	F140 Grip Spacer	1	HM693-J
35	3/8" Flat Washer	1	VM4901
36	3/8-16 X 1 Socket Head Cap Screw	1	VT37-16SS312
37	3/16" SS Ball	36/38	V2120
38*	1/4-28 Socket Set Screw	1	VT25-28SS187* VT25-28SS250*
39	Universal JT Base	1	JT205
40	1/8X1/4 SS Button Head	1	VT12E00RI250
41	Stem	1	JT280
42	Belleville Washer	1	J14090
43	140 Front Seat	1	F14070
44	140 Ball	1	F14030
45	O-Ring - 140	1	VO-140
46**	1.5" Coupling	1	F14097**
47	1.5" Coupling Gasket	1	V3130
48	Backup Plate	1	JT275
49	O-Ring 129	1	VO-129
50	140 Rear Seat	1	F14080
51	140 2 ½" Rear Seat	1	J14080
52	O-Ring 033	1	VO-033
53**	2.5" Coupling	1	J14097**
54	2.5" Gasket	1	V3190
55	O-Ring 032	1	VO-032

* - CONSULT FACTORY FOR SPECIFIC PART NUMBERS
** - STATE DESIRED THREAD WHEN ORDERING

11.0 WARRANTY

Task Force Tips LLC, 3701 Innovation Way, Valparaiso, Indiana 46383-9327 USA (“TFT”) warrants to the original purchaser of its nozzles (“equipment”), and to anyone to whom it is transferred, that the equipment shall be free from defects in material and workmanship during the five (5) year period from the date of purchase.

TFT’s obligation under this warranty is specifically limited to replacing or repairing the equipment (or its parts) which are shown by TFT’s examination to be in a defective condition attributable to TFT. To qualify for this limited warranty, the claimant must return the equipment to TFT, at 3701 Innovation Way, Valparaiso, Indiana 46383-9327 USA, within a reasonable time after discovery of the defect. TFT will examine the equipment. If TFT determines that there is a defect attributable to it, TFT will correct the problem within a reasonable time. If the equipment is covered by this limited warranty, TFT will assume the expenses of repair.

If any defect attributable to TFT under this limited warranty cannot be reasonably cured by repair or replacement, TFT may elect to refund the purchase price of the equipment, less reasonable depreciation, in complete discharge of its obligations under this limited warranty. If TFT makes this election, claimant shall return the equipment to TFT free and clear of any liens and encumbrances.

This is a limited warranty. The original purchaser of the equipment, any person to whom it is transferred, and any person who is an intended or unintended beneficiary of the equipment, shall not be entitled to recover from TFT any consequential or incidental damages for injury to person and/or property resulting from any defective equipment manufactured or assembled by TFT. It is agreed and understood that the price stated for the equipment is in part consideration for limiting TFT’s liability. Some states do not allow the exclusion or limitation of incidental or consequential damages, so the above may not apply to you.

TFT shall have no obligation under this limited warranty if the equipment is, or has been, misused or neglected (including failure to provide reasonable maintenance) or if there have been accidents to the equipment or if it has been repaired or altered by someone else.

THIS IS A LIMITED EXPRESS WARRANTY ONLY. TFT EXPRESSLY DISCLAIMS WITH RESPECT TO THE EQUIPMENT ALL IMPLIED WARRANTIES OF MERCHANTABILITY AND ALL IMPLIED WARRANTIES OF FITNESS FOR A PARTICULAR PURPOSE. THERE IS NO WARRANTY OF ANY NATURE MADE BY TFT BEYOND THAT STATED IN THIS DOCUMENT.

This limited warranty gives you specific legal rights, and you may also have other rights which vary from state to state.

12.0 MAINTENANCE

TFT nozzles are designed and manufactured to be damage resistant and require minimal maintenance. However, as the primary firefighting tool upon which your life depends, it should be treated accordingly. Do not drop or throw equipment.

12.1 FIELD LUBRICATION

All Task Force Tip nozzles are factory lubricated with high quality silicone grease. This lubricant has excellent washout resistance and long term performance. If your department has unusually hard or sandy water, the moving parts may be affected. Foam agents and water additives contain soaps and chemicals that may break down the factory lubrication.

The moving parts of the nozzle should be checked on a regular basis for smooth and free operation, and signs of damage. **IF THE NOZZLE IS OPERATING CORRECTLY, THEN NO ADDITIONAL LUBRICATION IS NEEDED.** Any nozzle that is not operating correctly should be immediately removed from service.

12.2 SERVICE TESTING

In accordance with NFPA 1962 (2013), nozzles must be tested a minimum of annually. Nozzles failing any part of this test must be removed from service, repaired and retested upon completion of the repair.

12.2.1 HYDROSTATIC TESTING

Each nozzle with a shut off mechanism shall be tested in the following manner.

1. The nozzle shall be placed in a device capable of holding it and the shut off shall be closed.
2. A device capable of exerting a hydrostatic pressure of 300 psi (2070 kPa) or 1.5 times the maximum operating pressure, whichever is higher, shall be attached to the nozzle.
3. All air shall be bled from the system.
4. The gage pressure shall be increased by 50 psi (3.5 bar or 345 kPa) increments, held for 30 seconds at each pressure up to the maximum pressure for which the nozzle is being tested, and then held for one minute without leakage.
5. There shall be no sign of leakage through the valve or shut off.

12.2.2 FLOW TESTING

Flow testing must be conducted in the following manner.

1. The nozzle shall be mounted so that the flow rate and pressure through the nozzle and the pressure at the inlet can be accurately measured.
2. With the shut off fully open, the inlet pressure shall be adjusted to the rated pressure ± 2 percent.
3. The valve or shut off and pattern controls shall be operated through their full range of motion at 100 psi (6.9 bar or 690 kPa) with no signs of leaking, binding or other problems.
4. Evaluate the flow of nozzles as defined by NFPA 1964 in the following manner:

Basic Spray Nozzles shall flow no less than and no more than 10 percent over the rated flow at the rated pressure in the straight stream and wide-angle fog settings.

Constant and Selectable Gallonage Nozzles shall flow no less than and no more than 10 percent over the rated flow at the rated pressure at each predetermined flow selection.

NFPA 1962: Standard for the care, use, inspection, service testing, and replacement of fire hose, couplings, nozzles and fire hose appliances. (2013 ed., Section 5.3). Quincy, MA: National Fire Protection Agency.

12.2.3 RECORDS

A record of testing and repairs must be maintained from the time the nozzle is purchased until it is discarded. Each TFT nozzle is engraved with a unique serial number which, if so desired, can be used to identify nozzle for documentation purposes.

The following information, if applicable, must be included on the test record for each nozzle:

1. Assigned identification number
2. Manufacturer
3. Product or model designation
4. Vendor
5. Warranty
6. Hose connection size
7. Maximum operating pressure
8. Flow rate or range
9. Date received and date put in service
10. Date of each service test and service test results
11. Damage and repairs, including who made the repairs and the cost of repair parts
12. Reason removed from service

NFPA 1962: Standard for the care, use, inspection, service testing, and replacement of fire hose, couplings, nozzles and fire hose appliances. (2013 ed., Section 5.5.4). Quincy, MA: National Fire Protection Agency.

12.3 REPAIR

Factory service is available with repair time seldom exceeding one day in our facility. Factory-serviced nozzles are repaired by experienced technicians, wet tested to original specifications, and promptly returned. Repair charges for non-warranty items are minimal. Any returns should include a note as to the nature of the problem and whom to reach in case of questions.

Repair parts and service procedures are available for those wishing to perform their own repairs. Task Force Tips assumes no liability for damage to equipment or injury to personnel that is a result of user service. Contact the factory or visit the web site at tft.com for parts lists, exploded views, test procedures and troubleshooting guides



Any alterations to the nozzle and its markings could diminish safety and constitutes a misuse of this product.

13.0 OPERATION and INSPECTION CHECKLIST

Before each use the nozzle must be inspected to this checklist;

- 1) There is no damage to the appliance that could impair safe operation (e.g. dents, cracks, corrosion, missing, broken or loose parts, damaged markings, or other defects)
- 2) Debris screen is free of debris
- 3) Coupling is tight and leak free
- 4) Valve operates freely through full range and regulates flow
- 5) "OFF" position does fully shut off and flow is stopped
- 6) Nozzle flow is adequate as indicated by pump pressure and nozzle reaction
- 7) Shaper turns freely and adjusts pattern through full range
- 8) Shaper turns into full flush and out of flush with normal flow and pressure restored

Before being placed back in service, nozzles must be inspected to this checklist;

- 1) All controls and adjustments are operational
- 2) Shut off valve (if so equipped) closes off the flow completely
- 3) There is no damage to the appliance that could impair safe operation (e.g. dents, cracks, corrosion, missing, broken or loose parts, damaged markings, or other defects)
- 4) The thread gasket is in good condition
- 5) The waterway is clear of obstructions
- 6) Nozzle is clean and markings are legible
- 7) Coupling is retightened properly
- 8) Shaper is set to desired pattern
- 9) Shutoff handle is stored in the OFF position

NFPA 1962: Standard for the care, use, inspection, service testing, and replacement of fire hose, couplings, nozzles and fire hose appliances. (2013 ed., Section 5.2.2). Quincy, MA: National Fire Protection Agency.



Any nozzle failing any part of the checklist is unsafe for use and must have the problem corrected before use or being placed back into service. Operating a nozzle that has failed the checklist is a misuse of this equipment.