

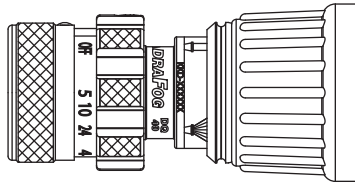

# 1" QuadraFog Series DQ40, DQS40 & DQS40P

## SERVICE PROCEDURE



**DQ40 QuadraFog  
Tip Only**

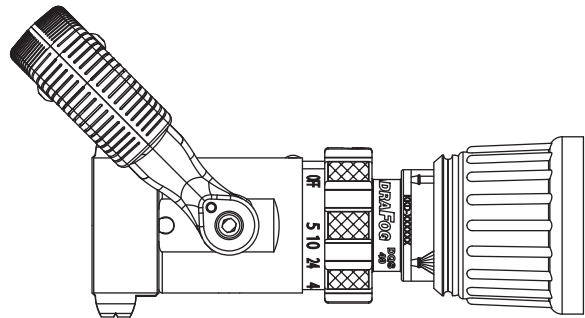

**DQS40 QuadraFog  
Shutoff**

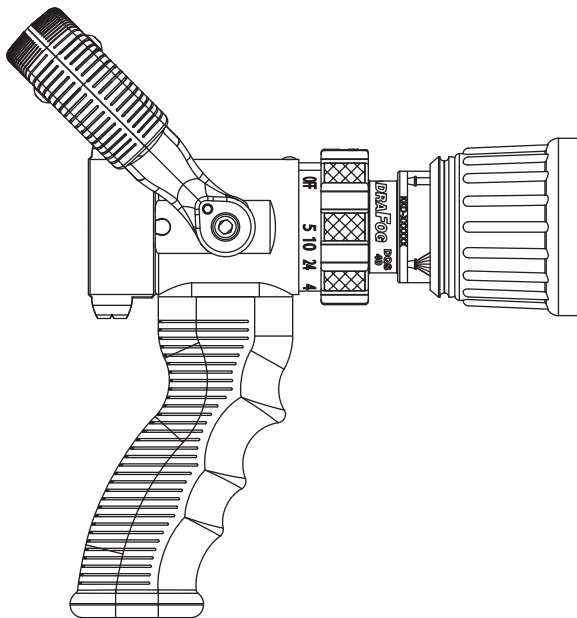

**DQS40P  
QuadraFog  
Shutoff w/Pistol Grip**



### PERSONAL RESPONSIBILITY CODE

The member companies of FEMSA that provide emergency response equipment and services want responders to know and understand the following:

1. Firefighting and Emergency Response are inherently dangerous activities requiring proper training in their hazards and the use of extreme caution at all times.
2. It is your responsibility to read and understand any user's instructions, including purpose and limitations, provided with any piece of equipment you may be called upon to use.
3. It is your responsibility to know that you have been properly trained in Firefighting and /or Emergency Response and in the use, precautions, and care of any equipment you may be called upon to use.
4. It is your responsibility to be in proper physical condition and to maintain the personal skill level required to operate any equipment you may be called upon to use.
5. It is your responsibility to know that your equipment is in operable condition and has been maintained in accordance with the manufacturer's instructions.
6. Failure to follow these guidelines may result in death, burns or other severe injury.



Fire and Emergency Manufacturers and Service Association  
P.O. Box 147, Lynnfield, MA 01940 • www.FEMSA.org

**TASK FORCE TIPS, INC.**  
MADE IN USA • www.tft.com

3701 Innovation Way, Valparaiso, IN 46383-9327 USA  
800-348-2686 • 219-462-6161 • Fax 219-464-7155

## 1.0 INTRODUCTION

The nozzle you have purchased is your primary tool in the battle against fire. It has been manufactured with great care to give you the finest performance possible. All components are top quality and extremely rugged. With occasional inspection and attention, it will serve you for many years. This publication is intended for those who prefer to perform service on their own equipment. Factory service is available, and repair time seldom exceeds one day in our facility. Factory serviced nozzles are repaired by experienced professionals, fully tested and promptly returned functioning to original specifications. Repair charges for non-warranty items are minimal. Task Force Tips assumes no liability for damage to equipment or injury to personnel that is a result of user service.

## 2.0 GENERAL INFORMATION

**THREADED JOINTS** have been secured using Loctite brand thread locking adhesive #271. Disassembly requires a minimal application of heat with a propane or oxyacetylene torch to break the bond. The threads should be heated to approximately 450 degrees F. Excessive heat application will cause damage to adjacent seals and labels. Replacement parts must be reinstalled using Loctite #271, or equivalent. Small vials of Loctite for field service are available; order part # V5010, LOCTITE MINI DISPENSER.

**LUBRICANTS:** If parts are disassembled in an area where o-rings are present, re-assemble using DOW #44 High Temperature Silicone Grease on all o-rings and surfaces that the o-rings contact.

**LABEL REPLACEMENT:** If labels become damaged, remove old labels with a razor knife. Remove adhesive with acetone or methyl ethyl ketone. Surface must be clean, dry and free from grease. Carefully apply new label.

**ORDERING PARTS:** Always specify the serial number of the nozzle when ordering parts. The number is found on the raised rim of the INDEX RING [15]. Be sure to use complete DESCRIPTION and ORDER # as printed on parts list. All requests for couplings must specify thread size. Pricing information will be given at time of order.

**OPERATING INSTRUCTIONS:** See LKF-100 for instructions on Safe Operations and Maintenance

## 3.0 COUPLING AND PISTOL GRIP SERVICE PROCEDURE:

Tools Required: 5/16" Ball Driver

Loctite #271 Thread Locking Adhesive

**GENERAL:** Occasional replacement of the COUPLING GASKET [36] and REAR SEAT [35] is recommended.

**COUPLING REMOVAL:** Remove PORT PLUG [27] from side of BASE [19]. Turn coupling so that hole faces down, and rotate coupling back and forth to allow 3/16 STAINLESS STEEL BALLS [28] to drop out. When all balls are out of the groove, the coupling can be removed.

**COUPLING INSTALLATION:** Put the coupling onto the mating part and load 26 STAINLESS STEEL BALLS [28] into the ball groove through the port in the valve. Insertion of the balls is easier if the coupling is rotated slightly back and forth as the balls are loaded. Insert PORT PLUG [27] into port on side of BASE [19].

**BOLT-ON PISTOL GRIP REMOVAL / INSTALLATION:** The PISTOL GRIP [25] is held on by a SOCKET HEAD CAP SCREW [24] and WASHER [35]. Remove screw with a 5/16" Ball Driver. To reinstall, clean thread and apply Loctite #271. Tighten screw to 95 in-lbs.

## 4.0 VALVE and HANDLE SERVICE PROCEDURE

See Ball Valve Handle Repair Kit Instructions – (LKR-200)

## 5.0 FRONT END SERVICE PROCEDURE

Tools Required: 1/8" Allen (Hex) Wrench

3/16" Allen (Hex) Wrench

1/8" Two Prong Face Spanner Wrench

Strap Wrench

Razor Blade Knife

Dow #44 High Temperature Silicone Grease

Torch, oxyacetylene or propane

Loctite #271 Thread Locking Adhesive

Flow Meter

Pressure Gage

## 5.1 FRONT END DISASSEMBLY SEQUENCE

**BUMPER and HEAD REMOVAL:** Using a razor blade knife, cut through one side of the BUMPER [3] from top to bottom then remove BUMPER [3] from HEAD [4]. Once the BUMPER [3] is removed, heat the CUPS [6] and remove the CUPS [6] using a 3/16" Allen wrench. Now the "V" FOLLOWERS [7] can be removed from the HEAD [4] and the HEAD [4] can be slid off the GALLONAGE SLEEVE [9].

**DEFLECTOR REMOVAL:** Cut DEFLECTOR LABEL [1] off DEFLECTOR [2] to expose spanner wrench holes. Remove DEFLECTOR [2] using a spanner wrench.

**GALLONAGE SLEEVE REMOVAL:** Heat and remove DETENT SCREW [14] from INDEX RING [15] using a 1/8" Allen wrench. Be careful not to heat/damage NAME LABEL [10] (a wet rag wrapped around this area will help). Now that the DETENT SCREW [14] is removed the SPRING [13], and TORLON BALL [12] can be removed from the INDEX RING [15]. Unscrew GALLONAGE SLEEVE [9] from INDEX RING [15] by rotating the INDEX RING [15] (Note: threads in Index Ring are left-hand threads) the GALLONAGE SLEEVE [9] will not rotate because of the KEY PINS [11]. Once the GALLONAGE SLEEVE [9] is free of the INDEX RING [15], slide the GALLONAGE SLEEVE [9] off the BASE [19]. Remove KEY PINS [11] from GALLONAGE SLEEVE [9]. The O-RING [8] and O-RING [18] should be removed and replaced after disassembly.

## 5.2 FRONT END ASSEMBLY SEQUENCE

**GALLONAGE SLEEVE INSTALLATION:** Assemble TORLON BALL [12], DETENT SPRING [13], and DETENT SCREW [14] into a subassembly. Grease detent grooves and cam grooves in GALLONAGE SLEEVE [9]. Grease the inside of the GALLONAGE SLEEVE [9] and the slots in the BASE [19]. Install O-RING [18] on the BASE [19]. Slide GALLONAGE SLEEVE [9] over the BASE [19] and into the INDEX RING [15]. Thread INDEX RING [15] onto GALLONAGE SLEEVE [9]. Thread the detent subassembly into INDEX RING [15] (do not apply Loctite and tighten completely) making sure that detent assembly lines up with the detent groove. Also make sure that the word "FLUSH" on the INDEX RING [15] lines up with arrow on the NAME LABEL [16]. Apply Loctite 271 to KEY PINS [11] and insert through the GALLONAGE SLEEVE [9] into the BASE [19]. Go back and apply Loctite 271 to detent assembly then thread flush to surface of INDEX RING [15]. Install O-RING [8] on the GALLONAGE SLEEVE [9].

**BUMPER and HEAD INSTALLATION:** Apply grease to cam grooves in GALLONAGE SLEEVE [9] and to the I.D. of the HEAD [4]. Apply grease to "V" FOLLOWERS [7] and place each one into a CUP [6]. Slide HEAD [4] over end of GALLONAGE SLEEVE [9] making sure that the holes in HEAD [4] are lined up with cam grooves in the GALLONAGE SLEEVE [9]. Straight stream icon on PATTERN LABEL [5] should line up with arrow on NAME LABEL [16]. Apply Loctite 271 to cup subassemblies and thread through HEAD [4] and into cam groove in GALLONAGE SLEEVE [9]. Make sure cup subassemblies are not threaded too tight into barrel. Slide BUMPER [3] over the HEAD [4] with nubs on the I.D. of the bumper lining up with the empty holes in the HEAD [4].

**DEFLECTOR INSTALLATION:** Apply a small amount of Loctite 271 to threads on end of BASE [19]. Start screwing on the DEFLECTOR [2] by hand, to make sure it is going on straight. Continue to screw the DEFLECTOR [2] in using a spanner wrench. Set the nozzle to the 10 gpm flow rate. Adjust gap between DEFLECTOR [2] and face of GALLONAGE SLEEVE [9] per chart below. Make sure the DEFLECTOR [2] is not loose before testing. Test nozzle to ensure that nozzle generates the proper pressure at the correct flow rate – adjust DEFLECTOR [2] if needed. Once the DEFLECTOR [2] is set, clean and dry it; then apply DEFLECTOR LABEL [1].

FLOW RATE	PRESSURE	GAP SIZE
10 GPM	100 PSI	0.024"
40 l/min	7 bar	0.62mm

## 6.0 PROBLEMS

If you have any questions or problems, please feel free to call for assistance.

TASK FORCE TIPS INC., 3701 Innovation Way, Valparaiso, IN 46383-9327  
(219)-462-6161 • (800)-348-2686

## 7.0 EXPLODED VIEW & PART NUMBERS

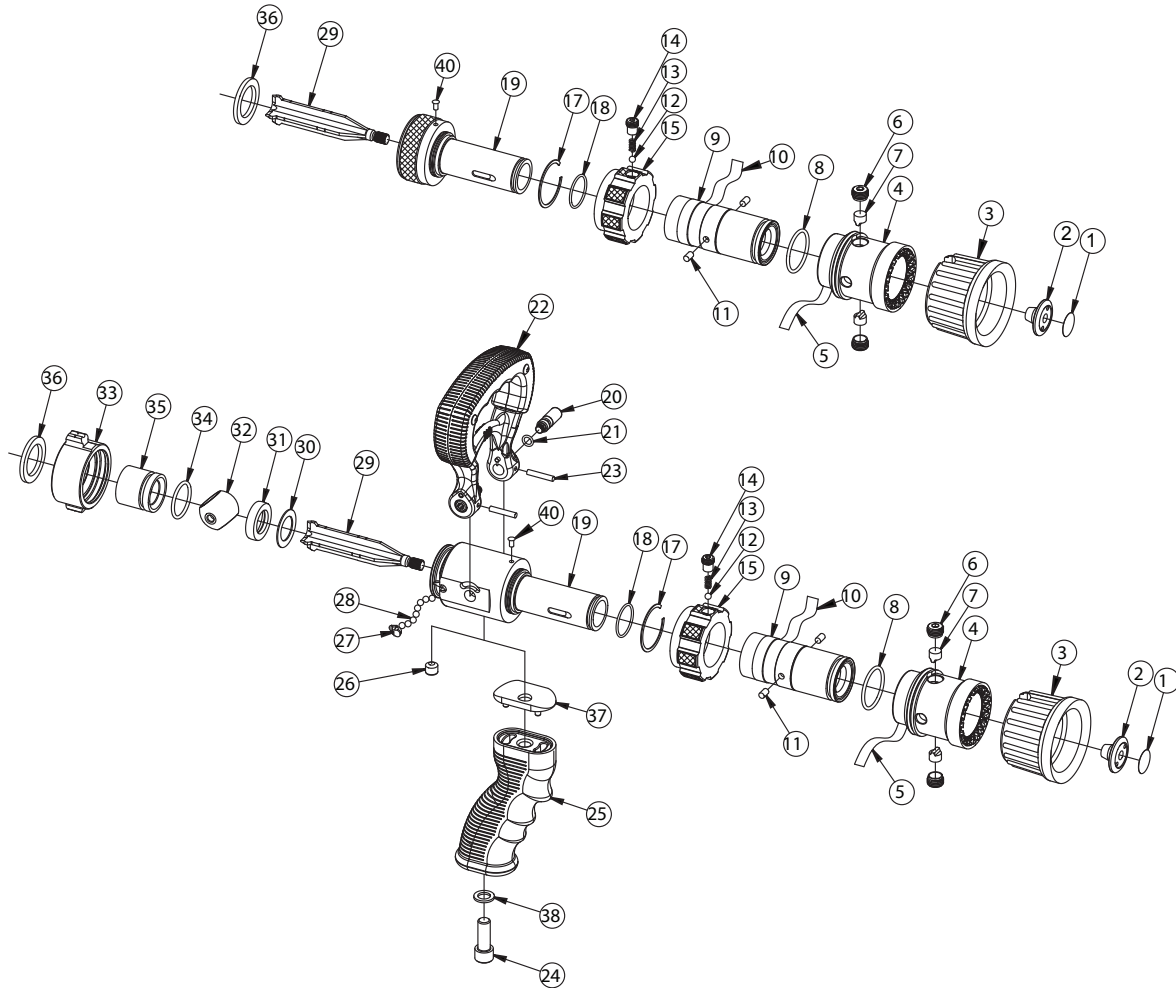

ITEM	DESCRIPTION	QTY	PART #
1	DQ DEFLECTOR LABEL	1	DL10
2	DQ DEFLECTOR	1	DQ210
3	DQ BUMPER	1	DQ275
4	HEAD	1	DQ220
5	DQ PATTERN LABEL	1	DL200
6	CUP	2	DQ260
7	V FOLLOWER	2	DQ265
8	O-RING-123	1	VO-123
9*	GALLONAGE SLEEVE DQ	1	DQ240 DQ241
10	NAME LABEL	1	DL241
11	DQ KEY PINS	2	DQ250
12	3/16" TORLON BALL	1	V2120-TORLON
13	SPRING HELICAL COMPRESSION	1	VM4195
14	DETENT SCREW	1	D290
15*	INDEX RING	1	DQ230 DQ231
17	SMALLEY RING	1	V4245
18	O-RING-021	1	VO-021
19*	DQ BASE	1	DQ201 DQ205**
20	75 TRUNNION	2	D07540
21	O-RING-010	2	VO-010

ITEM	DESCRIPTION	QTY	PART #
22	HANDLE SUBASSEMBLY	1	DQ860
	75 SHUTOFF HANDLE	1	D07560
	BLACK HANDLE COVER	2	HM625-BLK
	8-32 X 3/8 BUTTON HEAD SCREW	4	VT08E32BH375
	75 STOP PIN	2	D07550
23	SPIROL PIN	2	V1900
24	3/8-16 X 7/8" SOCKET HEAD SCREW	1	VT37-16SH1.0
25	PISTOL GRIP - BLACK	1	HM692-BLK
26	3/8-16 X 5/16" SET SCREW	1	VT37-16SS312
27	PORT PLUG	1	B770
28	3/16" SS BALL	26	V2120
29	STEM	1	DQ280
30	BELLEVILLE WASHER	1	D07590
31	75 FRONT SEAT	1	D07570
32	75 BALL	1	D07530
33**	COUPLING 1.0"	1	D07597
34	O-RING-120	1	VO-120
35	75 REAR SEAT	1	D07580
36	GASKET	1	V3040
37	GRIP SPACER D075	1	HM693-D
38	FLAT WASHER	1	VM4901
40	6 X 1/4 SS DRIVE SCREW	1	VT06E00DS250
* - CONSULT FACTORY FOR SPECIFIC PART NUMBERS			
** - STATE DESIRED THREAD WHEN ORDERING			

**TASK FORCE TIPS, INC.**  
MADE IN USA • www.tft.com

**3701 Innovation Way, Valparaiso, IN 46383-9327 USA**  
**800-348-2686 • 219-462-6161 • Fax 219-464-7155**