



ER Bubble Cup® Nozzles

INSTRUCTIONS FOR INSTALLATION, OPERATION, AND MAINTENANCE

⚠ WARNING

Understand manual before use. Operation of this device without understanding the manual and receiving proper training is a misuse of this equipment. Obtain safety information at tft.com/serial-number.

This equipment is intended for use by trained and qualified emergency services personnel for firefighting. All personnel using this equipment shall have completed a course of education approved by the Authority Having Jurisdiction (AHJ).

This instruction manual is intended to familiarize firefighters and maintenance personnel with the operation, servicing, and safety procedures associated with this product. This manual should be kept available to all operating and maintenance personnel.

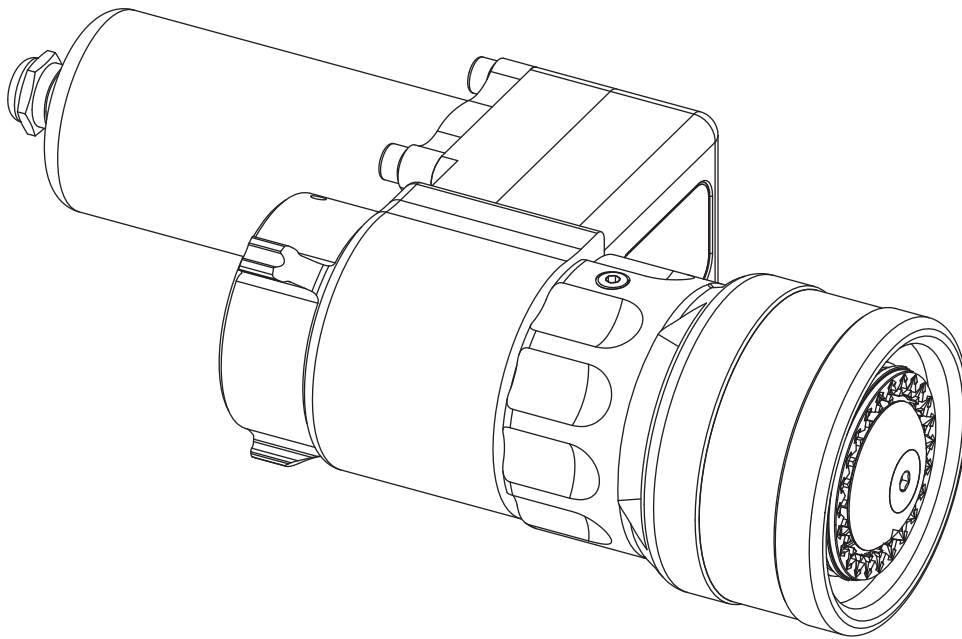

TASK FORCE TIPS LLC
MADE IN USA · tft.com

3701 Innovation Way, Valparaiso, IN 46383-9327 USA
800-348-2686 · 219-462-6161 · Fax 219-464-7155

TABLE OF CONTENTS

- 1.0 MEANING OF SAFETY SIGNAL WORDS
- 2.0 SAFETY
- 3.0 GENERAL INFORMATION
 - 3.1 VARIOUS MODELS AND TERMS
 - 3.2 SPECIFICATIONS
 - 3.3 USE WITH SALT WATER
 - 3.4 NOZZLE COUPLINGS
- 4.0 ELECTRICAL INSTALLATION
- 5.0 FLOW CHARACTERISTICS
 - 5.1 REACH, TRAJECTORY, AND NOZZLE REACTION
- 6.0 NOZZLE CONTROLS
 - 6.1 PATTERN CONTROL
 - 6.2 ASPIRATING SLEEVE
- 7.0 USE WITH FOAM
- 8.0 FLUSHING DEBRIS
- 9.0 WARRANTY
- 10.0 MAINTENANCE
 - 10.1 FIELD LUBRICATION
 - 10.2 SERVICE TESTING
 - 10.3 REPAIR
- 11.0 EXPLODED VIEWS AND PARTS LISTS
- 12.0 OPERATION AND INSPECTION CHECKLIST

⚠ DANGER

PERSONAL RESPONSIBILITY CODE

The member companies of FEMSA that provide emergency response equipment and services want responders to know and understand the following:

1. Firefighting and Emergency Response are inherently dangerous activities requiring proper training in their hazards and the use of extreme caution at all times.
2. It is your responsibility to read and understand any user's instructions, including purpose and limitations, provided with any piece of equipment you may be called upon to use.
3. It is your responsibility to know that you have been properly trained in Firefighting and/or Emergency Response and in the use, precautions, and care of any equipment you may be called upon to use.
4. It is your responsibility to be in proper physical condition and to maintain the personal skill level required to operate any equipment you may be called upon to use.
5. It is your responsibility to know that your equipment is in operable condition and has been maintained in accordance with the manufacturer's instructions.
6. Failure to follow these guidelines may result in death, burns or other severe injury.



Fire and Emergency Manufacturers and Service Association
P.O. Box 147, Lynnfield, MA 01940 • www.FEMSA.org

SUPPORTING MATERIALS

The following documents contain supporting safety and operating information pertaining to the equipment described in this manual.

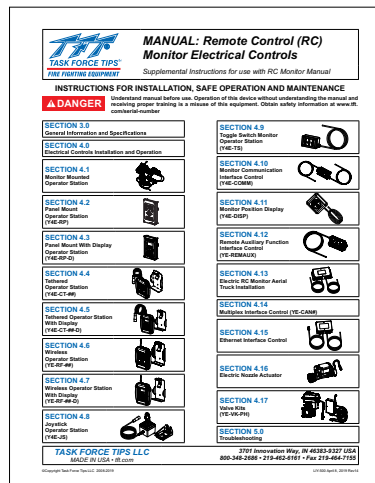



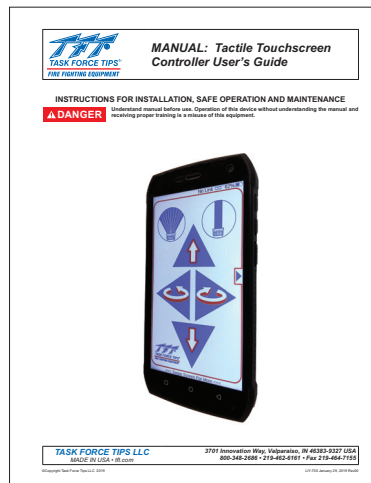

LIY-500
Remote Control (RC) Monitor
Electrical Controls









LIY-700
Tactile Touchscreen Controller
User's Guide

1.0 MEANING OF SAFETY SIGNAL WORDS

A safety related message is identified by a safety alert symbol and a signal word to indicate the level of risk involved with a particular hazard. Per ANSI Z535.6, the definitions of the four signal words are as follows:

	DANGER indicates a hazardous situation which, if not avoided, will result in death or serious injury.
	WARNING indicates a hazardous situation which, if not avoided, could result in death or serious injury.
	CAUTION indicates a potentially hazardous situation which, if not avoided, could result in minor or moderate injury.
	NOTICE is used to address practices not related to physical injury.

2.0 SAFETY

	An inadequate supply of pressure and/or flow will cause an ineffective stream and can result in injury or death. Choose operating conditions to deliver adequate fire suppression. See flow graphs.
	This equipment is intended for use by trained personnel for firefighting. Use of this equipment for other purposes may involve hazards not addressed by this manual. Seek appropriate guidance and training to reduce risk of injury.
	Injury or damage can occur from an inadequately supported monitor. The mounting must be capable of supporting the nozzle reaction force.
	Equipment may be damaged if frozen while containing significant amounts of water. Such damage may be difficult to detect visually. Subsequent pressurization can lead to injury or death. Any time the equipment is subject to possible damage due to freezing, it must be tested and approved for use by qualified personnel before being considered safe for use.
	Application of water or foam solutions on energized electrical equipment could cause electrocution. Serious injury or death could result. Assume circuits are energized until confirmed to be de-energized. Do not apply water or foam to energized electrical equipment.
	The stream exiting a nozzle is powerful and capable of causing injury and property damage. Make sure the nozzle is securely attached and pointing in a safe direction before water is turned on. Do not direct water stream to cause injury or damage to persons or property.
	To prevent mechanical damage, do not drop or throw equipment.

3.0 GENERAL INFORMATION

Task Force Tips ER Bubble Cup nozzles have a clean, far reaching, dual flow straight and fog pattern that is designed for use with the EF1 monitor. The nozzle stream is adjustable from off (closed), to low flow straight stream, high flow straight stream, and fog. The off position may eliminate the need for a downstream valve. The rugged construction is compatible with the use of fresh water as well as fire fighting foam solutions. The ER Bubble Cup nozzles provide reach and adjustable foam aspiration when the aspirating sleeve is extended.

3.1 VARIOUS MODELS AND TERMS

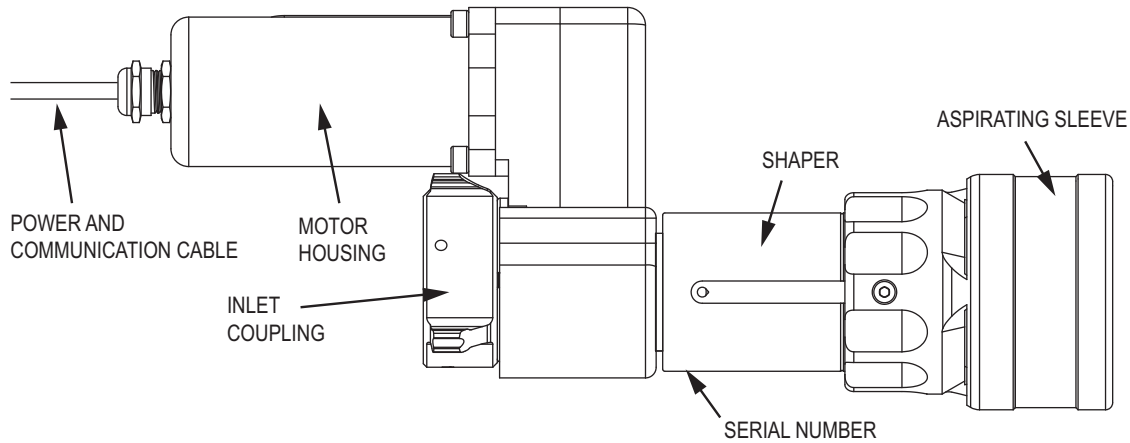

Figure 3.1

3.2 SPECIFICATIONS

Maximum nozzle inlet pressure*	100 psi	7 bar
Operating temperature of fluid	33 to 120°F	1 to 50°C
Storage temperature range of fluid	-40 to 150°F	-40 to 65°C
Materials used	Aluminum 6000 series hard anodized MIL 8625 class 3 type 2, stainless steel 300 series, nylon 6-6, nitrile rubber, acrylonitrile styrene acrylate	
*Consult factory for higher pressure applications		

Table 3.2

3.3 USE WITH SALT WATER

Use with salt water is permissible provided the equipment is thoroughly cleaned with fresh water after each use. The service life of the equipment may be shortened due to the effects of corrosion, and is not covered under warranty.

3.4 NOZZLE COUPLINGS

NH (National Hose Threads) threads are standard on all nozzles. Other threads such as NPSH (National Pipe Straight Hose) may be specified at time of order.

CAUTION Mismatched or damaged waterway connections may cause equipment to leak or uncouple under pressure. Failure could result in injury. Equipment must be mated to matched connections.

CAUTION Dissimilar metals coupled together can cause galvanic corrosion that can result in the inability to uncouple the connection, or complete loss of engagement over time. Failure could cause injury. Per NFPA 1962, if dissimilar metals are left coupled together, an anti-corrosive lubricant should be applied to the connection and the coupling should be disconnected and inspected at least quarterly.

4.0 ELECTRICAL INSTALLATION

For nozzle installation, refer to LIY-500 Remote Control (RC) Monitor Electrical Controls (shipped with TFT monitors or available at tft.com).

WARNING This device is not rated as ignition proof, explosion proof, or intrinsically safe. Use only in locations with adequate ventilation and no hazard of flammable vapor buildup.

5.0 FLOW CHARACTERISTICS

At each flow setting, the nozzle is set to a predetermined fixed orifice. Relationship of flow and nozzle pressure at each setting is shown below.

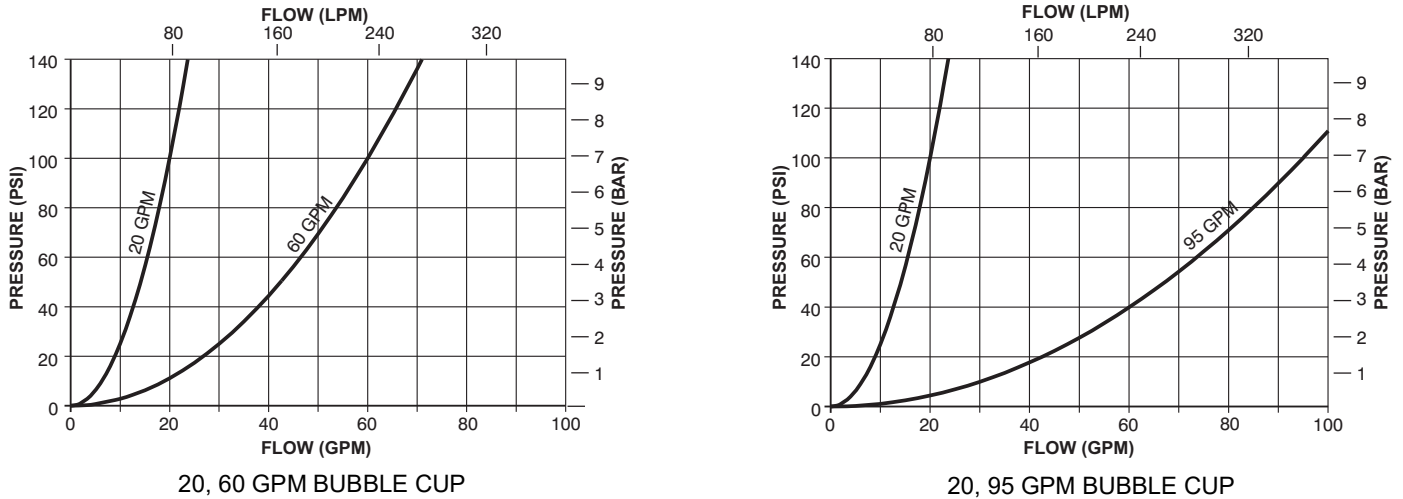
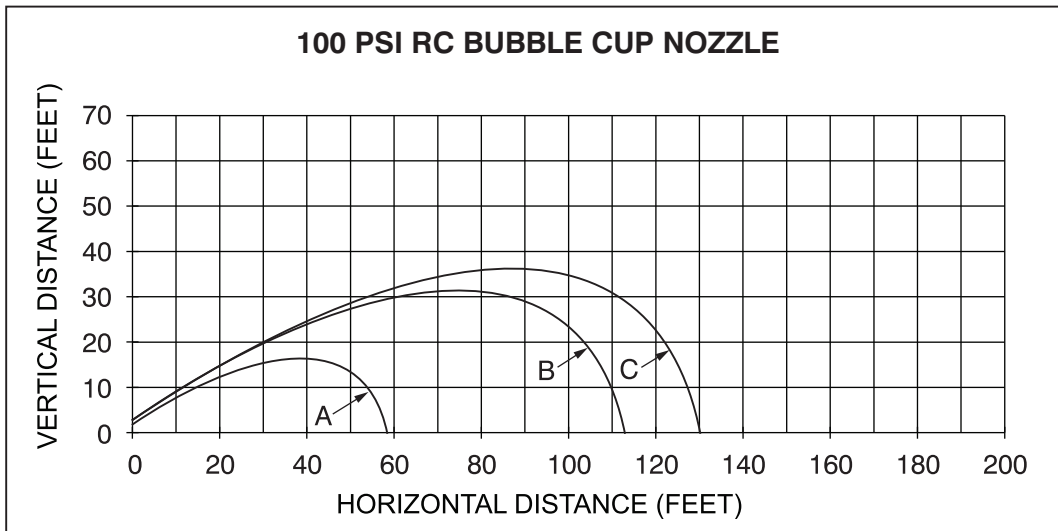

Figure 5.0

5.1 REACH, TRAJECTORY, AND NOZZLE REACTION

Trajectory, reach, and reaction numbers are provided for reference. All data based on 30 degree nozzle discharge angle, in straight stream setting. Actual trajectories, reach, and reactions may vary with wind conditions, discharge angle (elevation), stream setting, fluid type, fluid/water ratio, fluid temperature, pressure, and flow at the nozzle. It is the operator's responsibility to determine that the system provides adequate reach for the intended purpose.



CURVE	GPM FLOW	PRESSURE PSI	LBS REACTION
A	20	100	10
B	60	100	30
C	95	100	48

CURVE	L/min FLOW	PRESSURE BAR	KGf REACTION
A	75	7	4.5
B	227	7	13.6
C	360	7	21.7

Figure 5.1

6.0 NOZZLE CONTROLS

ER Bubble Cup nozzles have a shutoff position controlled by the electric drive.

The shutoff is a low-cost alternative to a separate remote controlled valve. Slight fuzzing occurs as debris gradually wears the valve seat. Over time, this may result in minor dripping. The valve seat is a nylon washer under the baffle. The valve seat is easily replaced by removing a screw holding the baffle (use 3/16" hex key). The seat is a wear-type part that is not covered under warranty. Order part #F650 SEAT. If the potential for dripping is unacceptable, then a separate manual shutoff valve with drain at the system's low point is suggested.

Electrical controls are connected to the monitor with a 6-pin plug. Refer to LIY-700, Manual: Tactile Touchscreen Controller Users Guide, for electronic remote operation.

6.1 PATTERN CONTROL

NOTICE

If the nozzle is manually adjusted with the power off, its needs to be reset for accurate electronic control. Activate the electronic control to the off position for at least 3 seconds to reset.

CAUTION

Dents or nicks in the nozzle tip can seriously affect the stream reach or pattern, which may increase the risk of injury due to exposure. Care must be taken to avoid dents or nicks in the nozzle tip.

ER Bubble Cup nozzles have full pattern control from OFF through low flow patterns and high flow patterns.

To operate the nozzle manually: Turn the SHAPER clockwise (as seen from the operating position behind the nozzle) to move to the straight stream position. The pattern can be adjusted either by operating the electric actuator or by manually rotating the shaper.

When operating electrically, the shaper will move in slow mode from OFF in the following sequence:

1. First FOG Button Press - OFF to low flow straight stream and stop (to prevent unintentional excessive water usage).
2. Pressing the fog button again will move the shaper in slow mode until low flow medium fog is achieved.
3. Holding the FOG button or pressing again after low flow medium fog, will move the shaper in fast mode through:
 - high flow straight stream
 - high flow medium fog
 - stopping at high flow wide fog.
4. Release the fog button at any time to stop the shaper at the desired flow/pattern.

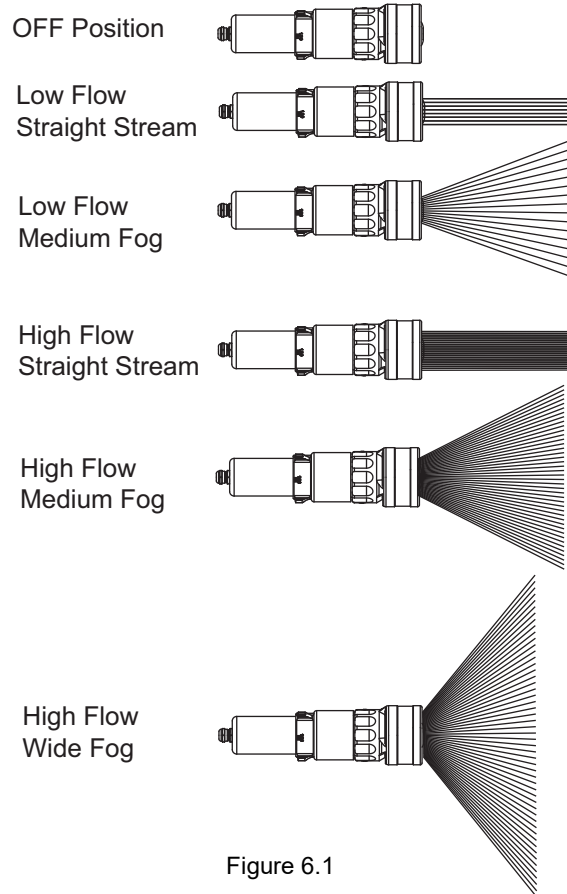

Figure 6.1

Since the stream trim point varies with the flow, the stream should be 'trimmed' after changing the flow to obtain the straightest and furthest reaching stream. The nozzle reaction is greatest when the shaper is in the straight-stream position.

To properly trim a stream, first open the pattern to a narrow fog. Then close the stream to parallel to give maximum reach.

NOTICE

Turning the shaper further forward will cause stream crossover and reduce the reach of the nozzle.

6.2 ASPIRATING SLEEVE

The ER Bubble Cup nozzle is capable of producing aspirated foam as well as a conventional straight stream and wide protective fog pattern. The ER Bubble Cup functions just like a fog nozzle when the aspirating sleeve is in the retracted position.

To use the aspirating feature of the Bubble Cup, grip the aspiration sleeve and pull it forward to it's extended position.

In the extended position, fog patterns are disabled in order to aspirate foam. Adjusting the shaper position will control aspiration and reach. The aspirator may be gripped and pushed back to it's retracted position if fog patterns are needed.

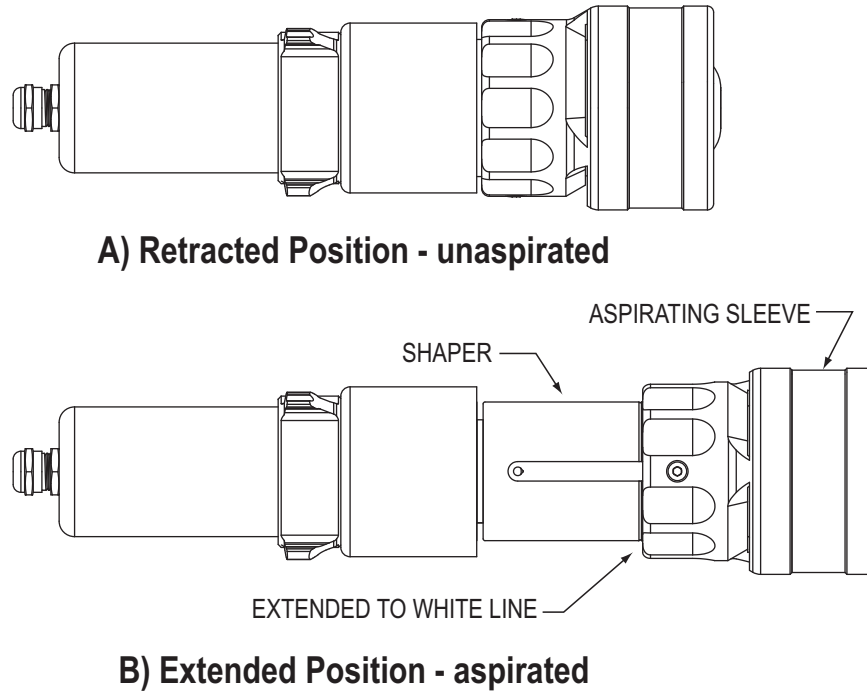

Figure 6.2

7.0 USE WITH FOAM

The nozzle may be used with foam solutions. Refer to fire service training by the Authority Having Jurisdiction (AHJ) for the proper use of foam.

WARNING

For Class B fires, lack of foam or interruption in the foam stream can cause a break in the foam blanket and greatly increase the risk of injury or death. Follow procedures established by the AHJ for the specific fuel and conditions.

WARNING

Improper use of foam or using the wrong type of foam can result in illness, injury, or damage to the environment. Follow foam manufacturer's instructions and fire service training as directed by the AHJ.

WARNING

Use of compressed air foam (CAF) with hand held nozzles can cause sudden surges in nozzle reaction force resulting in risk of injury or death from loss of footing or hose whipping. Be prepared for sudden changes in nozzle reaction caused by:

- Slug loading (Loss of foam concentrate sends slugs of air and water into the nozzle)
- Sudden release of built-up pressure in the hose when opening a nozzle

8.0 FLUSHING DEBRIS

WARNING

Large amounts or pieces of debris may be unflushable and can reduce the flow of the nozzle resulting in an ineffective flow. In the event of a blockage, it may be necessary to retreat to a safe area, uncouple the nozzle and remove debris.

Debris in the water may get caught inside the nozzle. This trapped material will cause poor stream quality, shortened reach, and reduced flow. Debris can usually be cleared by moving the shaper to the wide fog position at high flow for a couple seconds and then resuming operation. If debris remains trapped in the nozzle:

1. Shut off flow to the nozzle.
2. Move the stream shaper to the wide fog position.
3. Unscrew baffle retaining screw using a 3/16" hex key.
4. Remove baffle retaining screw, spring washer, baffle, and seat.
5. Remove debris. Flow water to flush if necessary.
6. Apply blue Loctite to screw threads. Reinstall seat, baffle, spring washer, and baffle retaining screw (make sure seat is centered on baffle and spring washer is oriented as shown below)
7. Torque baffle retaining screw to 180 in-lb (20 N-m).

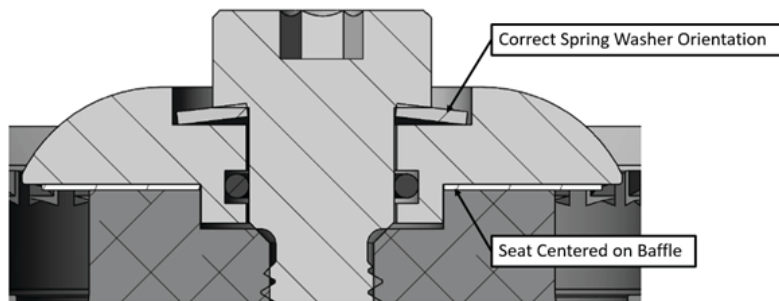

Figure 8.0

NOTICE

Spring washer orientation is critical to proper and consistent operation. Failure to orient the spring correctly can result in inadvertent lockup of stream shaper.

9.0 WARRANTY

Task Force Tips LLC, 3701 Innovation Way, Valparaiso, Indiana 46383-9327 USA ("TFT") warrants to the original purchaser of its products ("equipment"), and to anyone to whom it is transferred, that the equipment shall be free from defects in material and workmanship during the five (5) year period from the date of purchase. TFT's obligation under this warranty is specifically limited to replacing or repairing the equipment (or its parts) which are shown by TFT's examination to be in a defective condition attributable to TFT. To qualify for this limited warranty, the claimant must return the equipment to TFT, at 3701 Innovation Way, Valparaiso, Indiana 46383-9327 USA, within a reasonable time after discovery of the defect. TFT will examine the equipment. If TFT determines that there is a defect attributable to it, TFT will correct the problem within a reasonable time. If the equipment is covered by this limited warranty, TFT will assume the expenses of repair.

If any defect attributable to TFT under this limited warranty cannot be reasonably cured by repair or replacement, TFT may elect to refund the purchase price of the equipment, less reasonable depreciation, in complete discharge of its obligations under this limited warranty. If TFT makes this election, claimant shall return the equipment to TFT free and clear of any liens and encumbrances.

This is a limited warranty. The original purchaser of the equipment, any person to whom it is transferred, and any person who is an intended or unintended beneficiary of the equipment, shall not be entitled to recover from TFT any consequential or incidental damages for injury to person and/or property resulting from any defective equipment manufactured or assembled by TFT.

It is agreed and understood that the price stated for the equipment is in part consideration for limiting TFT's liability. Some states do not allow the exclusion or limitation of incidental or consequential damages, so the above may not apply to you.

TFT shall have no obligation under this limited warranty if the equipment is, or has been, misused or neglected (including failure to provide reasonable maintenance) or if there have been accidents to the equipment or if it has been repaired or altered by someone else.

THIS IS A LIMITED EXPRESS WARRANTY ONLY. TFT EXPRESSLY DISCLAIMS WITH RESPECT TO THE EQUIPMENT ALL IMPLIED WARRANTIES OF MERCHANTABILITY AND ALL IMPLIED WARRANTIES OF FITNESS FOR A PARTICULAR PURPOSE. THERE IS NO WARRANTY OF ANY NATURE MADE BY TFT BEYOND THAT STATED IN THIS DOCUMENT.

This limited warranty gives you specific legal rights, and you may also have other rights which vary from state to state.

10.0 MAINTENANCE

TFT products are designed and manufactured to be damage resistant and require minimal maintenance. However, as the primary firefighting tool upon which your life depends, it should be treated accordingly. To help prevent mechanical damage, do not drop or throw equipment.

10.1 FIELD LUBRICATION

All Task Force Tips nozzles are factory lubricated with high quality silicone grease. This lubricant has excellent wash out resistance, providing long term performance in firefighting nozzles. If your agency has unusually hard or sandy water, the moving parts of the nozzle may be affected. Foam agents and water additives contain soaps and chemicals that may break down the factory lubrication.

The moving parts of the nozzle should be checked on a regular basis for smooth and free operation, and for signs of damage. **IF THE NOZZLE IS OPERATING CORRECTLY, THEN NO ADDITIONAL LUBRICANT IS NEEDED.** Any nozzle that is not operating correctly should be immediately removed from service. The nozzle can be returned to the factory at any time for a complete checkup and re-lubrication with silicone grease.

The field use of Break Free CLP (spray or liquid) lubricant will help to temporarily restore the smooth and free operation of the nozzle. These lubricants do not have the washout resistance and long-term performance of the silicone grease. Once Break Free CLP is applied, re-application will be needed on a regular basis until the nozzle can be returned to the factory for a complete checkup and re-lubrication with silicone grease.



Aerosol lubricants contain solvents that can swell O-Rings if applied in excess. The swelling can inhibit smooth operation of the moving parts. When used in moderation, as directed, the solvents quickly evaporate without adversely swelling the O-Rings.

10.2 SERVICE TESTING

In accordance with NFPA 1962, equipment must be tested a minimum of annually. Units failing any part of this test must be removed from service, repaired and retested upon completion of the repair.

10.3 REPAIR

Factory service is available with repair time seldom exceeding one day in our facility. Factory serviced equipment is repaired by experienced technicians, wet tested to original specifications, and promptly returned. Any returns should include a note as to the nature of the problem and whom to reach in case of questions.

Repair parts and service procedures are available for those wishing to perform their own repairs. Task Force Tips assumes no liability for damage to equipment or injury to personnel that is a result of user service. Contact the factory or visit the web site at tft.com for parts lists, exploded views, test procedures and troubleshooting guides.

Performance tests shall be conducted on the equipment after a repair, or anytime a problem is reported to verify operation in accordance with TFT test procedures. Consult factory for the procedure that corresponds to the model and serial number of the equipment. Any equipment which fails the related test criteria should be removed from service immediately. Troubleshooting guides are available with each test procedure or equipment can be returned to the factory for service and testing.



Any alterations to the product or its markings could diminish safety and constitutes a misuse of this product.



All replacement parts must be obtained from the manufacturer to assure proper operation of the device.

11.0 EXPLODED VIEWS AND PARTS LISTS

Exploded views and parts lists are available at tft.com/serial-number.

12.0 OPERATION AND INSPECTION CHECKLIST

BEFORE EACH USE, the nozzle must be inspected to this checklist:

1. There is no obvious damage such as missing, broken or loose parts, damaged labels etc.
2. Waterway is clear of obstructions
3. Coupling is tight and leak free
4. Valve operates freely through full range and regulates flow
5. "OFF" position shuts off fully and flow is stopped
6. Nozzle flow is adequate as indicated by pump pressure and nozzle reaction
7. Shaper turns freely and adjusts pattern through full range
8. Shaper detent (if so equipped) operates smoothly and positively.

BEFORE BEING PLACED BACK IN SERVICE, nozzles must be inspected to this checklist:

1. *All controls and adjustments are operational*
2. *Shut off valve (if so equipped) closes off the flow completely*
3. *There are no broken or missing parts*
4. *There is no damage to the nozzle that could impair safe operation (e.g. dents, cracks, corrosion or other defects)*
5. *The thread gasket is in good condition*
6. *The waterway is clear of obstructions*
7. *Nozzle is clean and markings are legible*
8. *Coupling is retightened properly*
9. *Shaper is set to desired pattern*
10. *Shutoff handle is stored in the OFF position*

NFPA 1962: Standard for the care, use, inspection, service testing, and replacement of fire hose, couplings, nozzles and fire hose appliances. Quincy, MA: National Fire Protection Agency



Equipment failing any part of the checklist is unsafe for use and must have the problem corrected before use or being placed back into service. Operating equipment that has failed the checklist is a misuse of this equipment.