

INSTRUCTIONS FOR INSTALLATION, SAFE OPERATION AND MAINTENANCE

⚠ WARNING

Understand manual before use. Operation of this device without understanding the manual and receiving proper training is a misuse of this equipment. Obtain safety information at www.tft.com/serial-number

This Instruction Manual is intended to familiarize firefighters and maintenance personnel with the operation, servicing and safety procedures associated with the Hydrant Under Monitor (HUM).

This Instruction Manual should be kept available to all operating and maintenance personnel.

RATED OPERATING PRESSURE: 300 psi (21 bar)

SAFE OPERATING RANGE FOR MONITOR OUTLET:

Up to 2500 gpm below 130 psi (9500 l/min @ 9 bar)*

Up to 2000 gpm below 200 psi (8000 l/min @ 14 bar)*

Up to 1600 gpm @ 300 psi maximum (6000 l/min @ 21 bar)*

* valid for monitor outlets up to 20" (508mm) tall from the HUM outlet. Read section 4.3 for details.

HYDROSTATIC PROOF TEST: 1200 psi (83 bar)**

**Do not exceed the rated operating pressure of 300 psi (21 bar). The hydrostatic proof test is performed on a sample valve to ensure it does not visibly rupture, crack or permanently distort at 4 times the rated operating pressure. The purpose of the proof test is to be confident the valve design may be safely operated at the rated operating pressure.

SAMPLE CONFIGURATIONS

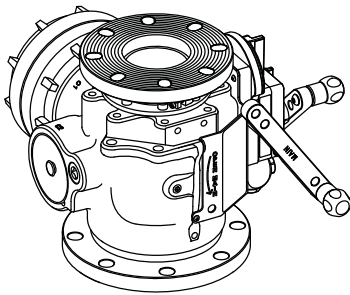

Model ZBAD31X00
with 4" ANSI 150 on side B,
6" Storz on port C1
and blind plug on port C2

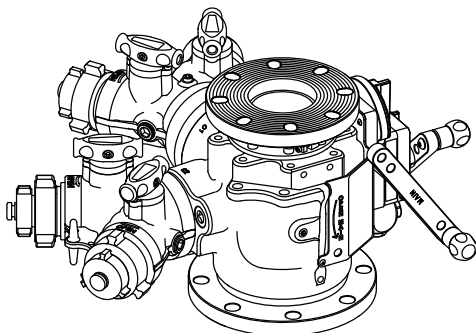

Model ZBAD38J8J
with 4" ANSI 150 on side B
and 2.5" gated wyes on
both ports C1 and C2

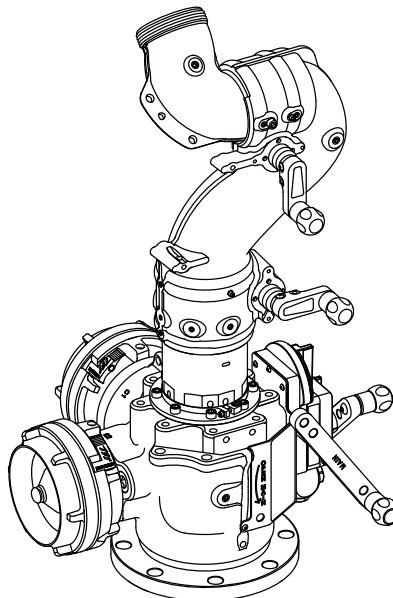

Model ZBAD11T1T
with integrated TFT Typhoon on side B
and 5" Storz on both ports C1 and C2

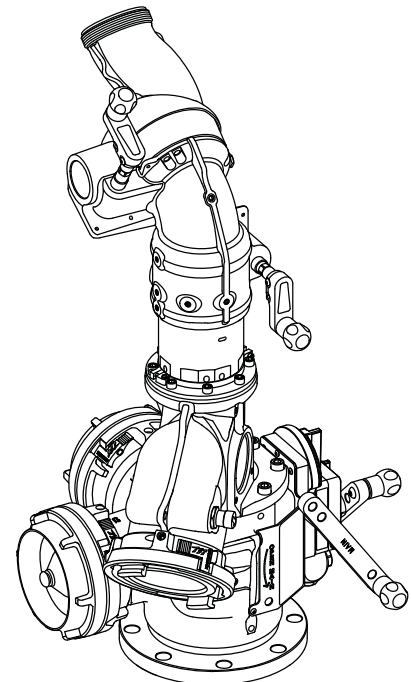

Model ZBAD01T1T
with integrated Booster,
TFT Monsoon on side B and
5" Storz on both ports C1 and C2

Table Of Contents

1.0	MEANING OF SAFETY SIGNAL WORDS.....	3
2.0	SAFETY	3
3.0	GENERAL INFORMATION	4
3.1	SPECIFICATIONS	4
3.2	CORROSION RESISTANCE	4
3.3	USE WITH SALT WATER	4
3.4	PARTS IDENTIFICATION AND INTENDED ORIENTATION	5
3.5	OPTIONS, DIMENSIONS AND WEIGHTS	6
4.0	INSTALLATION	12
4.1	STRUCTURAL REQUIREMENTS	12
4.2	FLANGE INSTALLATION.....	12
4.3	MONITOR INSTALLATION AND COMPATIBILITY	12
5.0	USE	15
5.1	VALVE OPERATION AND VALVE POSITION INDICATORS.....	15
5.2	TYPICAL USE SCENARIOS.....	16
5.3	DRAINING RESIDUAL WATER	18
6.0	EXPLODED VIEWS AND PARTS LISTS	19
6.1	OVERALL ASSEMBLY	19
6.2	MAIN HALF BALL [A] AND MONITOR HALF BALL [B]	21
6.3	MAIN VALVE GEARBOX [C].....	22
6.4	MONITOR VALVE GEARBOX [D].....	23
6.5	SIDE B OPTIONS [E].....	24
6.6	PORTS C1 AND C2 OPTIONS [F].....	25
7.0	FM APPROVAL (FACTORY MUTUAL)	27
8.0	MAINTENANCE AND REPAIRS	27
8.1	MAIN VALVE CRANKSHAFT OVERRIDE AND REPLACEMENT.....	27
8.2	MONITOR VALVE GEARBOX DIAGNOSIS AND REPLACEMENT	28
8.3	VALVE SEAT REPLACEMENT	29
9.0	PRESSURE LOSS.....	30
10.0	ANSWERS TO YOUR QUESTIONS.....	32
11.0	WARRANTY.....	32

▲ **DANGER**

PERSONAL RESPONSIBILITY CODE

The member companies of FEMSA that provide emergency response equipment and services want responders to know and understand the following:





1. Firefighting and Emergency Response are inherently dangerous activities requiring proper training in their hazards and the use of extreme caution at all times.
2. It is your responsibility to read and understand any user's instructions, including purpose and limitations, provided with any piece of equipment you may be called upon to use.
3. It is your responsibility to know that you have been properly trained in Firefighting and /or Emergency Response and in the use, precautions, and care of any equipment you may be called upon to use.
4. It is your responsibility to be in proper physical condition and to maintain the personal skill level required to operate any equipment you may be called upon to use.
5. It is your responsibility to know that your equipment is in operable condition and has been maintained in accordance with the manufacturer's instructions.
6. Failure to follow these guidelines may result in death, burns or other severe injury.



Fire and Emergency Manufacturers and Service Association
P.O. Box 147, Lynnfield, MA 01940 • www.FEMSA.org











1.0 MEANING OF SAFETY SIGNAL WORDS

A safety related message is identified by a safety alert symbol and a signal word to indicate the level of risk involved with a particular hazard. Per ANSI standard Z535.6-2011, the definitions of the four signal words are as follows:

	DANGER indicates a hazardous situation which, if not avoided, will result in death or serious injury.
	WARNING indicates a hazardous situation which, if not avoided, could result in death or serious injury.
	CAUTION indicates a potentially hazardous situation which, if not avoided, could result in minor or moderate injury.
	NOTICE is used to address practices not related to physical injury.

2.0 SAFETY

The operation of this monitor can be dangerous. The following must be observed at all times.

	WARNING Injury or death may occur by attempting to use a damaged Hydrant Under Monitor. Before use inspect it for damage resulting from: <ul style="list-style-type: none">• Exposure to temperatures in excess of 160 degrees F• Missing parts, physical abuse, exposure to severe chemicals• Failure to drain standpipe followed by exposure to freezing conditions. See section 5.3 DRAINING RESIDUAL WATER for instructions.
	WARNING This equipment is intended for use by trained personnel for fire fighting. Its use for other purposes may involve hazards not addressed by this manual. Seek appropriate guidance and training to reduce risk of injury
	WARNING Injury or death can result from burst hoses and fittings. Risk can be minimized by the proper care and use of hose and appliances per NFPA 1962.
	WARNING Kinks in supply hose may reduce water flow and cause injury or death to persons dependent on water flow. Avoid tight bends to minimize risk of hose line kinks.
	WARNING Quick changes in valve position can cause high pressure spikes due to water hammer and may result in damaged equipment which could lead to injury or death. Open and close the valve slowly to avoid water hammer.
	WARNING The Hydrant Under Monitor may be damaged if frozen while containing significant amounts of water. Such damage may be difficult to detect visually and can lead to possible injury or death. Any time the Hydrant Under Monitor is subject to possible damage due to freezing, it must be hydrostatically tested by qualified personnel before being considered safe for use.
	CAUTION Maximum operating pressure 300 PSI (21 bar). Exceeding 300 psi (21 bar) on either side of the valve may damage valve and could cause injury.
	CAUTION Hoses and monitors must be properly connected. Mismatched or damaged connectors may cause leaking or uncoupling under pressure and could cause injury.
	CAUTION Any alterations to the valve and its markings could diminish safety and constitutes a misuse of this product.
	CAUTION Dissimilar metals coupled together can cause galvanic corrosion that can result in the inability to unscrew threads and complete loss of thread engagement over time. Use of flange isolation kits and anti-corrosive lubricant such as Dow Corning 112 Silicone Grease is recommended to prevent galvanic corrosion
	CAUTION Use with salt water is permissible provided the monitor is thoroughly cleaned with fresh water after each use. The service life of the monitor may be shortened due to the effects of corrosion and is not covered under warranty.

3.0 GENERAL INFORMATION

The Hydrant Under Monitor (HUM) is a robust, low friction loss valve designed to supply a monitor and up to two large diameter hose (LDH) ports. Two concentric slow-close half ball valves allow the monitor to be operated either independently or simultaneously with the LDH ports. The main shutoff valve has a 5.25" waterway, located immediately above the 6" ANSI 150 inlet flange. When the monitor valve above is also open, flow to the monitor from the standpipe is completely unobstructed for the lowest possible friction loss. Each valve control is clearly marked with separate color-coded position indicator flags that are retro-reflective for visibility in all light conditions. The cast A356-T6 aluminum valve body and all structural 6061-T6 aluminum components are hard anodized, and the inlet flange and valve body are powder coated inside and out for additional resistance to galvanic corrosion.

Several options are available for monitor connection, as described in section 3.5.4. For further versatility, the ZC-series Booster or ZD-series Oscillator (both sold separately) can be installed between the HUM and monitor to allow pressure boosting capability or water-driven oscillation of the monitor.

The two LDH ports C1 and C2 can be configured with a Storz coupling, a male threaded nipple, or a gated wye. Connection sizes from 1.5" up to 6.0" are available. All LDH connections are supplied with a pressure cap, and port C2 can also be configured with a blind plug if only one hose connection is needed. LDH port options are described in sections 3.5.5 through 3.5.7.

All models are equipped with an external automatic drain valve, as well as an automatic drain valve that is integrated within the monitor valve half ball. These two drain valves fully evacuate the monitor and valve body after each use when pressure in the HUM drops below 5 psi, thus minimizing susceptibility to damage from corrosion and freezing water. An optional third automatic drain valve that is integrated within the main shutoff half ball allows the standpipe to draw atmospheric air to facilitate draining, even while the half ball is closed. The automatic drain valve is described in further detail in sections 3.5.3 and 5.3.

3.1 SPECIFICATIONS

HYDRANT UNDER MONITOR SPECIFICATIONS	
NFPA 24, 2010 Edition Compliance *	Hydrant, Main Valve, and Monitor Valve
Main Valve Seat Diameter	5.25" (133 mm)
Main Valve Control	30:1 reduction worm gearbox
Monitor Valve Seat Diameter	3.65" (93 mm)
Monitor Valve Control	34:1 reduction parallel shaft gearbox
C1 LDH Port Diameter	5.25" (133 mm)
C2 LDH Port Diameter	3.50" (89 mm)
Safe Operating Range for Side B Monitor Outlet: Maximum flow rates at specified nozzle inlet pressures are based on 1500 lb (680 kg) maximum nozzle reaction force at 20" (508mm) monitor height. Read section 4.2 for monitor installation requirements.	2500 gpm @ 130 psi (9500 l/min @ 9 bar) 2000 gpm @ 200 psi (8000 l/min @ 14 bar) 1600 gpm @ 300 psi (6000 l/min @ 21 bar)
Rated Operating Pressure for all ports (either closed or flowing)	300 psi (21 bar)
Hydrostatic Proof Test	1200 psi (83 bar)**
Temperature Rating ***	-25° to 135°F (-32° to 57°C)
<p>* NFPA 24 compliance requires removal of knobs from crank handles to ensure greater than 5 seconds to close from fully open position. Time to close or open the valves is entirely dependent on the speed at which the user operates the crank handles. After removing the knobs, the user's hands must be repositioned at least 8 times to transition between the fully open and closed positions, which cannot be completed in less than 5 seconds.</p> <p>**Do not exceed the rated operating pressure of 300 psi (21 bar). The hydrostatic proof test is performed on a sample valve to ensure it does not visibly rupture, crack or permanently distort at 4 times the rated operating pressure. The purpose of the proof test is to be confident the valve design may be safely operated at the rated operating pressure.</p> <p>*** For temperatures below 32°F (0°C), standpipe must be drained after use to avoid damage.</p>	

3.2 CORROSION RESISTANCE

All valve bodies are hard anodized aluminum which is powder coated inside and out to help prevent corrosion. Galvanic corrosion due to dissimilar metals can be minimized by using flange isolation kits and an anti-corrosive lubricant such as Dow Corning 112 Silicone Grease. Where practical, the standpipe should be drained while not in use to eliminate a path of conduction. Do not install brass fittings, discharge fittings or monitors onto this valve.

3.3 USE WITH SALT WATER

Use with salt water is permissible provided valve is thoroughly cleaned with fresh water after each use. The service life of the valve may be shortened due to the effects of corrosion and is not covered under warranty.

3.4 PARTS IDENTIFICATION AND INTENDED ORIENTATION

Figures 3.4.1 and 3.4.2 identify the typical functional components of the Hydrant Under Monitor (HUM). The HUM is intended to be installed in the orientation shown, with the inlet flange facing towards the earth below. This orientation allows the monitor and HUM to fully drain after use as described in section 5.3 DRAINING RESIDUAL WATER.

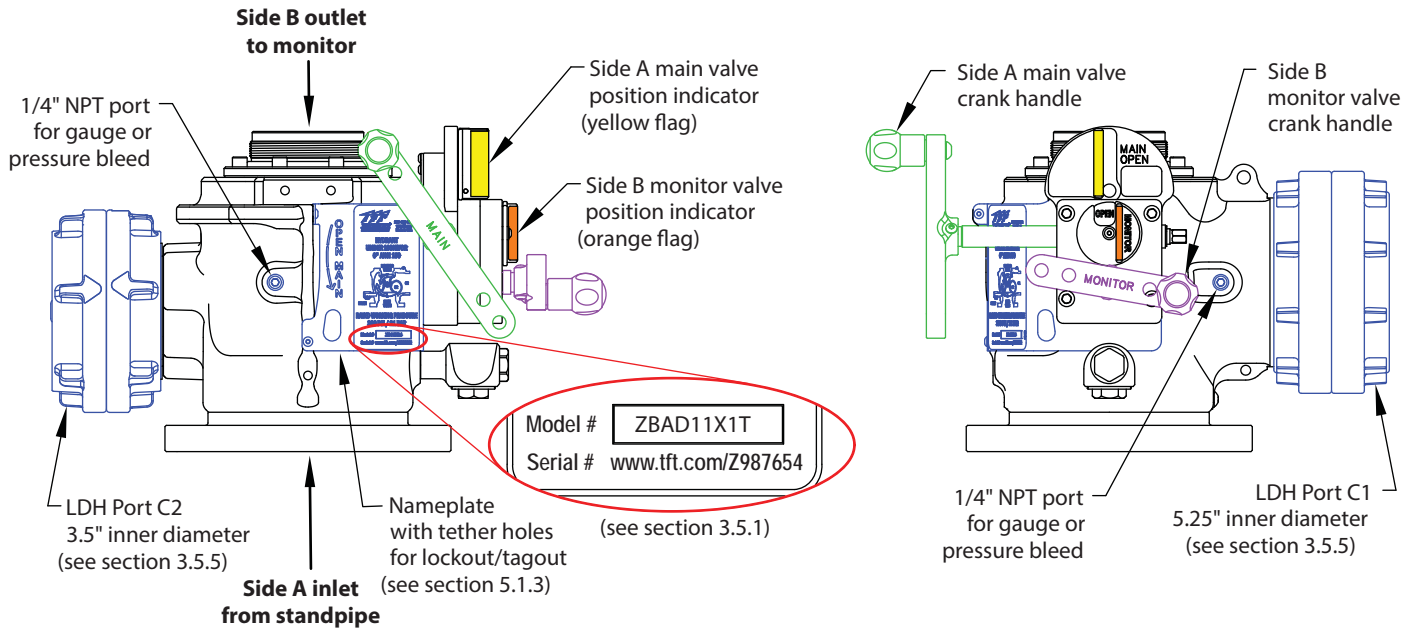
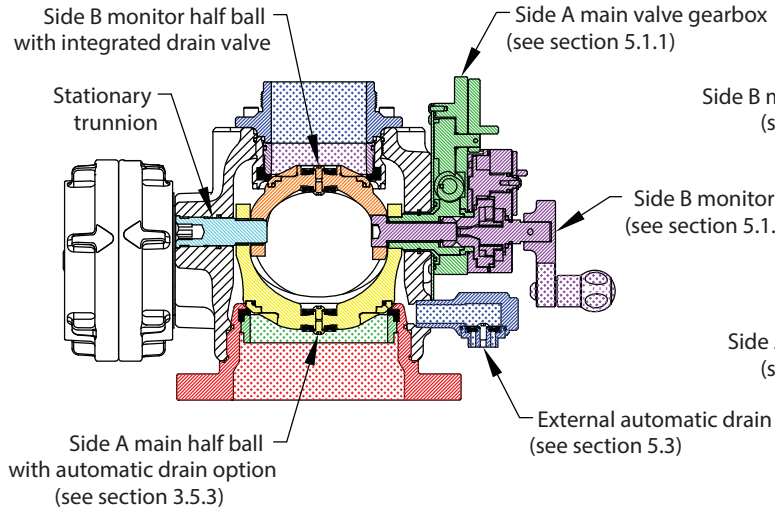

Figure 3.4.1: External views for parts identification

CROSS-SECTION VIEW THROUGH HALF BALL TRUNNIONS WITH BOTH VALVES CLOSED



CROSS-SECTION VIEW THROUGH LDH PORT C1 WITH BOTH VALVES OPEN

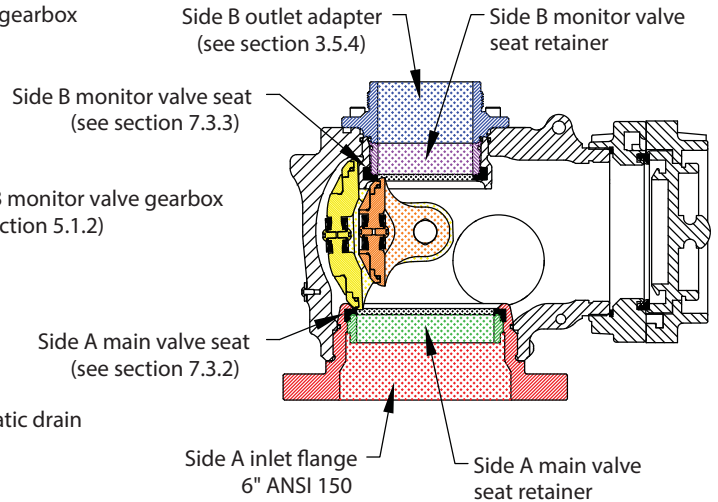

Figure 3.4.2: Cross-section views for parts identification

3.5 OPTIONS, DIMENSIONS AND WEIGHTS

Several options are available for valve control, monitor mounting, and the two LDH ports. Each option is described in sections 3.5.3 through 3.5.7. The dimensions and approximate weights of the individual options can be added together to calculate the overall size and weight of the HUM with the desired options installed. All weights include supplied caps and adapters.

3.5.1 MODEL NUMBERS AND SERIAL NUMBERS

Model numbers can be specified by combining 9 characters in the sequence shown below. The unique characters for each component option are presented in sections 3.5.3 through 3.5.7, along with the corresponding weights and dimensions. The model number and unique serial number of each HUM are located at the bottom of the nameplate, as shown in figure 3.4. The serial number also serves as an internet address to provide additional information about the product.

MODEL NUMBER SEQUENCE										
Character Position	1	2	3	4	5	6	7	8	9	
Component	ZB (same prefix for all models)		A RESERVED (same for all models)		DRAIN OPTION	SIDE B (monitor)	LDH PORT C1 (5.25" I.D.)		LDH PORT C2 (3.5" I.D.)	
							STYLE	SIZE	STYLE	SIZE

Example model #:	ZBAD31X8J	Character Sequence	Weight (lb)
Main Valve Body:	Same for all models	prefix ZBA same for all models	57.5
Drain Option:	Main Half Ball with Automatic Drain	Character "D" in position 4	+ 0
Side B (monitor):	4" ANSI 150 / DN 100 PN16 Flange	Character "3" in position 5	+ 6.5
Port C1 Style:	Storz	Character "1" in position 6	
Port C1 Size:	6.0" (150 mm)	Character "X" in position 7	+ 10.9
Port C2 Style:	2.5" Gated Wye	Character "8" in position 8	
Port C2 Size:	2.5"	Character "J" in position 9	+ 11.4
Net Weight:	85.4 lb (38.7 kg)		= 85.4

3.5.2 MAIN VALVE BODY

The main valve body is shared by all HUM models. It weighs 57.5 lb (26.1 kg), including the inlet flange, both half balls, the external drain valve, and all fasteners that are shared by every HUM model. The optional drain in the main valve half ball does not affect the weight of the valve. Dimensions are shown in figure 3.5.2 below.

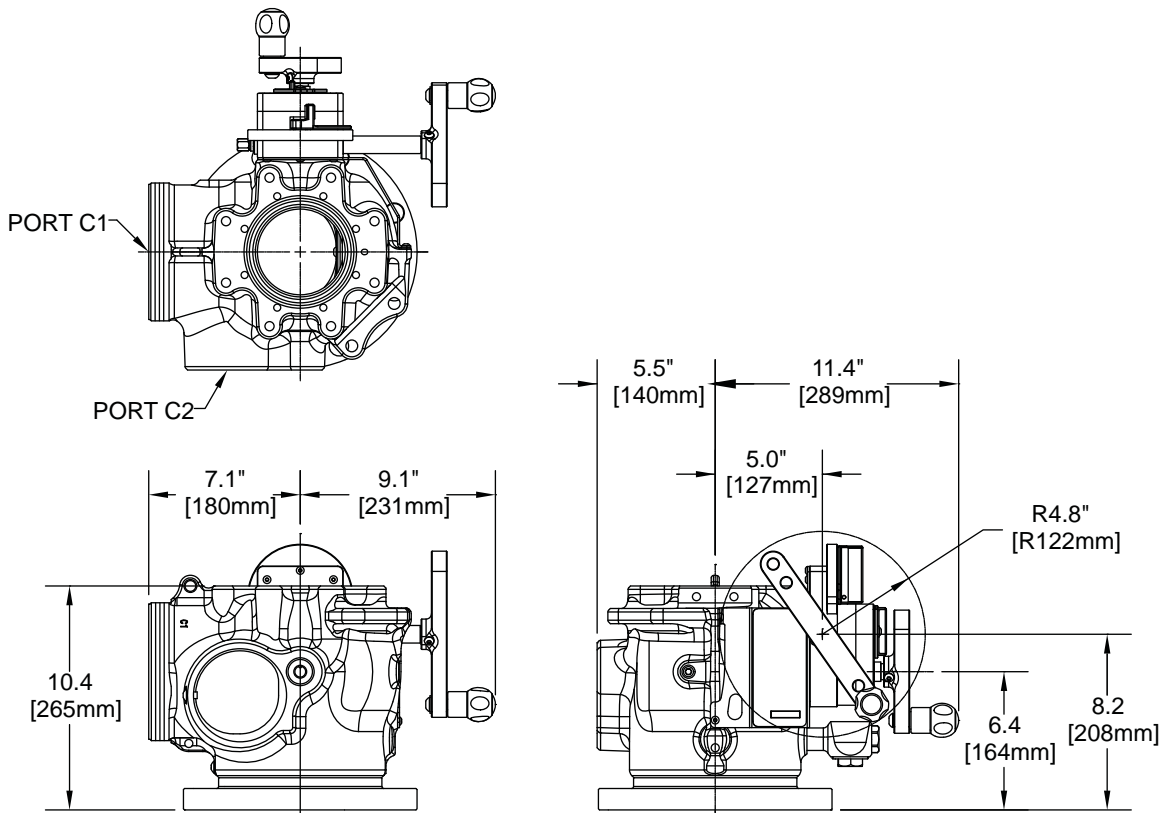

Figure 3.5.2: Main Valve Body Dimensions

3.5.3 INTERNAL DRAIN OPTION (character position 4)

All HUM models are equipped with an external automatic drain valve attached to a port directly above the valve seat, as well as a drain valve integrated within the monitor-control half ball (Side B). These drain valves allow the monitor and valve body to drain fully after the half ball is closed, thus minimizing susceptibility to damage from corrosion and freezing water. See section 5.3 DRAINING RESIDUAL WATER for further details.

The side A main half ball valve used for monitor shutoff can be specified either with (option D) or without (option Z) an integrated automatic drain valve, as shown in figure 3.5.3. This drain allows the standpipe to draw atmospheric air to facilitate draining, even while the main half ball is closed. It is beneficial in applications where the standpipe will typically be drained following use, especially where freezing conditions are a concern.

This drain valve is able to seal the full rated pressure from either side of the half ball and does not affect the weight of the assembly.

INTERNAL DRAIN OPTION (character position 4)	CHARACTER	PART NUMBER	WEIGHT
MAIN HALF BALL WITH AUTOMATIC DRAIN	D	A1089P.3	included in main valve weight
MAIN HALF BALL WITHOUT AUTOMATIC DRAIN	Z	A1088P.1	included in main valve weight

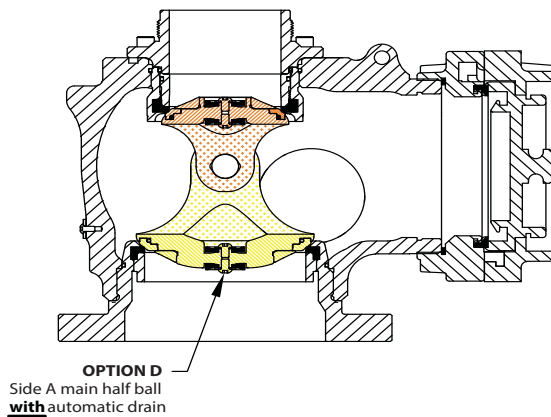

DRY Standpipe Systems

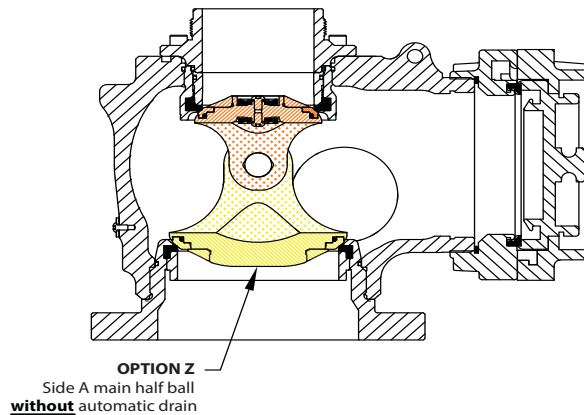

WET Standpipe Systems

Figure 3.5.3: Internal Drain Option

3.5.4 OPTIONS FOR SIDE B OUTLET TO MONITOR (character position 5)

The side B outlet is intended to be connected directly to the inlet of a deluge monitor. The industry standard 4" ANSI 150 and DN 100 PN16 bolt patterns are available combined into a single flange (options 3 and 4). The other options allow unique capabilities when combined with Task Force Tips monitors, such as direct connection for reduced height and cost (options 1 and 2), a secure quick connection (options Q and T), pressure boosting capability (sold separately for use with option 0), or water-driven oscillation of the monitor (also sold separately for use with option 0). The dimensions below indicate the distance each option protrudes from the main valve body. Portions of the graphics that overlap with the main valve body are excluded from these dimensions.

SIDE B OPTIONS (character position 5)	CHARACTER	PART NUMBER	WEIGHT (LB)	WEIGHT (KG)
NO SIDE B ADAPTER INSTALLED (not shown; for use with ZC-series Booster or ZD-series Oscillator)	0	N/A	N/A	N/A
CODE-RPM DIRECT CONNECTION, STRAIGHT	1	A1026	1.8	0.82
CODE-RPM DIRECT CONNECTION, ANGLED 22.5°	2	A1040	2.8	1.27
4" ANSI 150 / DN 100 PN16 FLANGE, STRAIGHT	3	A1039.1	6.5	2.95
4" ANSI 150 / DN 100 PN16 FLANGE, ANGLED 22.5°	4	A1039.2	7.5	3.40
QUICK CONNECT - 4.5"NHM (for Monsoon, Typhoon, Hurricane & 90° Elbow)	Q	Y4484	2.3	1.04
QUICK CONNECT - 2.5"NHM (for Tornado)	T	Y2432A.1	2.1	

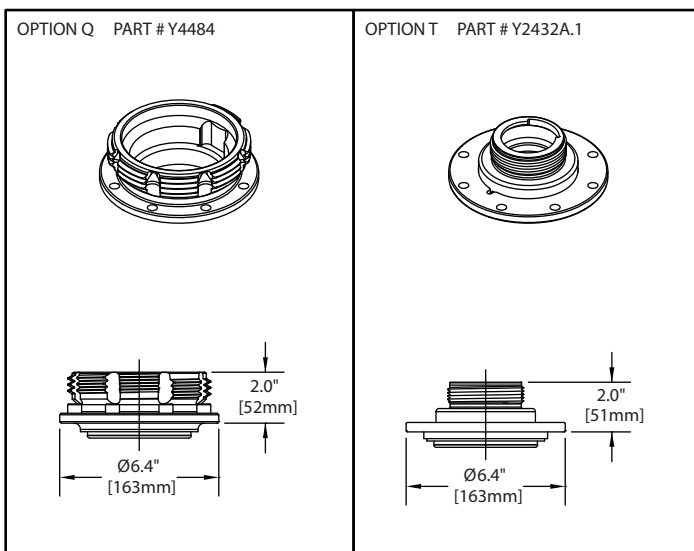
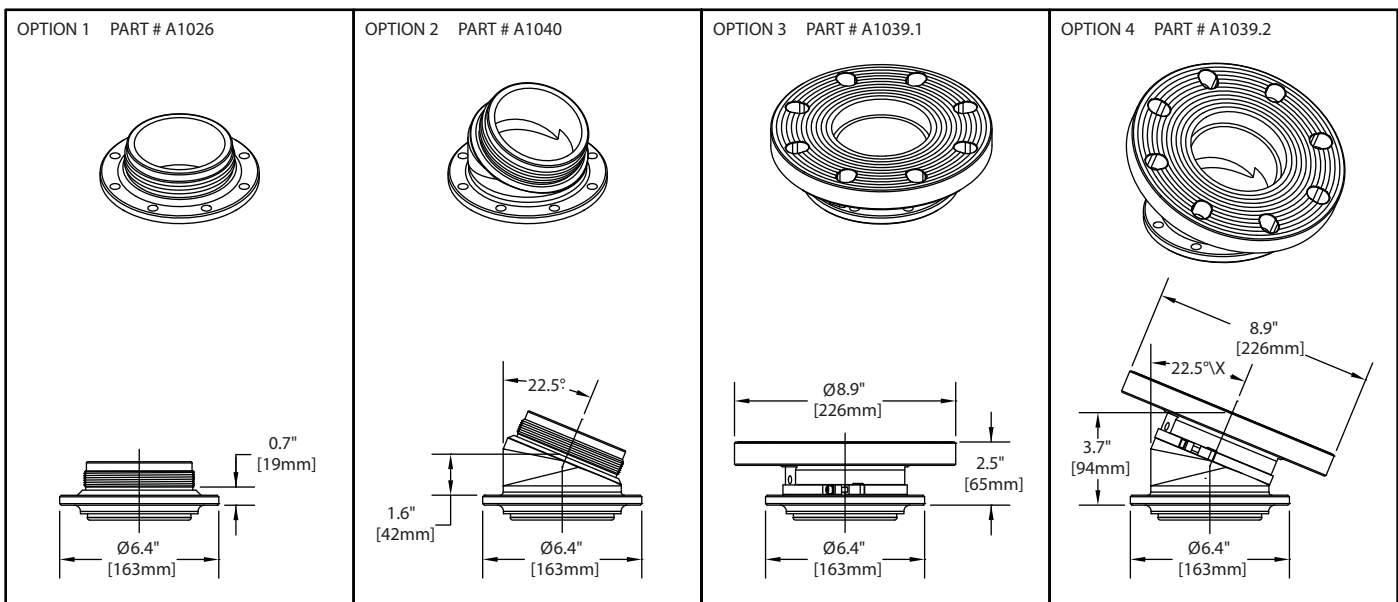

3.5.5 LARGE DIAMETER HOSE PORT OPTIONS (see sections 3.5.6 and 3.5.7 for dimensions)

The two LDH ports C1 and C2 can each be configured with a Storz coupling, a male threaded spout, or a gated wye. Hose connection size options range from 1.5" to 6" for the larger Port C1 and from 1.5" to 5" for the smaller Port C2. Each LDH connection is supplied with a pressure cap. If only one hose connection is needed, port C2 can be configured with a blind plug. When specifying port options, the 1st character is the connection type and the 2nd character is the connection size.

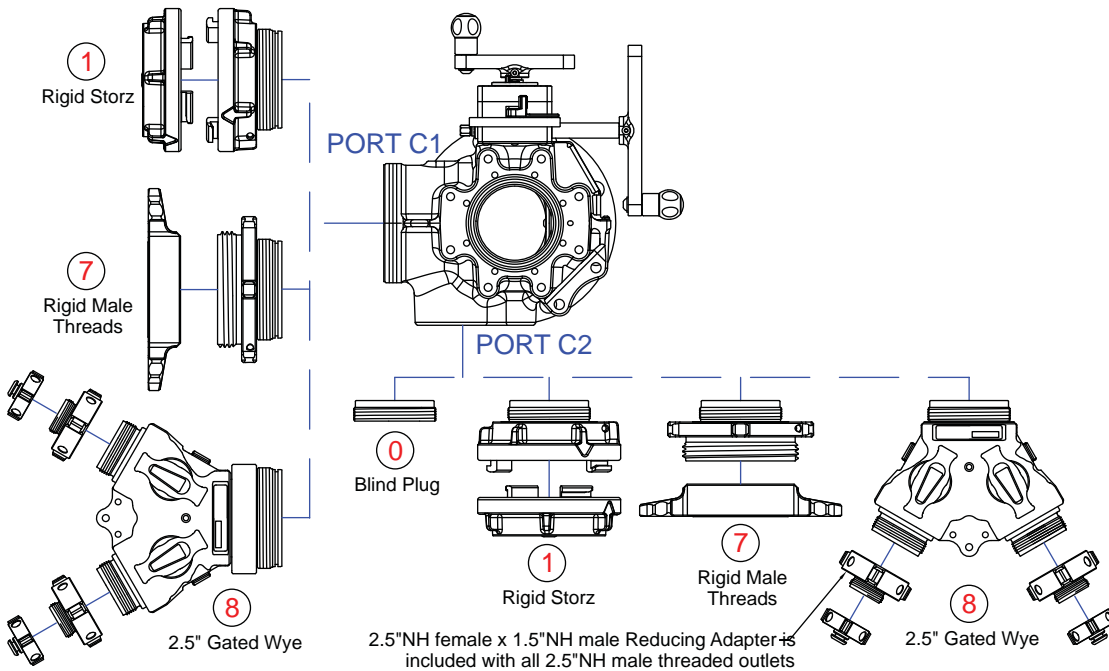

PORT C1 OPTIONS (character positions 6 and 7)	CHARACTERS	SUBASSEMBLY #	WEIGHT (LB)	WEIGHT (KG)
4.0" Storz for port C1 only; includes pressure cap	1P	ZBC1-1P	6.5	2.94
5.0" Storz for port C1 only; includes pressure cap	1T	ZBC1-1T	7.3	3.30
6.0" Storz for port C1 only; includes pressure cap	1X	ZBC1-1X	10.0	4.53
2.5" NH male thread for port C1 only; includes 2.5" NH female x 1.5" NH male reducer and 1.5" cap	7J	ZBC1-7J	4.3	1.95
3.0" NH male thread for port C1 only; includes cap	7L	ZBC1-7L	6.9	3.14
3.5" NH male thread for port C1 only; includes cap	7N	ZBC1-7N	6.5	2.95
4.0" NH male thread for port C1 only; includes cap	7P	ZBC1-7P	5.5	2.51
4.5" NH male thread for port C1 only; includes cap	7R	ZBC1-7R	6.6	2.98
5.0" NH male thread for port C1 only; includes cap	7T	ZBC1-7T	6.6	3.00
6.0" NH male thread for port C1 only; includes cap	7X	ZBC1-7X	7.9	3.57
2.5" NH male gated wye for port C1 only; includes 2.5" NH female x 1.5" NH male reducer and 1.5" cap	8J	ZBC1-8J	13.2	5.99

PORT C2 OPTIONS (character positions 8 and 9)	CHARACTERS	SUBASSEMBLY #	WEIGHT (LB)	WEIGHT (KG)
Blind Plug for port C2 only	00	ZBC2-00	1.0	0.44
4.0" Storz for port C2 only; includes pressure cap	1P	ZBC2-1P	4.6	2.11
5.0" Storz for port C2 only; includes pressure cap	1T	ZBC2-1T	7.3	3.30
2.5" NH male thread for port C2 only; includes 2.5" NH female x 1.5" NH male reducer and 1.5" cap	7J	ZBC2-7J	2.5	1.12
3.0" NH male thread for port C2 only; includes cap	7L	ZBC2-7L	5.1	2.31
3.5" NH male thread for port C2 only; includes cap	7N	ZBC2-7N	4.7	2.12
4.0" NH male thread for port C2 only; includes cap	7P	ZBC2-7P	5.5	2.50
4.5" NH male thread for port C2 only; includes cap	7R	ZBC2-7R	6.6	2.97
5.0" NH male thread for port C2 only; includes cap	7T	ZBC2-7T	6.6	2.99
2.5" NH male gated wye for port C2 only; includes 2.5" NH female x 1.5" NH male reducer and 1.5" cap	8J	ZBC2-8J	11.4	5.18

3.5.6 DIMENSIONS OF PORT C1 OPTIONS (character positions 6 and 7)

NOTES:

1. The dimensions below indicate the distance each option protrudes from the main valve body. Portions of the graphics that overlap with the main valve body are excluded from these dimensions.
2. For options that include removable caps and reducing adapters, dimensions are shown for the overall assembled condition as well as each component individually.

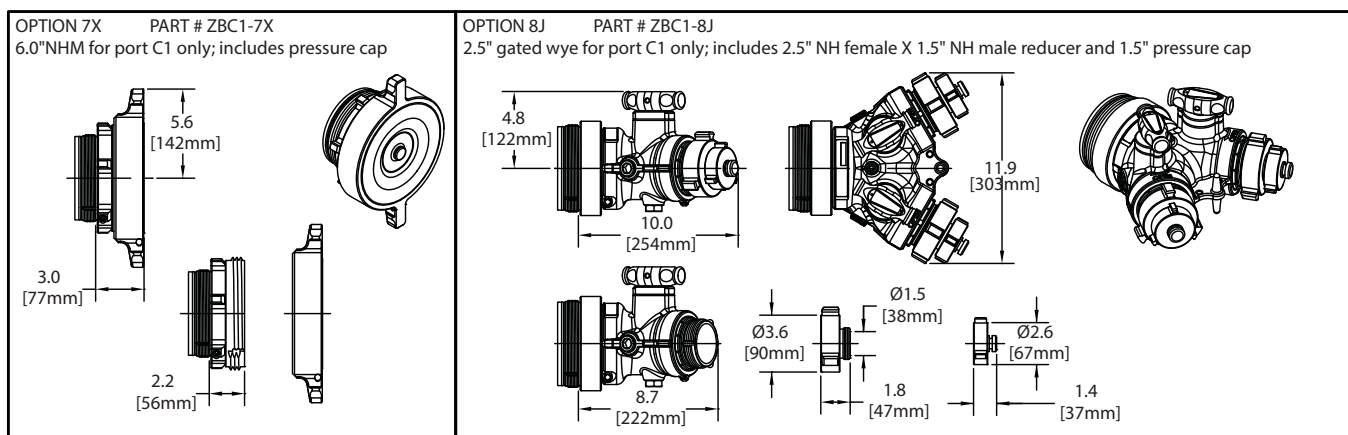
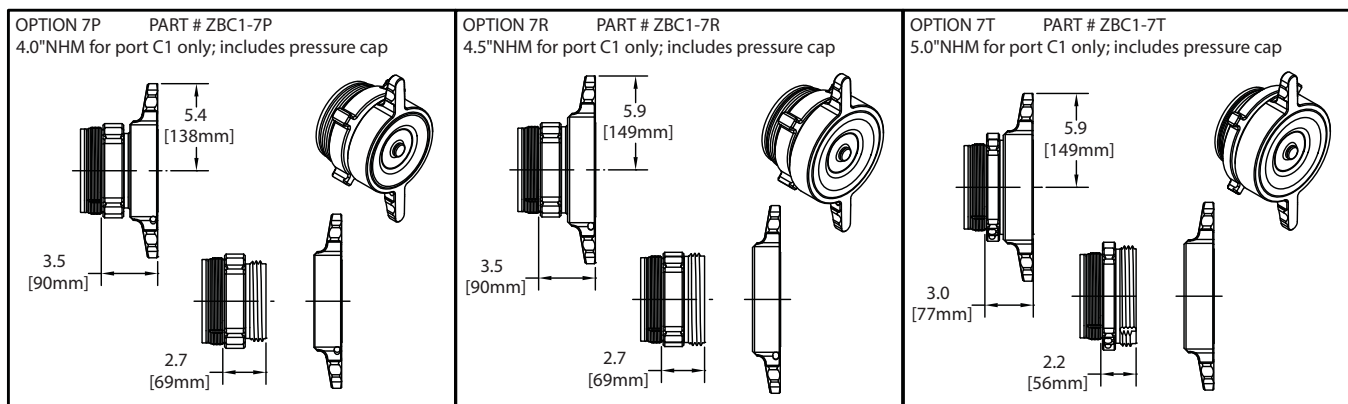
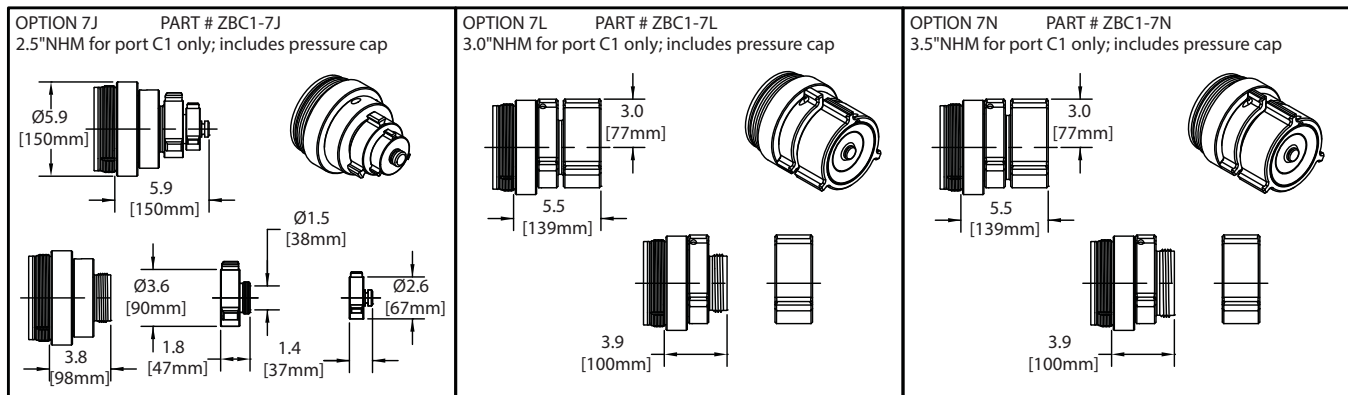
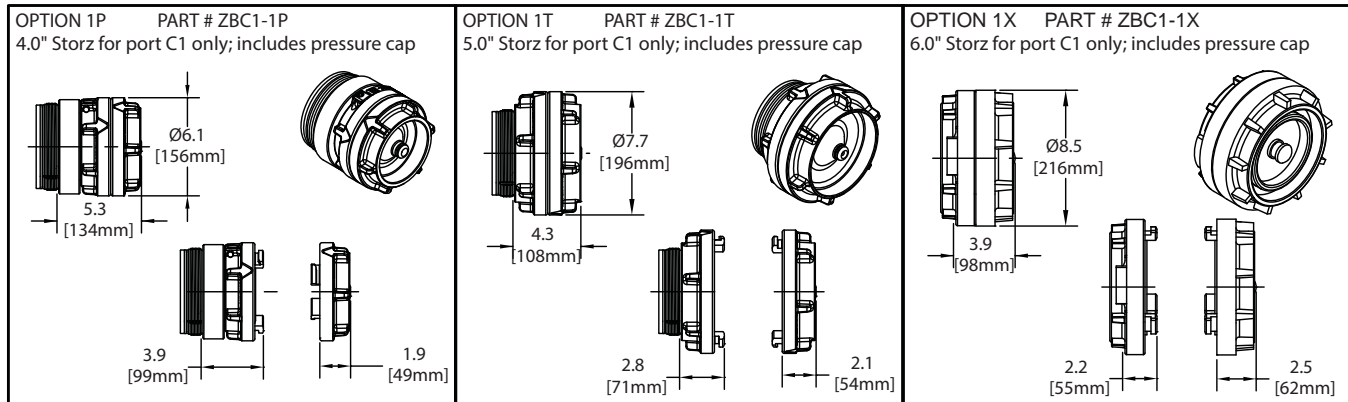

3.5.7 DIMENSIONS OF PORT C2 OPTIONS (character positions 8 and 9)

NOTES:

1. The dimensions below indicate the distance each option protrudes from the main valve body. Portions of the graphics that overlap with the main valve body are excluded from these dimensions.
2. For options that include removable caps and reducing adapters, dimensions are shown for the overall assembled condition as well as each component individually.

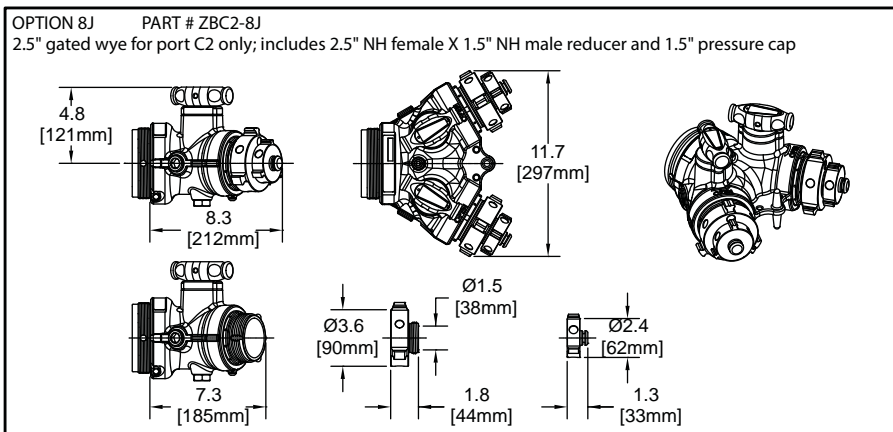
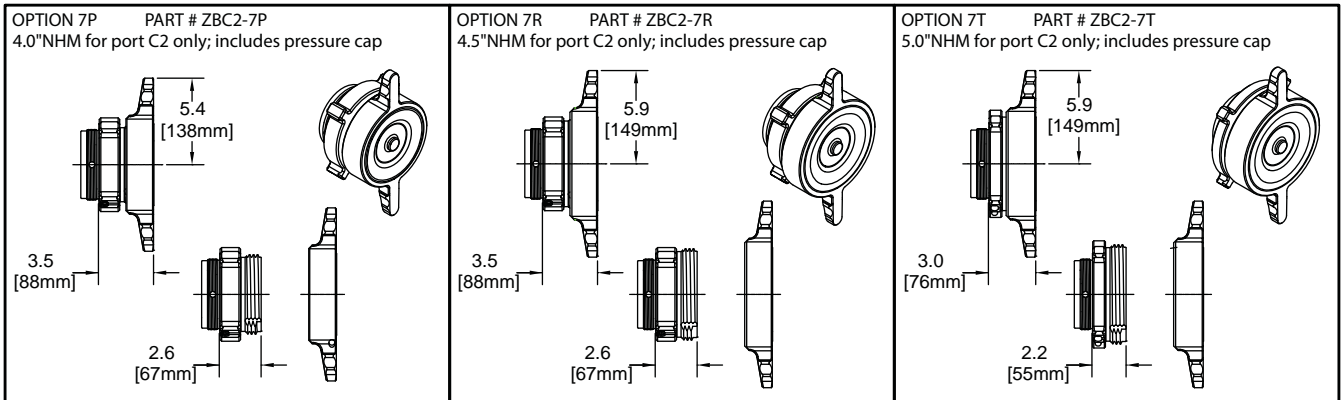
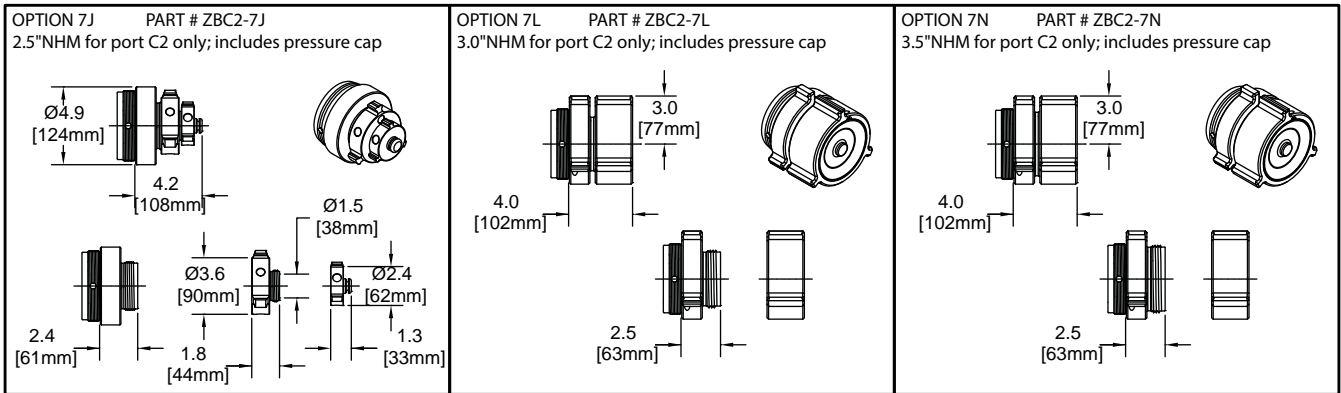
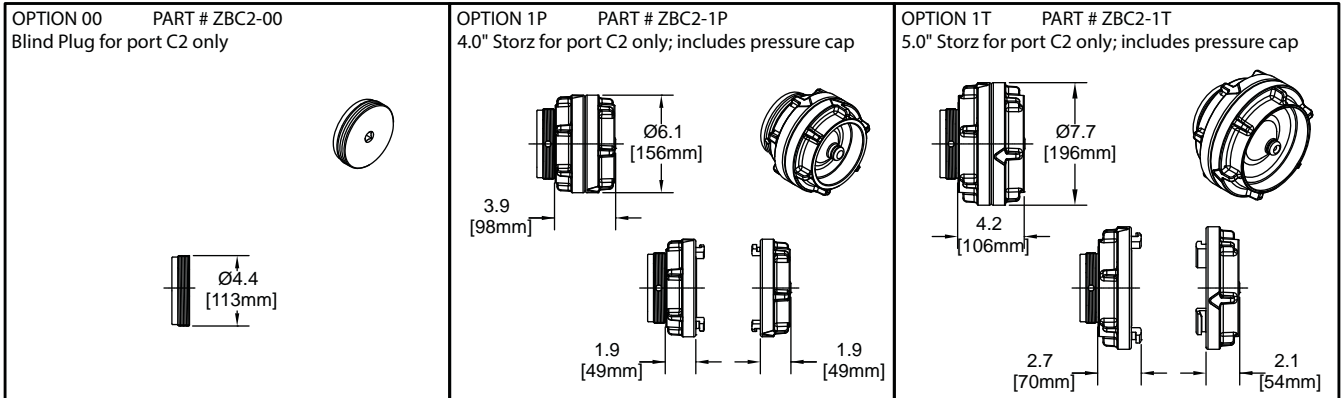

4.0 INSTALLATION

4.1 STRUCTURAL REQUIREMENTS

⚠️ WARNING

Injury can result from an inadequately supported monitor. The structure to which the Hydrant Under Monitor is mounted must be capable of withstanding the internal pressure of the monitor as well as shear and bending forces due to nozzle reaction. Nozzle reaction can be as high as 1500 lbs (680 kg) (equivalent to 2000 gpm at 200 psi or 1600 gpm at 300 psi). Flanges and pipe made from plastic are inadequate for valve mounting and must not be used. Verify that mobile equipment is constructed and setup for stable and safe operation under the influence of tipping and sliding hazards.

4.2 FLANGE INSTALLATION

For flanged connections, the use of flat flanges without raised faces is recommended. Use a ring gasket as defined in ASME 16.21 or ISO 7483. Hand tighten all nuts until snug against the flanges, then tighten in the alternating sequence shown in figure 4.2. Tighten sequentially each bolt or stud three times with 30%, then 60%, and finally 100% of the specified torque.

For the Side A inlet with a 6" ANSI 150 flange and 3/4-10 bolts or studs, tighten to 134-141 ft-lb (182-191 Newton-meters).

For 4" ANSI 150 flanges with 5/8-11 bolts or studs, tighten to 76-80 ft-lb (100-110 Newton-Meters).

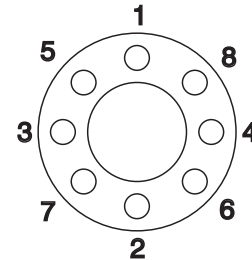

Figure 4.2 Flange Bolt Tightening Sequence

4.3 MONITOR INSTALLATION AND COMPATIBILITY

A series of TFT Industrial Monitors has been created specifically for use with the HUM, Booster and Industrial Valve Under Monitor. These monitors are specified by adding the -Z suffix to the desired model of TFT Monsoon, Typhoon or Hurricane (e.g. Y5-DP1A-Z). Models with -Z suffix are the only monitors verified to be compatible with the HUM. All TFT Industrial Monitors feature American Red powder coating and monitor base heights chosen to work well with the HUM and IVUM. In addition, all Industrial Monsoons and Typhoons include aluminum crank handles on each worm-drive control.

⚠️ WARNING

This monitor height limit applies whether or not a ZC-series Booster or ZD-series Oscillator is installed between the HUM and the Monitor. Figure 4.3 illustrates acceptable monitor height. Within the specified operating range, the Hydrant Under Monitor is designed to withstand nozzle reaction forces from monitors measuring up to 20" (508 mm) from the bottom edge of the monitor inlet (flange or female thread) to the center line of the monitor outlet. Injury can result from the reaction forces of monitor outlets located more than 20" (508 mm) from the inlet.

⚠️ WARNING

Do not use the Hydrant Under Monitor with monitor extension pipes such as the Task Force Tips Extend-A-Gun, Akron 3406 and Elkhart Extender. Injury and equipment damage can result from the reaction forces from this combination of products. This exclusion does not apply to the ZC-series Booster and ZD-series Oscillator, which were specifically designed for safe use with the HUM.

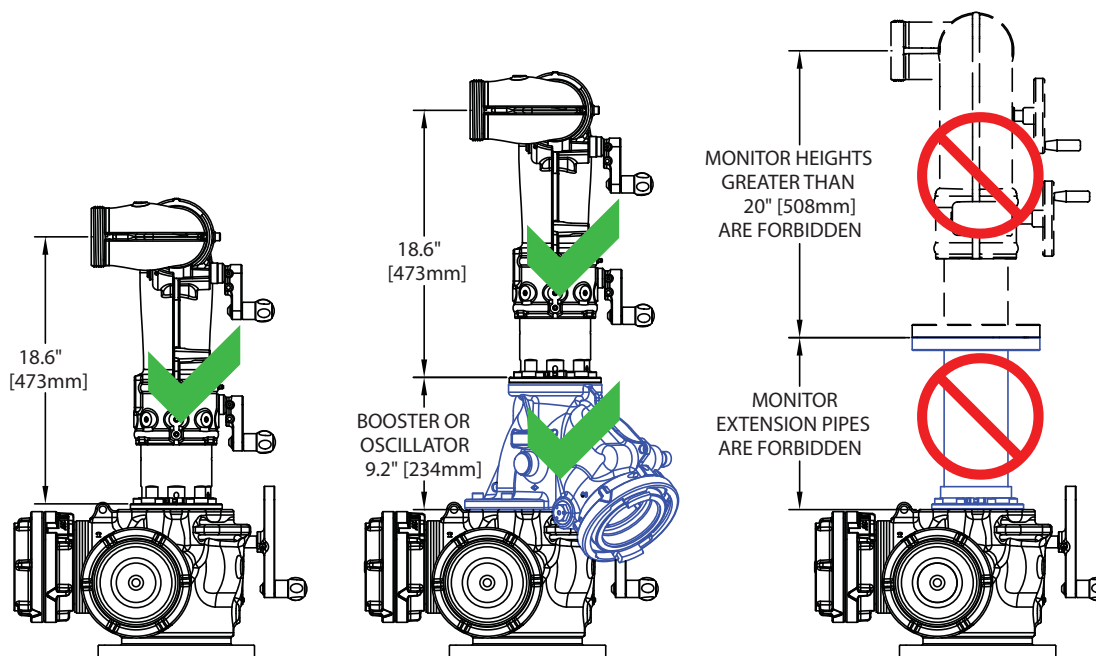

Figure 4.3: Acceptable Monitor Height

4.3.1 MONITOR INSTALLATION USING CODE-RPM DIRECT CONNECTION (Side B options 1 and 2)

Refer to figure 4.3.1

1. Assemble Monitor Base Clamp loosely per instructions from monitor manual. Place clamps over HUM outlet, in an orientation that allows access to tighten the Clamp screws.
2. Screw monitor onto HUM until threaded joint bottoms out.
 - **CAUTION:** Make sure the Clamp is not tight enough to prevent the monitor Base from bottoming out. The monitor will leak if it does not bottom out in this step.
 - Do not use pipe dope or Loctite on the monitor base threads. These threads are sealed with the O-ring shown, which is installed in the monitor at the factory. The use of thread locking compounds will make removal difficult.
3. Unscrew monitor until the "Straight Ahead Reference Mark" is facing the desired direction.
 - Monitor may be unscrewed up to one full turn from the bottomed out position.
 - **CAUTION:** Monitor will leak if unthreaded more than one full rotation from bottomed-out condition.
4. Ensure that Clamp assembly does not interfere with RC monitor Power/Com Cable (if applicable). Reposition Clamp if needed.
5. Tighten each Screw gradually until both are finger tight with approximately equal spacing between opposite ends of Clamp.
6. Carefully tighten each Screw one additional turn using a 5/32 hex wrench by alternating to the opposite Screw in half turn increments. **CAUTION:** Over tightening the Screws will damage Screws and Clamp.

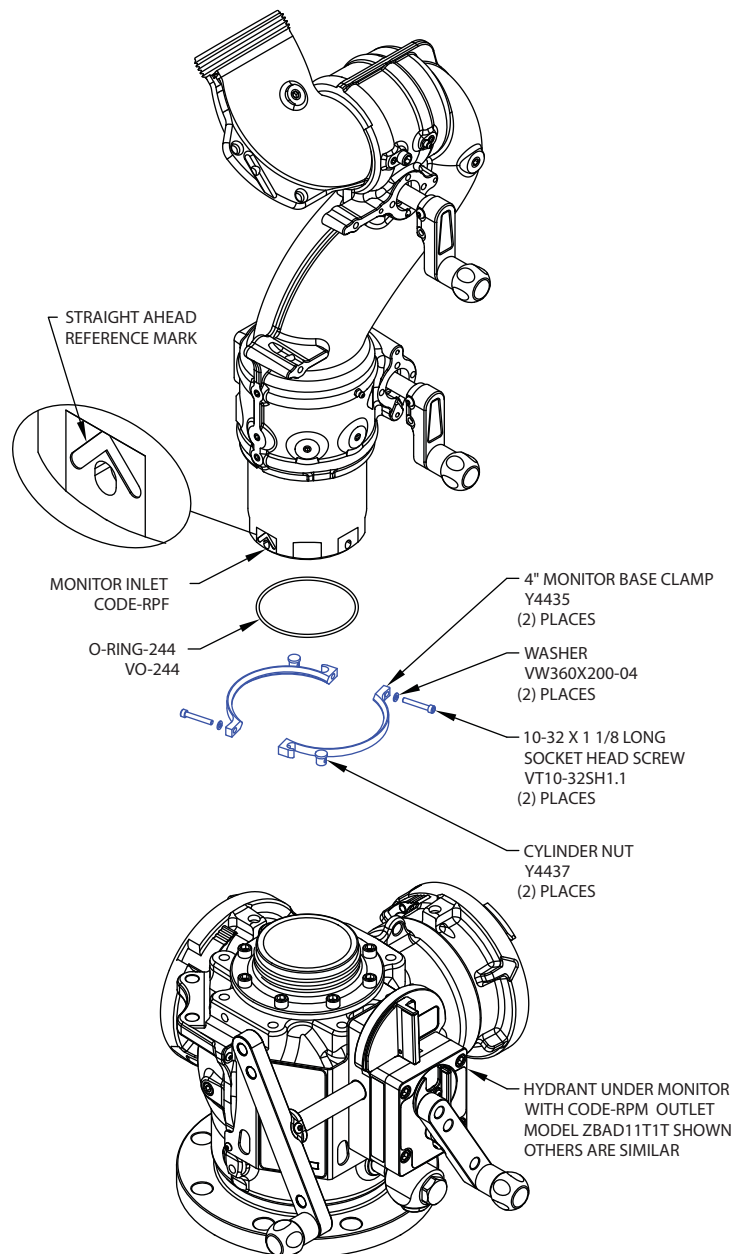

Figure 4.3.1: CODE-RPM Direct Connection

4.3.2 MONITOR INSTALLATION USING 4" ANSI 150 FLANGE (Side B options 3 and 4)

Refer to figure 4.3.2.

1. Install a ring gasket between the monitor and HUM.
2. Hand tighten all nuts until snug against the flanges, then tighten in an alternating sequence as shown.
3. For 4" ANSI 150 flanges with 5/8-11 bolts or studs, tighten to 76-80 ft-lb (100-110 Newton-Meters). Tighten sequentially each bolt or stud three times with 30%, then 60%, and finally 100% of the specified torque.

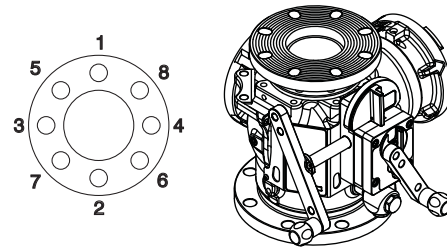

Figure 4.3.2: 4" ANSI 150 Monitor Installation

4.3.3 ZC-SERIES BOOSTER OR ZD-SERIES OSCILLATOR INSTALLATION (Side B option 0)

Refer to figure 4.3.3

1. Install the o-ring onto the barb that protrudes from the bottom flange of the Booster or Oscillator. Apply silicone grease over the o-ring.
2. Align the Booster or Oscillator with the HUM as shown. Apply Loctite 242 (blue) thread locker to (8) 1/2-13 x 1.5" screws, then insert and tighten the screws until the heads are bottomed out. Bolt numbers 3 and 5 are inserted up thru the HUM, then into the Booster or Oscillator. The other six bolts are inserted through the top of the Booster or Oscillator.
3. Continue tightening screws according to the alternating sequence indicated by bolt numbers 1 through 8 until the o-ring is compressed into the HUM and the flange faces contact each other. Tighten alternating screws to 33 - 37 ft-lb (45 - 50 N-m) sequentially three times at 30%, then 60%, and finally 100% of the specified torque.
4. The Side 'B' monitor connection options for the Booster and Oscillator use the same components as the Hydrant Under Monitor. Install monitor using the appropriate instructions from section 4.3 of this manual.

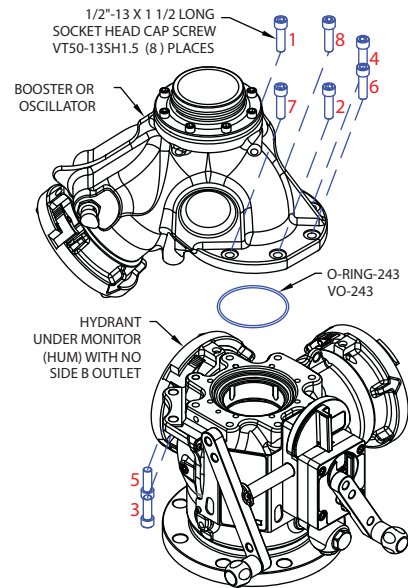

Figure 4.3.3: Booster or Oscillator Installation

4.3.4 MONITOR/ELBOW INSTALLATION USING QUICK CONNECT COUPLING (Side B options Q & T)

Refer to figure 4.3.4. HUMs with Side B options Q and T are supplied with the male threaded side of the quick connect installed. An HUM with side B option Q is shown with a 4.5"NH quick connect monitor. Side B option T for the 2.5"NH quick connect is similar, but only has one tongue and slot rather than two. The female coupling of the appropriate monitor or elbow can be installed using these instructions. For additional details, refer to documents LIY-250 for 4.5"NH quick connect and LIY-300 for Tornado with 2.5"NH inlet.

1. For female couplings with locking pins, hold pin out and push coupling up as far as it will go, then release the pin. This will hold the coupling out of the way while mounting the monitor on the HUM. For elbows or other devices that do not include a locking pin on the female coupling, omit this step.
2. Align tongue(s) of female inlet into notches within male threaded outlet. This feature is a rotational lock to prevent loosening of the coupling when the device is swiveled. Slide tongue(s) into slots(s) until the threads make contact.
3. Rotate coupling clockwise until threads engage on male threaded outlet, then release locking pin (if so equipped). Continue to rotate coupling until tight. Locking pin will ratchet across detents, but it is not necessary to over-tighten the coupling if locking pin ends up between detent positions. To prevent damage, do not use locking pin as a lever to tighten or loosen coupling.

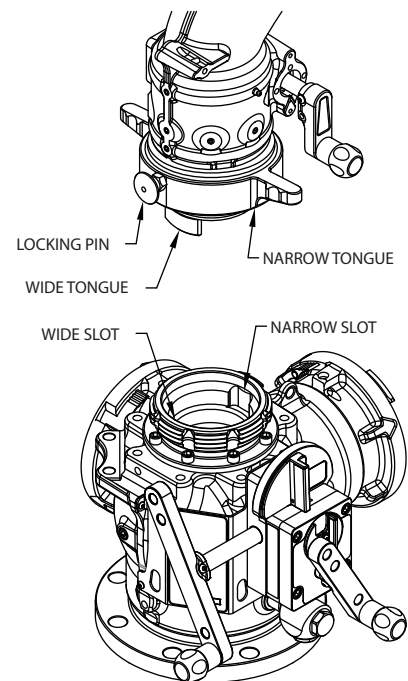

Figure 4.3.4: Quick Connect Installation

5.0 USE

5.1 VALVE OPERATION AND VALVE POSITION INDICATORS

The main shutoff valve and the monitor valve are operated using two separate crank handles marked MAIN and MONITOR. Each valve has its own valve position indicator that is color-coded and retro-reflective for visibility in low-light conditions. Figure 5.1 shows an external view on the left, and a corresponding cross-section view on the right. This cross-section view is also displayed on the nameplate of the HUM for reference during operation. These graphics show that the yellow position indicator corresponds to the side A main valve, and the orange position indicator corresponds to the side B monitor valve. When each valve is open, the position indicator is parallel to the direction of flow through the valve seats.

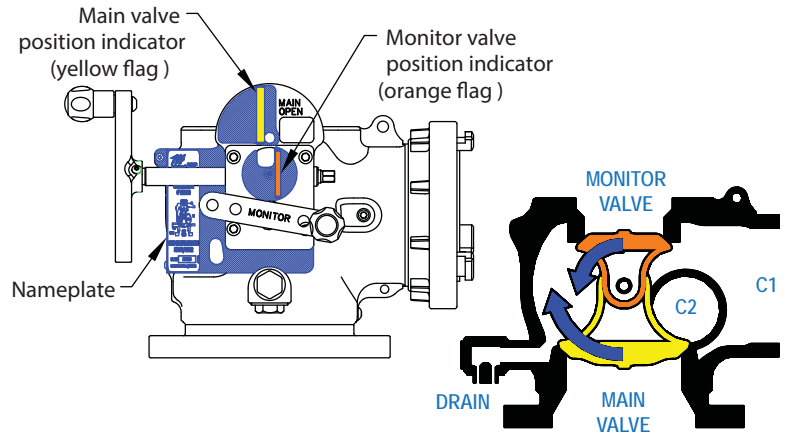

Figure 5.1: Position indicators locations and color-coded cross-section view from nameplate

5.1.1 MAIN SHUTOFF VALVE OPERATION

Refer to figure 5.1.1. To open the main valve, turn the larger crank handle marked MAIN counter-clockwise until the yellow position indicator flag is vertical and the MAIN OPEN label is fully exposed.

To close the main valve, turn the larger crank handle marked MAIN clockwise until the yellow position indicator is horizontal and the MAIN CLOSED label is fully exposed.

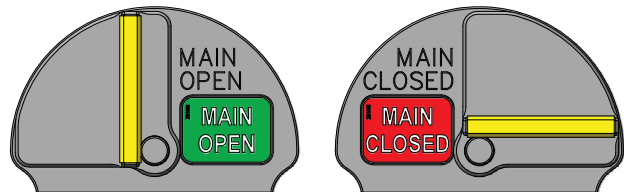

Figure 5.1.1: Main valve position indicator (yellow flag)

5.1.2 MONITOR VALVE OPERATION

Refer to figure 5.1.2. To open the monitor valve, turn the smaller crank handle marked MONITOR clockwise until the orange position indicator flag is vertical and the word OPEN is fully exposed.

To close the monitor valve, turn the smaller crank handle marked MONITOR counter-clockwise until the orange position indicator is horizontal and the word CLOSED is fully exposed.



Figure 5.1.2: Monitor valve position indicator (orange flag)

5.1.3 LOCKOUT/TAGOUT

When it is necessary to prevent operation of the HUM or monitor, the HUM crank handles may be tethered. Referring to figure 5.1.3, all suitable tether points are shown in red, and the valve crank handles are shown in blue. It is also acceptable to tether the two crank handles to each other. Polymer ties or aircraft cable (wire rope) may be used in all locations. The nameplate also allows 1/8" and smaller trade size chain to be used by inserting the lock shackle through both the chain and the crank handle.

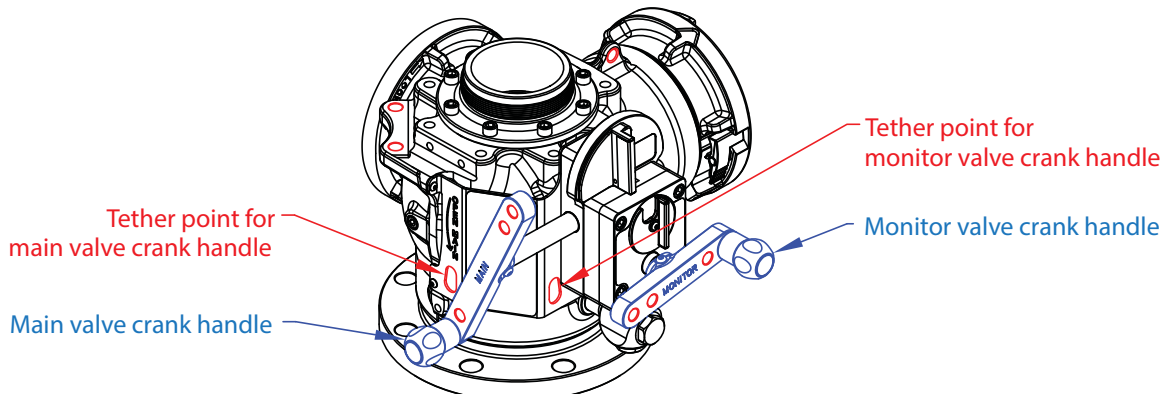

Figure 5.1.3: Tether points for Lockout/Tagout

5.2 TYPICAL USE SCENARIOS

The monitor and LDH hose ports can be used either independently or simultaneously. The scenarios below explain the valve operation for each intended use. In each graphic below, blue shading indicates water delivered from the side A inlet. See section 8.0 PRESSURE LOSS to estimate the performance of each outlet used independently or simultaneously.

NOTICE

Downstream connections can highly influence the flow rate through each outlet of the HUM. When a pump is attached downstream of any of the HUM outlets, care must be taken to avoid starving flow to any outlets that are not connected to the same pump. Independent testing is recommended to ensure the entire system meets performance requirements.

5.2.1 TOTAL SHUTOFF (side A main valve closed)

Refer to figure 5.2.1. When the Side A main valve is closed, no water will be discharged from the HUM. It is recommended to keep pressure caps on ports C1 and C2 at all times when hose connections are not being utilized, to prevent the interior of the valve from foreign debris. The automatic water drain valves described in section 5.3 will allow the valve body to drain completely even while the pressure caps are installed.

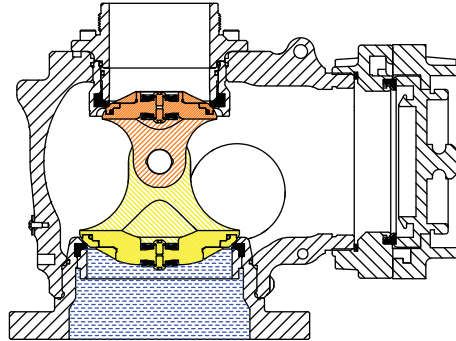

Figure 5.2.1: Total Shutoff

5.2.2 USE LDH PORTS ONLY (side A main valve open; side B monitor valve closed)

CAUTION

Prior to removing LDH caps or hoses, a downstream valve on the HUM must be opened briefly to vent any pressure stored within the HUM. The side B monitor valve may be used for this purpose, or a 1/4" NPT bleed valve may be attached to one of the two ports shown in figure 3.4.1.

Refer to figure 5.2.2. When the Side A main valve is opened, water pressure is introduced immediately to the valve body. Any hose connections needed should be properly connected through the entire system prior to opening the Side A main valve. Any unused LDH ports must have the included pressure cap or a separate valve installed prior to opening the Side A Valve. A monitor installed on Side B will not flow unless the Side B monitor valve is opened.

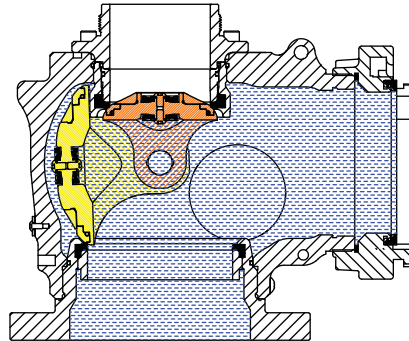

Figure 5.2.2: Use LDH ports only

5.2.3 USE MONITOR ONLY (both valves open; caps installed on LDH ports)

Refer to figure 5.2.3. When both the Side A and Side B valves are opened, water pressure is supplied to the monitor and the LDH ports. In order to use the monitor only, the included pressure caps or separate valves must be installed on the LDH ports C1 and C2 prior to opening the Side A valve.

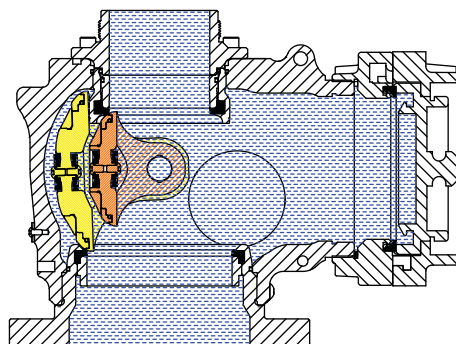

Figure 5.2.3: Use monitor only

NOTICE

In this scenario, pressure will be stored in the HUM if the side B monitor valve is closed before the side A main valve is closed. A downstream valve on the HUM must be opened briefly to vent any pressure and allow the automatic drain valve function to begin. The side B monitor valve may be used for this purpose, or a 1/4" NPT bleed valve may be attached to one of the two ports shown in figure 3.4.1. When the external drain valve begins to flow continuously, the downstream bleed valve may be closed completely. Drainage will continue until the Hydrant Under Monitor is empty.

5.2.4 USE MONITOR AND LDH PORTS SIMULTANEOUSLY (both valves open; LDH cap(s) removed)

CAUTION Prior to removing LDH caps or hoses, a downstream valve on the HUM must be opened briefly to vent any pressure stored within the HUM. The side B monitor valve may be used for this purpose, or a 1/4" NPT bleed valve may be attached to one of the two ports shown in figure 3.4.1.

Refer to figure 5.2.4. When both the Side A and Side B valves are opened, water pressure is supplied to the monitor and the LDH ports. Any hose connections that will be needed must be connected prior to opening the Side A main valve. Any unused LDH ports must have the included pressure cap or a separate valve installed prior to opening the Side A Valve. If the LDH port(s) are used to feed a pump, the monitor nozzle pressure must be monitored to ensure the desired nozzle flow rate is maintained.

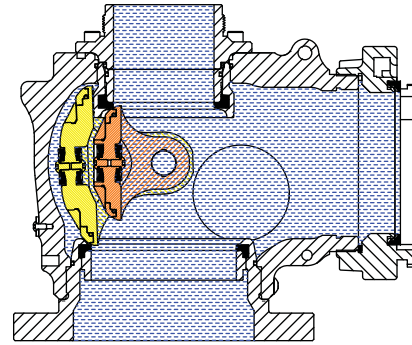

Figure 5.2.4: Use monitor and LDH ports simultaneously

5.2.5 USE WITH ZC-SERIES BOOSTER OR ZD-SERIES OSCILLATOR

Refer to figure 5.2.5. When a Booster or Oscillator is installed on the HUM, the monitor and LDH ports may be used exactly as described previously in sections 5.2.1 through 5.2.4. In these cases, the swing-check valve (clapper) within the Booster or Oscillator will remain closed to keep port C3 sealed.

To boost the discharge pressure or introduce foam solution to the monitor, see section 5.2.6.

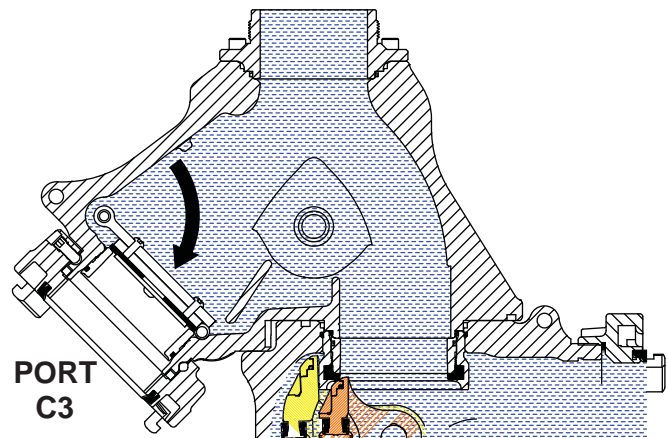

Figure 5.2.5: Use with Booster or Oscillator

5.2.6 PRESSURE BOOST OR FOAM SOLUTION USING ZC-SERIES BOOSTER OR ZD-SERIES OSCILLATOR

Refer to figure 5.2.6. Blue shading indicates water delivered from the side A inlet and purple shading indicates water that has been supplemented by a pump and/or foam eductor.

To boost the discharge pressure or introduce foam solution to the monitor, follow the steps below. See LIZ-060 for further details on use of the ZC-Series Booster.

NOTICE

Keep the Side B monitor valve closed at all times to prevent backflow into the standpipe.

1. With the Side A main valve closed, connect a hose from port C1 of the HUM to the inlet of a pump or foam eductor.
2. Connect hose from the outlet of the pump or eductor to port C3 of the Booster or Oscillator.
3. Open this Side A main valve and any other valves in-line with the pump or eductor. The swing-check valve in the Booster or Oscillator will swing open and the monitor will begin to flow. The pump may now be throttled to achieve the desired nozzle performance.
4. When operation is completed, close Side A main valve and vent the pressure. The HUM drain valves will fully drain the Booster and HUM without allowing any to backflow into the standpipe.

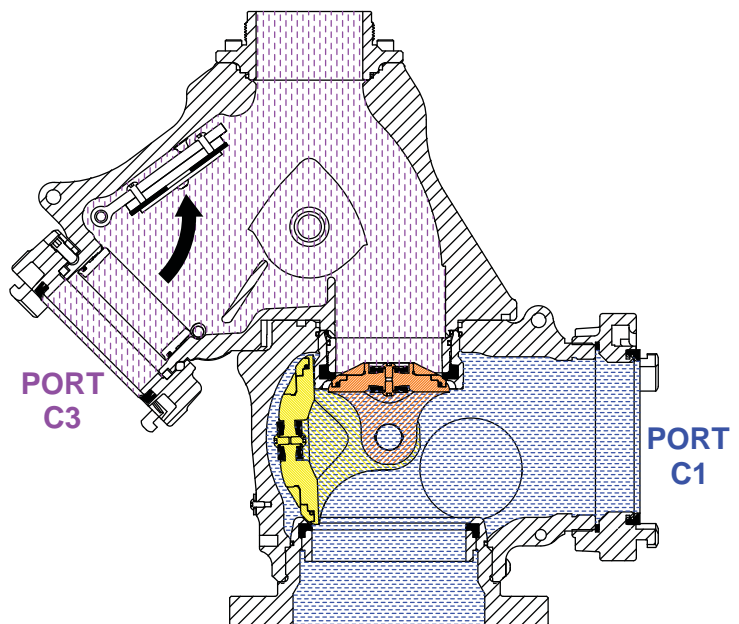

Figure 5.2.6: Pressure Boost or Foam Solution

5.3 DRAINING RESIDUAL WATER

NOTICE

All monitors, valves and standpipes exposed to freezing conditions must be drained immediately following use to prevent damage. To drain a standpipe, a drainage port must be opened underground below the frost depth to keep water out of the standpipe until the next use. Both the main and monitor valves in the HUM must be vented to prevent vacuum from suspending the water in the standpipe. Venting can be performed by either opening both valves manually, or through proper use of automatic water drain valves.

Some usage scenarios will result in pressure being stored within the Hydrant Under Monitor, which will prevent the drain valves from opening automatically. When the side A main shutoff valve is closed following use, the user must verify that a stream of water has exited the external drain valve continuously for several seconds. If no water has exited the external drain valve, a downstream valve on the HUM must be opened briefly to vent any pressure and allow the automatic drain function to begin. The side B monitor valve may be used for this purpose, or a 1/4" NPT bleed valve may be attached to one of the two ports shown in figure 3.4.1. When the external drain valve begins to flow continuously, the downstream bleed valve may be closed completely. Drainage will continue until the Hydrant Under Monitor is empty.

Automatic water drain valves allow the monitor and HUM body to drain fully after the half balls are closed, which minimizes susceptibility to damage from corrosion and freezing water. The drain valve seal membranes are designed to close automatically when pressure exceeds 5 psi. When pressure drops below 5 psi, the seal membranes will open to allow drainage. Proper function must be verified prior to fireground use. When the automatic drain valves are omitted or disabled, the half balls must be manually opened for venting and drainage. The two standard and one optional drain valve location are described in the following sections and illustrated in figure 5.3.

5.3.1 EXTERNAL DRAIN VALVE (STANDARD)

All HUM models are equipped with an external automatic drain valve attached to a port located directly above the valve seat, just below the gearbox. The external drain valve ensures the HUM valve body is completely drained following use. This drain valve uses a single seal membrane, since pressure will always be applied from the inside of the valve.

5.3.2 SIDE B DRAIN VALVE IN MONITOR HALF BALL (STANDARD)

All HUM models are equipped with an automatic drain valve integrated within the monitor half ball (side B). The side B drain valve allows the monitor and HUM to drain fully after the monitor half ball is closed. This drain valve includes one seal membrane on each side of the half ball (two total), in order to seal pressure either from the side A inlet, or from a ZC-series Booster or ZD-series Oscillator installed on Side B.

5.3.3 SIDE A DRAIN VALVE IN MAIN HALF BALL (OPTIONAL)

An automatic drain valve located within the main half ball (side A) allows the standpipe to draw atmospheric air to facilitate draining, even while the main half ball is closed. It is beneficial in applications where the standpipe will typically be drained following use, especially where freezing conditions are a concern. This drain valve includes one sealing membrane on each side of the half ball (two total), in order to seal pressure either from the side A inlet, or from supply hoses attached to any of the LDH ports on the HUM, Booster, or Oscillator. This prevents backflow into the standpipe when the pressure within the HUM exceeds the pressure within the standpipe.

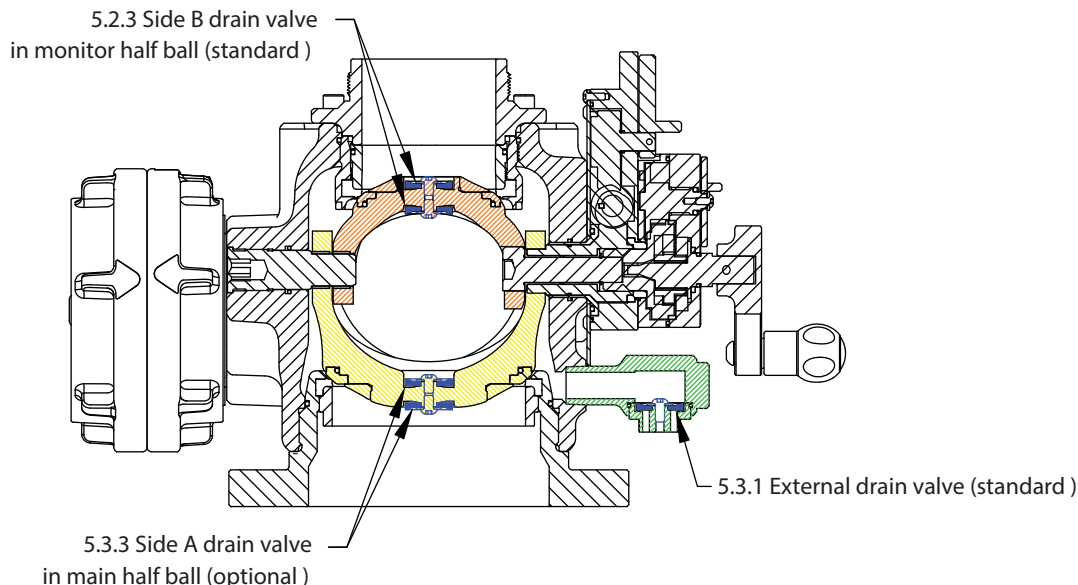
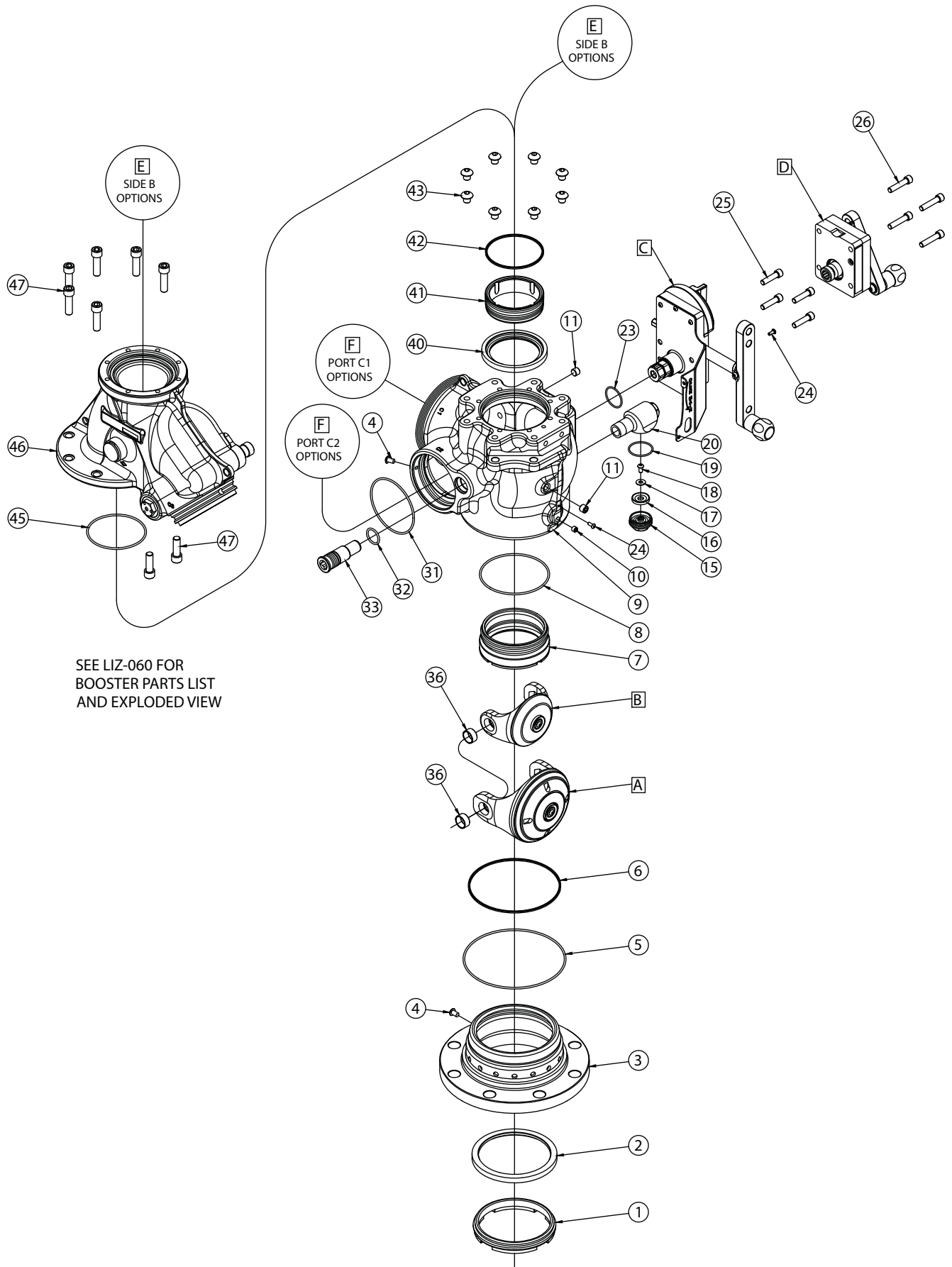

Figure 5.3: Automatic Water Drain Valves

6.0 EXPLODED VIEWS AND PARTS LISTS

6.1 OVERALL ASSEMBLY

Subassemblies and optional components marked [A] through [F] are shown exploded on following pages



SEE LIZ-060 FOR
BOOSTER PARTS LIST
AND EXPLODED VIEW

6.1 OVERALL ASSEMBLY

INDEX	DESCRIPTION	QTY	PART #
1	SEAT RETAINER 6" ALUMINUM	1	ZB1025A
2	6" VALVE SEAT	1	A1082
3	FLANGE 6" ANSI 150 ALUMINUM	1	ZB1020A-ARED
4	5/16-18 X 1/2 SOCKET HEAD SCREW	2	VT31-18SH500
5	O-RING-263	1	VO-263
6	QUAD-RING-4260	1	VOQ-4260
7	OUTER SEAT RETAINER	1	ZB1030A
8	O-RING-249	1	VO-249
9	VALVE BODY IVUM 6"	1	ZB1000-ARED
10	3/8-16 X 5/16 SOCKET SET SCREW	1	VT37-16SS312
11	1/4"NPT PLUG	2	VFSP2M-SS
15	DRAIN HOUSING	1	X375
16	DRAIN VALVE MEMBRANE	1	X382
17	FLAT WASHER 1/4" STAINLESS 18-8	1	VW687X281-50
18	1/4-20 X 1/2 BUTTON HEAD SCREW	1	VT25-20BH500
19	O-RING-130	1	VO-130
20	DRAIN HOUSING 3/4"NPT MALE	1	ZB1010
23	O-RING-128	1	VO-128
24	10-24 X 3/8 BUTTON HEAD SCREW	2	VT10-24BH375
25	3/8-16 X 1-1/2 SOCKET HEAD SCREW	4	VT37-16SH1.5
26	3/8-16 X 1-3/4 SOCKET HEAD SCREW	4	VT37-16SH1.7
31	VO-RING-244	1	VO-244
32	VO-RING-215	1	VO-215
33	FIXED TRUNNION ALUMINUM	1	ZB1035A
36	BUSHING	2	A2094
40	VALVE SEAT BIV	1	A1520
41	INNER SEAT RETAINER ALUMINUM	1	A2071A
42	QUAD-RING-242	1	VOQ-4242
43	1/2-13 X 1/2 BUTTON HEAD SCREW	8	VT50-13BH500
45	O-RING-243	1	VO-243
46	BOOSTER ASSEMBLY	1	SEE LIZ-060
	INDUSTRIAL OSCILLATOR ASSEMBLY	1	SEE LIZ-065
47	1/2-13 X 1-1/2 SOCKET HEAD SCREW	8	VT50-13SH1.5
A	MAIN HALF BALL 8" DIAMETER	--	SEE SECTION 6.2
B	MONITOR HALF BALL 5.5" DIAMETER	--	SEE SECTION 6.2
C	MAIN VALVE GEARBOX	--	SEE SECTION 6.3
D	MONITOR VALVE GEARBOX	--	SEE SECTION 6.4
E	SIDE B OPTIONS	--	SEE SECTION 6.5
F	PORTS C1 AND C2 OPTIONS	--	SEE SECTION 6.6

6.2 MAIN HALF BALL [A] AND MONITOR HALF BALL [B]

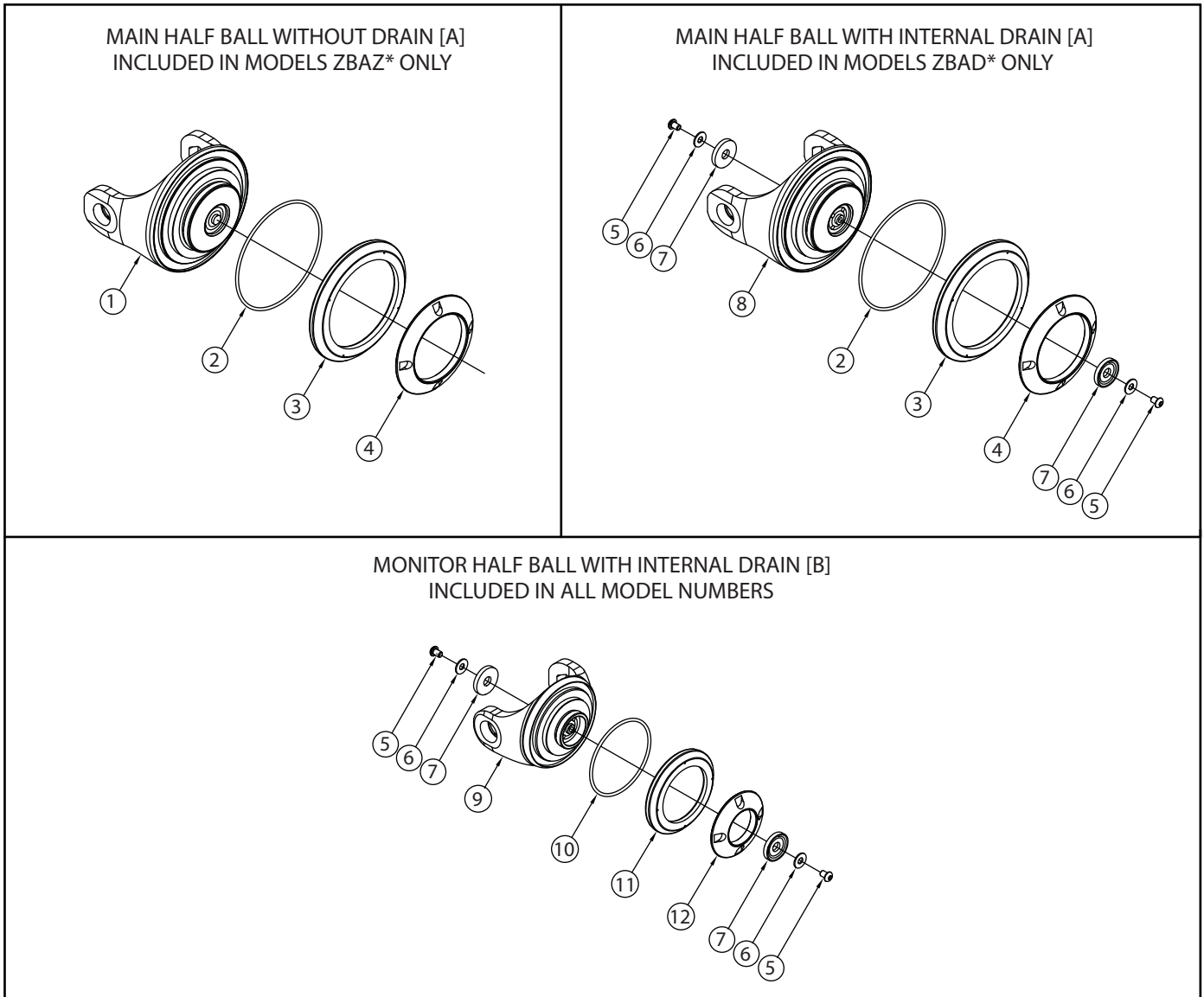

Quantities below are per half ball

INDEX	DESCRIPTION	QTY	PART #
1	HALF BALL 8" ALUMINUM	1	ZB1070
2	O-RING-249	1	VO-249
3	SEAT INSERT 8" SPHERICAL	1	ZB1071
4	SEAT RETAINER 8" HALF BALL	1	ZB1072
5	1/4-28 X 3/8 BUTTON HEAD SCREW	2	VT25-28BH375
6	FLAT WASHER 1/4"	2	VW687X281-50
7	DRAIN VALVE MEMBRANE	2	X382
8	HALF BALL 8" ALUMINUM WITH DRAIN	1	ZB1073
9	HALF BALL 5.5" ALUMINUM WITH DRAIN	1	A2093
10	O-RING-237	1	VO-237
11	SEAT INSERT 5.5" SPHERICAL	1	A2091
12	SEAT RETAINER 5.5" HALF BALL	1	A2092

6.3 MAIN VALVE GEARBOX [C]

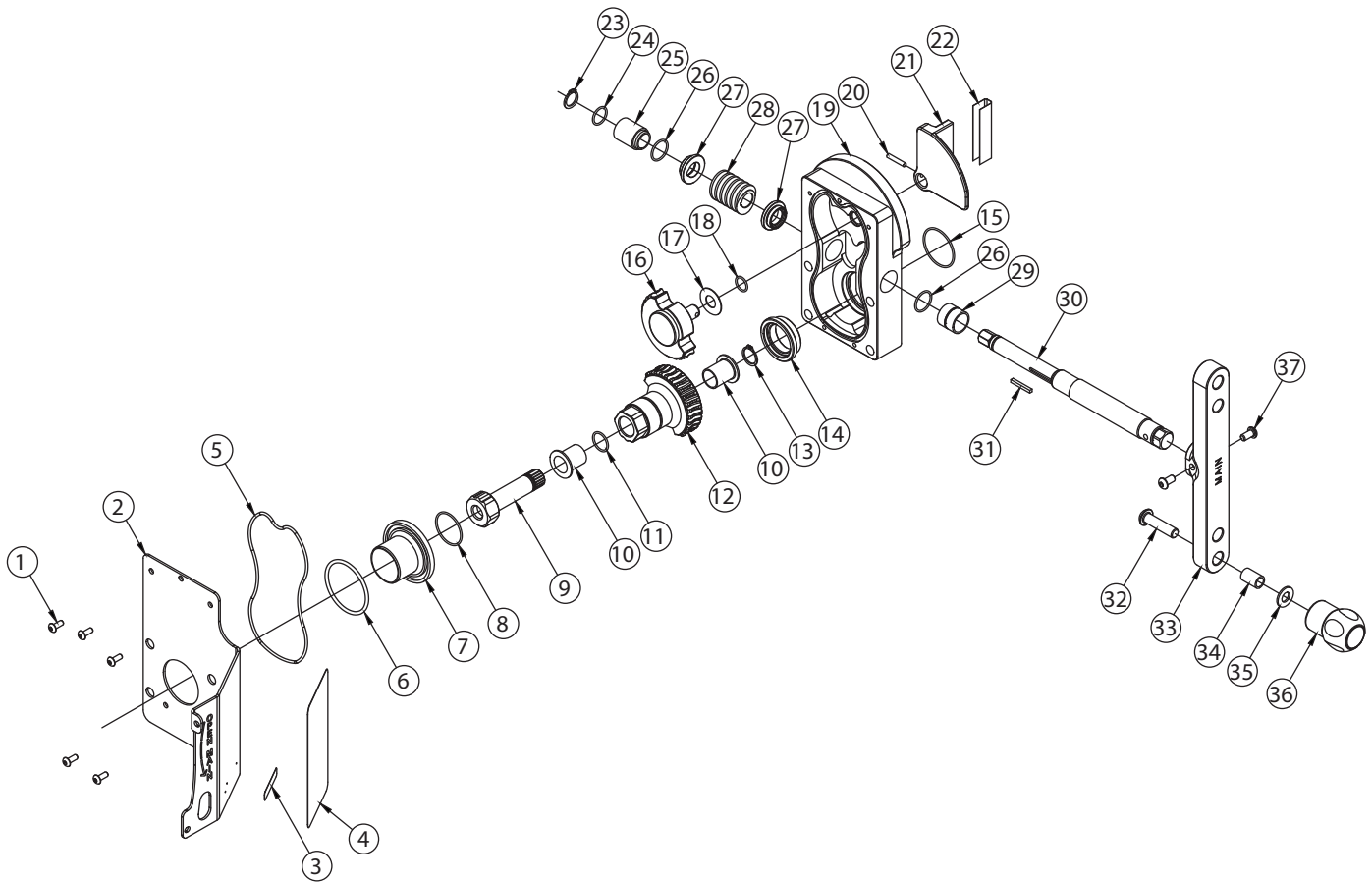

INDEX	DESCRIPTION	QTY	PART #
1	10-24 X 3/8 BUTTON HEAD SCREW	5	VT10-24BH375
2	GEARBOX COVER	1	ZB1051
3	MODEL NUMBER LABEL	1	A1303
4	NAME LABEL HUM WITHOUT APPROVAL MARK	1	ZB1059
	NAME LABEL HUM FM APPROVED	1	ZB1059-FM
5	O-RING-160	1	VO-160
6	O-RING-226	1	VO-226
7	TRUNNION BUSHING	1	ZB1056
8	O-RING-026	1	VO-026
9	INNER TRUNNION	1	ZB1058
10	INNER TRUNNION BUSHING	2	ZB1057
11	O-RING-017	1	VO-017
12	OUTER TRUNNION	1	ZB1052
13	RETAINING RING 11/16" EXTERNAL	1	VR4330
14	INNER TRUNNION BUSHING	1	ZB1053
15	O-RING-029	1	VO-029
16	INNER TRUNNION	1	ZB1054
17	GEAR THRUST WASHER	1	A1502
18	O-RING-014	1	VO-014
19	GEARBOX	1	ZB1050

INDEX	DESCRIPTION	QTY	PART #
20	5/32 X 7/8 HDP SPIROL PIN	1	V1900
21	MAIN VALVE POSITION INDICATOR	1	ZB1055
22	POSITION INDICATOR LABEL	1	A1524
23	RETAINING RING	1	VR4275
24	O-RING-016	1	VO-016
25	LARGE BUSHING	1	A1528
26	O-RING-018	2	VO-018
27	WORM THRUST WASHER	2	A1529
28	12 DP WORM	1	X220
29	SMALL BUSHING	1	A1527
30	EXTENDED SHAFT	1	ZB1060
31	KEY	1	X225
32	3/8-16 X 1-1/2 BUTTON HEAD SCREW	1	VT37-16BH1.5
33	T-HANDLE CRANK	1	ZB1061
34	CRANK BUSHING	1	A1547
35	WASHER	1	VW812X406-65
36	KNOB	1	A1512
37	1/4-20 X 1/2 BUTTON HEAD SCREW	2	VT25-20BH500

6.4 MONITOR VALVE GEARBOX [D]

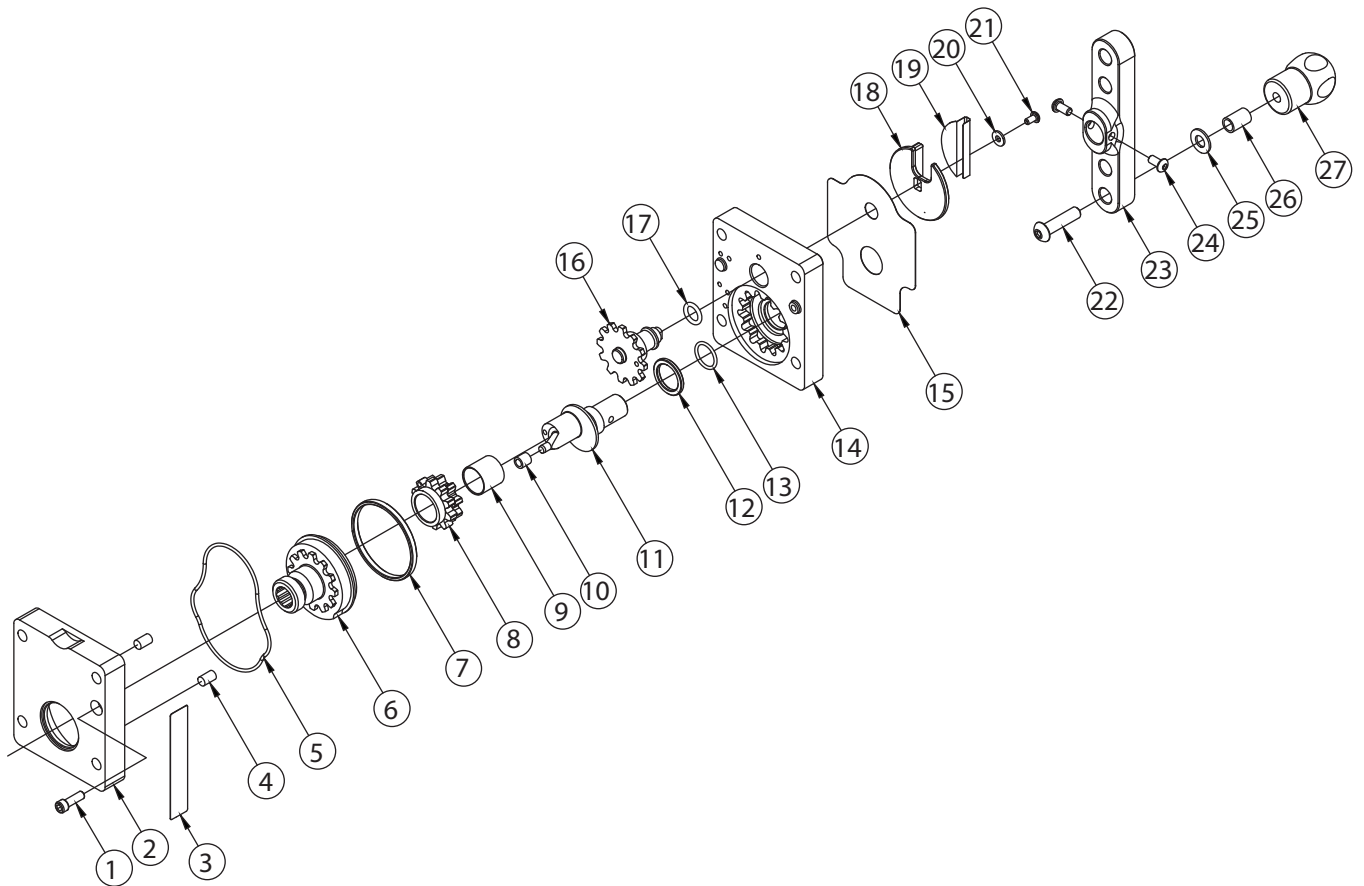

INDEX	DESCRIPTION	QTY	PART #
1	1/4-20 X 3/4 SOCKET HEAD SCREW	1	VT25-20SH750
2	SUBPLATE	1	A1551
3	WARNING LABEL	1	ZB1069
4	DOWEL PIN	2	VP312X.50
5	O-RING-154	1	VO-154
6	INNER TRUNNION GEAR	1	ZB1063
7	BUSHING	1	A1549
8	DOUBLE GEAR	1	A1554
9	GEAR BUSHING	1	A1548
10	NYLON BUSHING	1	AY307
11	DRIVE SHAFT	1	A1555
12	ACETAL WASHER	1	A1556
13	O-RING-116	1	VO-116
14	GEAR BOX	1	A1550-1

INDEX	DESCRIPTION	QTY	PART #
15	MONITOR GEARBOX LABEL	1	ZB1067
16	INDICATOR GEAR	1	A1557
17	O-RING-206	1	VO-206
18	MONITOR VALVE POSITION INDICATOR	1	ZB1064
19	MONITOR INDICATOR LABEL	1	ZB1068
20	WASHER	1	VW500X203-60
21	10-32 X 3/8 BUTTON HEAD SCREW	1	VT10-32BH375
22	3/8-16 X 1-1/2 BUTTON HEAD SCREW	1	VT37-16BH1.5
23	CRANK	1	A1559
24	1/4-20 X 1/2 BUTTON HEAD SCREW	2	VT25-20BH500
25	WASHER	1	VW812X406-65
26	CRANK BUSHING	1	A1547
27	KNOB	1	A1512

6.5 SIDE B OPTIONS [E]

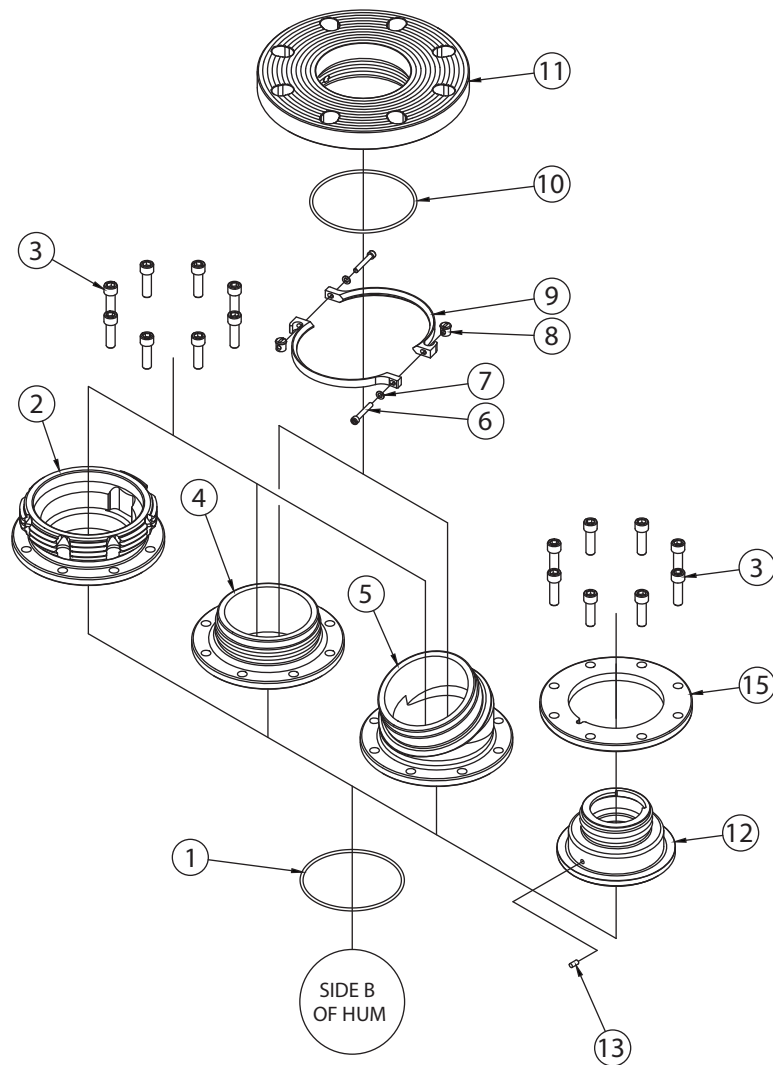

INDEX	DESCRIPTION	QTY	PART #
1	O-RING-243	1	VO-243
2	QUICK CONNECT - VUM X 4.5"NHM	1	Y4484
3	3/8-16 X 1 1/4 SOCKET HEAD SCREW	8	VT37-16SH1.2
4	OUTLET VUM CODE-RPM	1	A1026
5	OUTLET VUM 22.5 DEGREE CODE-RPM	1	A1040
6	10-32 X 1-1/4 SOCKET HEAD SCREW	2	VT10-32SH1.2
7	WASHER	2	VW360X200-04
8	CYLINDER NUT	2	Y4437
9	4" MONITOR BASE CLAMP	2	Y4435
10	O-RING-244	1	VO-244
11	FLANGE CODE-RPF X 4"ANSI 150	1	A1039
12	QUICK CONNECT - VUM X 2.5"NHM	1	Y2432A
13	3/16 X 3/8 HDP SPIROL PIN	1	VP188X.38HDP
15	FLANGE VUM FOR SMALL MONITORS	1	Y2433

6.6 PORTS C1 AND C2 OPTIONS [F]

6.6.1 NH MALE THREADED SPOUT AND GATED WYE OPTION

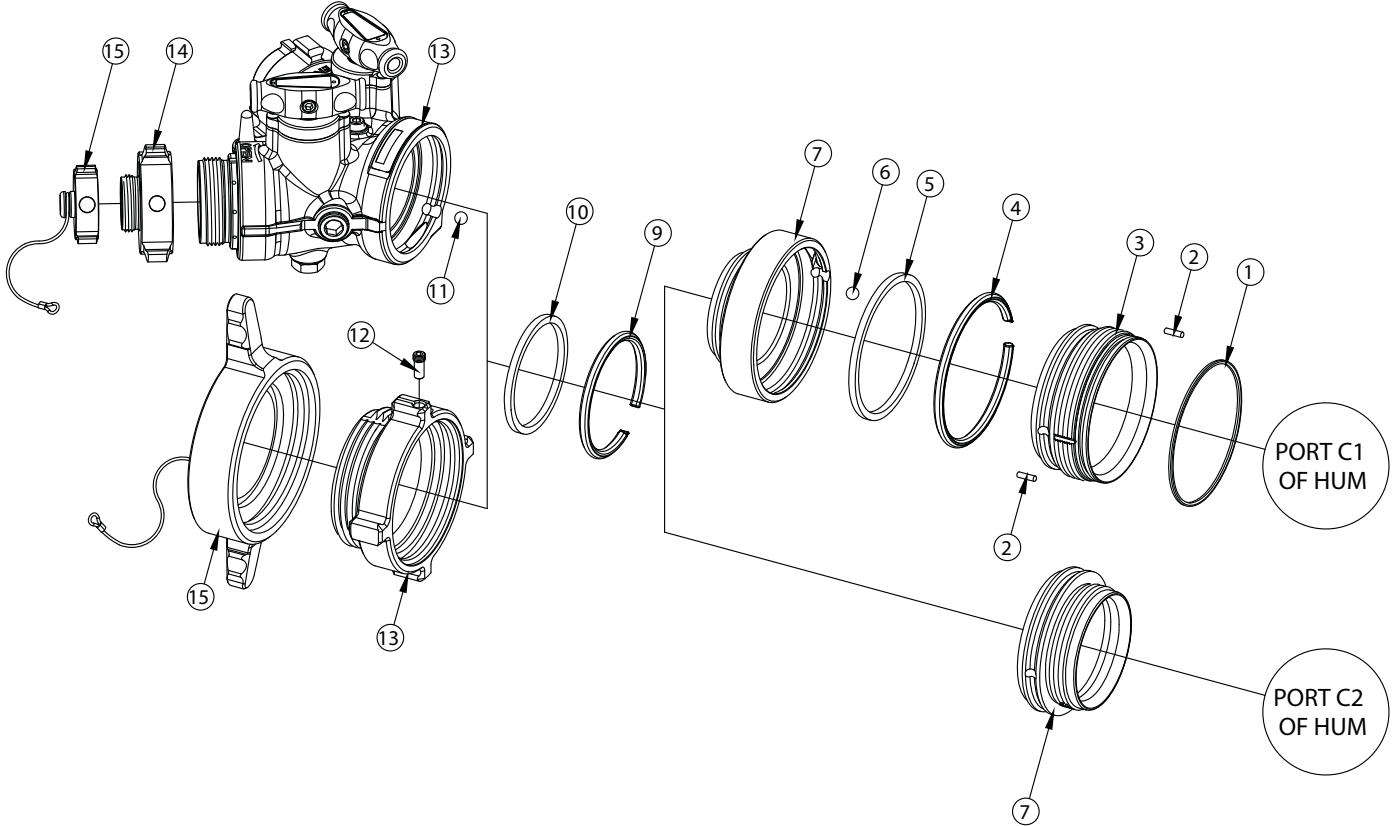

- Different parts are used to achieve the same connection type, depending on whether it is installed on port C1 or port C2.
- Items designated "--" in the table below are not used for the particular connection type.
- Items designated NOT AVAILABLE cannot be installed on that particular port.

#	DESCRIPTION	PARTS USED PER CONNECTION TYPE							
		2.5" SPOUT	2.5" GATED WYE	3.0" SPOUT	3.5" SPOUT	4.0" SPOUT	4.5" SPOUT	5.0" SPOUT	6.0" SPOUT
1	QUAD-RING	VOQ-4250							
2	10-24 X 3/4 SOCKET SET SCREW	VT10-24SS750							
3	ADAPTER 5" BSPM x PSM 5.25	ZB1011							
4	PLASTIC STRIP 5.25"	A1291	A1291	A1291	A1291	--	--	--	--
5	CUP SEAL LOADED 5.25"O.D.	A1596	A1596	A1596	A1596	--	--	--	--
6	7/16" SS BALL	VB.437	VB.437	VB.437	VB.437	--	--	--	--
7	MATE FOR PORT C1	A4730	A4730	A4730	A4730	--	--	--	--
8	MATE FOR PORT C2	ZB1012	ZB1012	ZB1012	ZB1012	ZB1013	ZB1013	ZB1013	NOT AVAILABLE
9	PLASTIC STRIP	A1292	A1292	A1292	A1292	A1291	A1291	A1291	A1291
10	CUP SEAL LOADED	A1597	A1597	A1597	A1597	A1596	A1596	A1596	A1596
11	7/16" SS BALL	VB.437	VB.437	--	--	--	--	--	--
12	LOCK-OUT SCREW	--	--	A1294	A1294	A1294	A1294	A1294	A1294
13	SPOUT/WYE	A4605	AY906	A4610	A4615	A4620N	A4625N	A4630N	A4635N
14	REDUCER FEMALE X MALE	P411NJNF	P411NJNF	--	--	--	--	--	--
15	BLIND CAP W/LANYARD	P412NF	P412NF	A01NL	A01NN	A01NP	A01NR	A01NT	A01NX

6.6.2 STORZ COUPLING OPTIONS

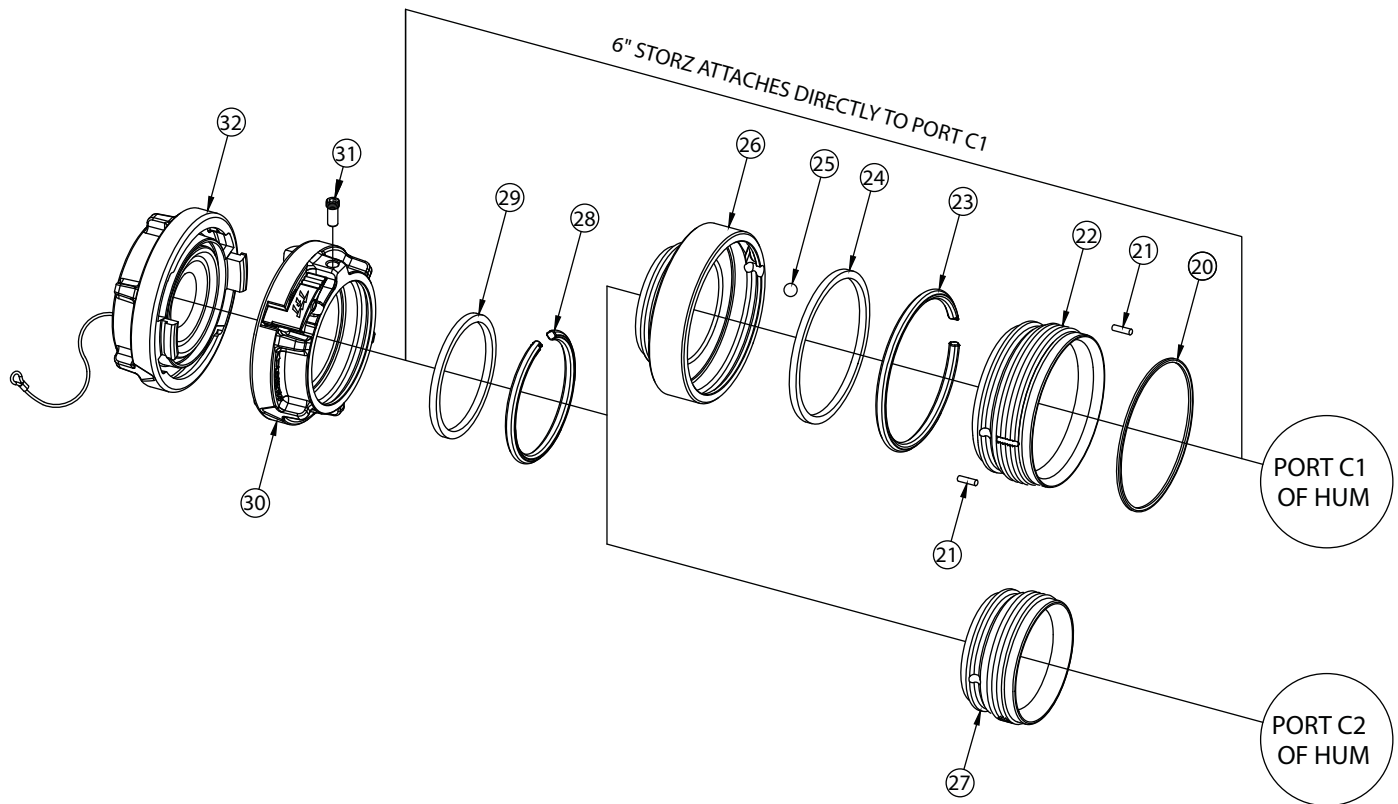

- Different parts are used to achieve the same connection type, depending on whether it is installed on port C1 or port C2.
- Items designated “--” in the table below are not used for the particular connection type.
- Items designated NOT AVAILABLE cannot be installed on that particular port.

INDEX	DESCRIPTION	PARTS USED PER CONNECTION TYPE		
		4" STORZ	5" STORZ	6" STORZ
20	QUAD-RING	VOQ-4250	--	--
21	10-24 X 3/4 SOCKET SET SCREW	VT10-24SS750	--	--
22	ADAPTER 5" BSPM x PSM 5.25	ZB1011	--	--
23	PLASTIC STRIP 5.25"	A1291	--	--
24	CUP SEAL LOADED 5.25" O.D.	A1596	--	--
25	7/16" SS BALL	VB.437	--	--
26	MATE FOR PORT C1	A4730	--	--
27	MATE FOR PORT C2	ZB1012	ZB1013	NOT AVAILABLE
28	PLASTIC STRIP	A1292	A1291	--
29	CUP SEAL LOADED	A1597	A1596	--
30	STORZ ASSEMBLY	A4124	A4125	X696SX-LOCK
31	LOCK-OUT SCREW	A1294	A1294	--
32	BLIND CAP STORZ W/LANYARD	A4144.1	A4145.1	A4186.1

6.6.3 BLIND PLUG OPTION

INDEX	DESCRIPTION	PART
--	PLUG FOR PORT C1	NOT AVAILABLE
42	PLUG FOR PORT C2	ZB1014

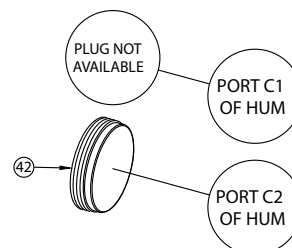

7.0 FM APPROVAL (FACTORY MUTUAL)



FM Approved HUM models are identified with the symbol  on their labels and are listed for use with FM Approved monitor assemblies under FM Approval Class 1421 - Monitor Assembly. These models have also been verified to meet the applicable performance requirements of FM Approvals Class 1112 - Approval Standard for Indicating Valves (Butterfly or Ball Type). RC valves are not FM Approved.

8.0 MAINTENANCE AND REPAIRS

The Hydrant Under Monitor requires no routine maintenance. The gearboxes are sealed and require no periodic greasing. Valve seats may be greased as needed with a silicone based grease such as Dow Corning 112. Any scrapes that expose bare aluminum should be cleaned and touched up with enamel paint such as Rust-Oleum. Replace any missing or damaged parts before returning the valve to service.

The Hydrant Under Monitor should be inspected annually and after each use. In particular, check that:

- There are no leaks with the valves off or while flowing.
- Crank handles move freely between the open and closed positions.
- Valve position indicators correctly reflect valve positions between open and closed positions.

8.1 MAIN VALVE CRANKSHAFT OVERRIDE AND REPLACEMENT

The main valve crankshaft includes an intentional shear joint to protect the half ball and gear train from overload, costly repairs and loss of service. The magnitude of torque required to shear the crankshaft is much greater than the torque typically needed to operate the valve at maximum operating pressure. If the crankshaft breaks during use, this is an indication that either there is something obstructing the half ball internally or the crank shaft has been abused (e.g. used as a step for climbing). The crankshaft can be safely overridden, removed and replaced without removing the gearboxes from the HUM as described in the following sections.

NOTICE

For maximum safety it is recommended to shutoff the water supply and relieve pressure within the HUM prior to any maintenance procedures. However, in compliance with regulatory standards, a broken crankshaft can be safely removed and replaced whether or not the HUM contains internal pressure up to the rated working pressure of 300 psi (21 bar).

8.1.1 OVERRIDE

The crankshaft has a male hex end protruding from the gearbox that can be turned using a 1/2" wrench or hex socket. This allows the valve to be open or closed until the crankshaft is replaced. This is not intended as a long-term method of operation. The crankshaft should be replaced as soon as possible as described in section 7.1.3. To prevent loss of the 1/8" square key on the crankshaft, do not allow the crankshaft to slide out the of gearbox until a replacement crankshaft is acquired.

8.1.2 DIAGNOSIS

To diagnose the problem that caused the crankshaft to fail, complete the following steps:

1. Close the upstream water supply and relieve pressure leading up to the main valve.
2. Open the monitor valve to relieve all internal pressure from the HUM.
3. Remove cap(s) from port C1 to observe whether there is any internal debris obstructing movement of the half ball.
4. Locate 1/2" hex where crankshaft protrudes from gearbox.
5. Gently turn crank shaft away from travel stop using a 1/2" hex wrench. To prevent further damage, do not strike the wrench with a hammering action and do not exceed 50 ft-lb (68 Nm) of torque.
6. If crankshaft will not rotate, then half ball is likely obstructed. The HUM must be disconnected at the flanged joint for inspection and possible repair. Ensure upstream water supply has been shut off. Disconnect any hoses or devices on C1 & C2 ports. Loosen the flange bolts in the pattern described in section 4.1. Clear any obstructions and evaluate whether repair is needed before returning to service.
7. If crankshaft is able to rotate, cycle the valve several times from open to closed to determine whether the crankshaft binds at any place between the travel stops. If crankshaft binds after some rotation, consult Task Force Tips Service Department for further troubleshooting.
8. If crankshaft rotates freely after clearing any obstructions, then a replacement crank shaft may be ordered from Task Force Tips and replaced as described in section 7.1.3.

8.1.3 REPLACEMENT

1. Remove external retaining ring (index 23) adjacent to 1/2" hex on crankshaft.
2. Using a punch or Phillips head screwdriver at least 6" in length, gently push on dimple in 1/2" hex end of crankshaft (index 30). Continue to push crankshaft through until it protrudes from opposite side of gearbox.
3. Grab broken end of crankshaft and pull it out of the gearbox. As crankshaft is withdrawn, grasp 1/8" square key (index 31) on shaft so it does not get lost.
4. If 1/8" square x 1" long key is not visible in shaft, it has likely fallen into gearbox bore and must be removed before installing new crankshaft. If square key is visible in gearbox bore, slide it out of bore. Needle-nose pliers may be helpful depending on position of key in bore.
5. Verify polymer bushings (index 25 and 29) are still seated in bores on each side of gearbox. If not, locate and replace bushings.
6. Look through gearbox bore and note approximate orientation of square keyway in worm (index 28). Verify round notch in thrust washer (index 27) is aligned with square keyway in worm.
7. Prepare new crankshaft by applying small dab of grease to keyway and seating 1/8" square x 1" long key into keyway. Grease will keep key in place during assembly.
8. Slide shaft into gearbox with key orientation the same as keyway in worm. Rotate shaft slightly in alternating directions until key finds keyway, then push shaft in until it stops. Retaining ring groove and 1/2" hex should be protruding through opposite side of gearbox. If hex is not visible, it may be necessary to slide polymer bushing back into gearbox bore.
9. Install retaining ring (index 23) onto shaft. Do not over-expand the retaining ring.

8.2 MONITOR VALVE GEARBOX DIAGNOSIS AND REPLACEMENT

The monitor valve gearbox includes an intentional shear joint on the output shaft that is designed to fail before any of the other components in the HUM are significantly damaged. This feature is intended to minimize costly repairs and loss of service. The magnitude of torque required to shear the output is much greater than the torque typically needed to operate the valve at maximum operating pressure. If the output shaft breaks during use, this is an indication that either there is something obstructing the half ball internally or the gearbox has been abused. The monitor valve gearbox must be repaired and/or replaced to resume proper operation of the HUM. Spare gearboxes may be purchased ahead of time to allow immediate repairs in the field.

NOTICE

For maximum safety it is recommended to shutoff the water supply and relieve pressure within the HUM prior to any maintenance procedures. However, in compliance with regulatory standards, the monitor valve gearbox can be safely removed and replaced whether or not the HUM contains internal pressure up to the rated working pressure of 300 psi (21 bar).

8.2.1 DISASSEMBLY AND DIAGNOSIS

Refer to the index numbers in section 6.1 and follow the steps below:

1. Close the upstream water supply and relieve pressure leading up to the monitor valve.
2. After relieving all internal pressure, remove cap(s) from port C1 to observe whether there is any internal debris obstructing movement of the half ball.
3. Remove the four socket head cap screws (index 26) from the monitor valve gearbox (index [D]), then pull the gearbox away from the HUM. Save these screws for reassembly.
4. Remove o-ring (index 15 of section 6.3) from main gearbox (index [C]). Save the o-ring for reassembly.

DO NOT REMOVE the four socket heat screws (index 25) from the main valve gearbox (index [C]).

5. If the serrated spline socket of the output shaft is still attached to the gearbox, then the output shaft has not sheared. Consult Task Force Tips Service Department for further troubleshooting.
6. If the output shaft has sheared, an edge of bare aluminum will be visible on the output shaft where the spline socket was formerly located. A broken remnant of the output shaft will be visible in the trunnion bore of the main valve gearbox, around the inner trunnion. This broken remnant will appear as a ring with a tapered outer edge and an edge of bare aluminum exposed where the shear occurred. Remove the broken remnant of the output shaft using pliers. The entire monitor gearbox must be sent to Task Force Tips to determine whether it is repairable or requires a complete replacement.

8.2.2 REPLACEMENT

To replace the gearbox, refer to the index numbers in section 6.1 and follow the steps below:

1. Install o-ring (index 15 of section 6.3) around the bushing that protrudes from the main valve gearbox (index [C]).
2. Align the notch on the outer diameter of the monitor valve gearbox output shaft with the groove on the exposed face of the inner trunnion. Slide the output shaft over the inner trunnion, wiggling as needed to get the serrated spline teeth to engage. When completed, the monitor valve gearbox should be flush against the main valve gearbox.
3. Rotate the monitor valve crank handle until the two gearboxes are aligned. If the valve is not pressurized, then the entire monitor valve gearbox may be twisted to align the two gearboxes.
4. Apply blue Loctite to threads of four socket head cap screws (index 26), then insert them into the holes in the monitor valve gearbox (index [D]) and tighten until snug.
5. Gently cycle the monitor valve to the fully open position, then the fully closed position. If this test is successful, the HUM is ready for use. If abnormal resistance is encountered during operation, stop immediately and consult Task Force Tips Service Department for further troubleshooting.

8.3 VALVE SEAT REPLACEMENT

Each valve seat may be replaced in the field if it becomes a source of leakage due to harsh environmental conditions or excessive age. Procedures for the main and monitor valve seats are described below. For the valve seats in the 2.5" gated wye option, see LIA-355.



Safety goggles are recommended to avoid eye injury while servicing the valve seats. A high velocity jet of water may exit the valve seat at any time while pressure is contained.

8.3.1 REMOVAL OF MONITOR, BOOSTER, AND OSCILLATOR

Monitor removal is necessary for replacement of the Side B monitor valve seat, and will also make the HUM easier to maneuver for replacement of the Side A main valve seat. Referring to index numbers shown in sections 6.1 and 6.2, follow the steps below:

1. Close upstream water supply and relieve pressure leading up to valve.
2. Remove the monitor and Side B Outlet Adapter from HUM. This procedure varies depending on the connection type.
 - a. For models with a ZC-series Booster or ZD-series Oscillator installed, remove (8) Socket Head Cap Screws (index 47) from Booster or Oscillator (index 46). Remove Booster or Oscillator and o-ring (index 45).
 - b. For models with a 4"ANSI 150 / DN100 PN16 flange installed on side B, loosen (2) screws (index 69) using a 5/32" male hex wrench (Allen wrench) until two-piece clamp can move freely. Next, unscrew flange (index 74) from assembly.
 - c. For all models without a Booster or Oscillator, remove (8) Socket Head Cap Screws (index 68) from Side B Outlet Adapter (index 61 through 67) using a 5/16" male hex wrench (Allen wrench). Remove Side B Outlet and o-ring (index 60).

8.3.2 SIDE A MAIN VALVE SEAT

This procedure requires special tool TFAZ020 which may be purchased from Task Force Tips. Undamaged tools may be returned after use for a credit. This tool is used with a 1/2" drive breaker-bar or T-handle wrench and a short extension. Referring to index numbers shown in sections 6.1, follow the steps below:

1. Close upstream water supply and relieve pressure leading up to HUM. Remove monitor, booster, or oscillator if desired per 7.2.1.
2. The HUM inlet flange must be disconnected to replace the side A valve seat. Ensure upstream water supply has been shut off. Disconnect any hoses or devices on C1 & C2 ports. Loosen and remove the (8) bolts or studs through the side A flange, then remove the HUM from the standpipe.
3. Using special tool TFAZ020, remove Valve Seat Retainer (index 1) from Flange (index 3).
4. Using pliers, pull old Valve Seat (index 2) out of groove in Flange.
5. Using soap and water, clean all surfaces of Half Ball (index [A]), Flange and Valve Seat Retainer that contact the Valve Seat. Also clean all debris from threads of Valve Seat Retainer and Flange. Verify all sealing surfaces are smooth and intact. If significant damage is visible, consult Task Force Tips Service Department.
6. Apply light coat of silicone-based grease such as Dow Corning 112 to all sealing surfaces and threads of Half Ball, Flange, and Valve Seat Retainer. Open valve so Half Ball is out of the way.
7. Install new Valve Seat into groove in Flange with wider side facing the Half Ball. Slide a pick laterally between female thread and Valve Seat to verify entire circumference of Valve Seat is seated in groove.
8. Install Valve Seat Retainer into Flange until it is snug against the Valve Seat. When the Retainer stops moving and a significant increase in effort is needed to move it further, stop tightening.
9. Reinstall valve according to instructions in section 4.0. Close the side A main valve, open the side B monitor valve, then restore the water supply to the HUM.
10. Rotate the side A main valve crank handle approximately 1 full turn counter-clockwise to bleed air out of the standpipe.
11. When the water level raises above the side A main valve seat, close the side A main valve.
12. Wait for the majority of water in the HUM body to exit through the external drain valve (index 15 through 20). If leakage is observed past the Valve Seat, try tightening the Valve Seat Retainer slightly more. If leaking does not stop, consult Task Force Tips Service Department.
13. Reinstall monitor, booster, or oscillator according to instructions in section 4.0

8.2.3 SIDE B MONITOR VALVE SEAT

This procedure requires special tool TFAZ019 which may be purchased from Task Force Tips. Undamaged tools may be returned after use for a credit. This tool is used with a ½” drive breaker-bar or T-handle wrench and a short extension. Referring to index numbers shown in sections 6.1, follow the steps below:

1. Close upstream water supply and relieve pressure leading up to HUM. Remove monitor, oscillator, or booster per 7.2.1.
2. Using special tool TFAZ019, remove Inner Valve Seat Retainer (index 41).
3. Using pliers, pull old Valve Seat (index 40) out of groove in Outer Valve Seat Retainer (index 7).
4. Using soap and water, clean all surfaces of Half Ball (index [B]), Outer Retainer (index 6) and Inner Retainer (index 41) that contact the Valve Seat. Also clean all debris from threads of the Outer and Inner Retainers. Verify all sealing surfaces are smooth and intact. If significant damage is visible, consult Task Force Tips Service Department.
5. Apply light coat of silicone based grease such as Dow Corning 112 to all sealing surfaces and threads of Half Ball, the Outer Retainer and Inner Retainer. Open valve so Half Ball is out of the way.
6. Install new Valve Seat into groove in the Outer Retainer with wider side facing the Half Ball. Slide a pick laterally between female thread and valve seat to verify entire circumference of Valve Seat is seated in groove.
7. Install Valve Seat Retainer into Flange until it is snug against the Valve Seat. When the Retainer stops moving and a significant increase in effort is needed to move it further, stop tightening.
8. Start with both valves in the closed position. Rotate the side A main valve crank handle approximately 1 full turn counterclockwise and the side B monitor valve crank handle approximately 2 full turns clockwise to bleed air out of the standpipe and HUM.
9. When water level raises above the side B valve seat, close the side B monitor valve. Verify that the side B valve seat does not leak. It will be helpful to soak up excess water with a sponge or absorbent cloth, for a clear view of any leaks. If leakage is observed, try tightening the valve seat retainer slightly more. If leaking does not stop, consult Task Force Tips Service Department.
10. Reinstall monitor, booster, or oscillator according to instructions in section 4.0.

9.0 PRESSURE LOSS

The flow coefficients in table 8.1 and curves in figure 8.2 represent all models of the Hydrant Under Monitor for several possible usage scenarios. This data is estimated from the Side A inlet flange to the designated outlet of the HUM only and does not include pressure losses of any downstream equipment such as monitors, nozzles and hoses. The Cv flow coefficients in table 8.1 apply for water use only, and are calculated according to the formula:

$$C_v = \frac{Q}{\sqrt{\Delta P}} \quad \text{Where } C_v = \text{flow coefficient, } Q = \text{flow rate in gpm, and } \Delta P = \text{pressure loss in psi across valve}$$

To calculate pressure loss for a given flow rate through each port, this formula can be rearranged as
$$\Delta P = \frac{Q^2}{C_v^2}$$

NOTICE

Downstream connections can highly influence the flow rate through each outlet of the HUM. When a pump is attached downstream of any of the HUM outlets, care must be taken to avoid starving flow to any outlets that are not connected to the same pump. The data in table 8.1 and figure 8.2 assume that all ports are either discharging to the atmosphere with no downstream pumps, or that all ports are attached to the same downstream pump. This data is not valid if separate pumps are connected to each outlet, or if some outlets have pumps connected while others do not. Independent testing is recommended to ensure the entire system meets performance requirements.

SCENARIO	Flow versus pressure loss curves for approximate ranges A through G are shown in figure 8.2						
	A (Cv = 250)	B (Cv = 375)	C (Cv = 500)	D (Cv = 625)	E (Cv = 750)	F (Cv = 875)	G (Cv = 1000)
Side B Monitor			Side B Cv=550				
C1 with 6" Storz							Port C1 Cv=1010
C1 w/ 5" Storz or 4.5" to 6" male threads					Port C1 Cv=750		
C1 w/ 4" Storz or 3.5" to 4" male threads			Port C1 Cv=460				
C1 w/ 2.5" male threads or gated wye (loss per port)	Port C1 Cv=240						
C2 w/ any 3.5" to 5" connection			Port C2 Cv=490				
C2 w/ 2.5" male threads or gated wye (loss per port)	Port C2 Cv=260						
C1 w/ 6" Storz & C2 w/ any 3.5" to 5" connection		Port C2 Cv=335				Port C1 Cv=890	
C1 & C2 w/ 5" Storz on both ports		Port C2 Cv=355			Port C1 Cv=700		
C1 & C2 w/ 2.5" male threads or gated wyes	C1/ C2 Cv=220						
Side B Monitor & C1 w/ 6" Storz			Side B Cv=550			Port C1 Cv=890	
Side B Monitor & C1 w/ 5" Storz or 4.5" to 6" male			Side B Cv=550	Port C1 Cv=660			
Side B Monitor & C1 w/ 2.5" gated wye	Port C2 Cv=220		Side B Cv=550				
Side B Monitor & C2 w/ 5" Storz		Port C2 Cv=380	Side B Cv=525				
Side B Monitor & C2 w/ 2.5" gated wye	Port C2 Cv=220		Side B Cv=525				
Side B Monitor, C1 w/ 6" Storz & C2 w/ 5" Storz	Port C2 Cv=250		Side B Cv=480		Port C1 Cv=740		
Side B, C1 & C2 w/ 2.5" gated wyes on both ports	C1/ C2 Cv=200		Side B Cv=550				

Table 8.1: Estimated flow coefficients for various scenarios, with HUM outlets used either independently or simultaneously

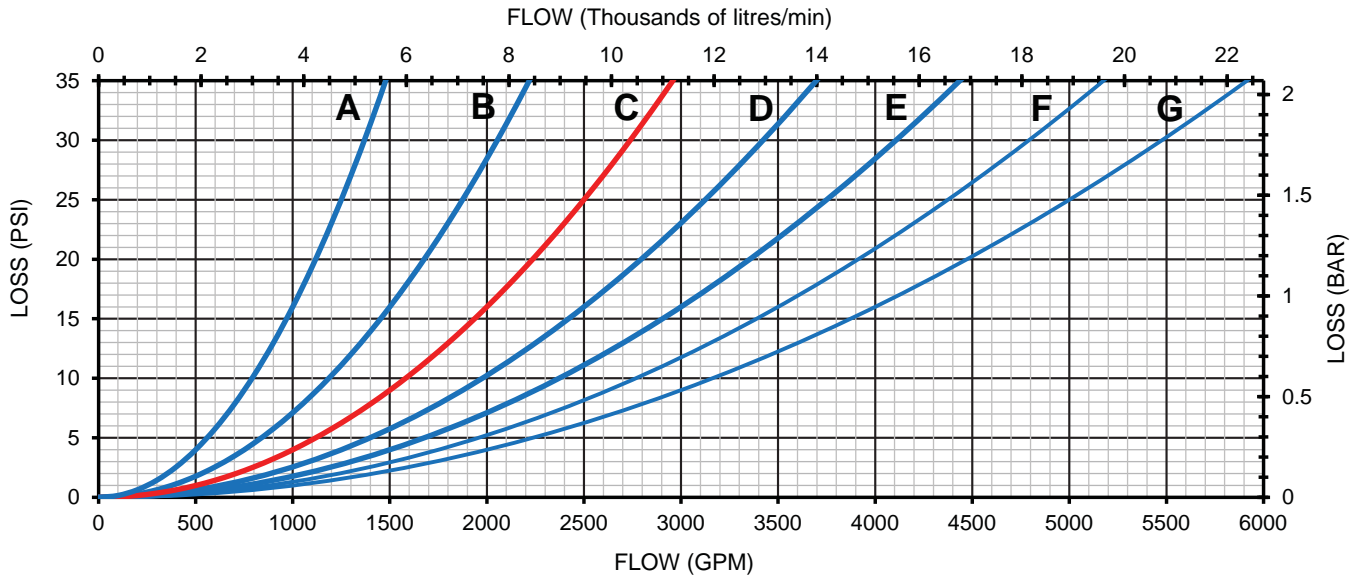

For Side B monitor (curve C), do not exceed the following flow rates at specified nozzle inlet pressures:

- 2500 gpm below 130 psi (9500 l/min @ 9 bar)
- 2000 gpm below 200 psi (8000 l/min @ 14 bar)
- 1600 gpm below 300 psi (6000 l/min @ 14 bar)

Figure 8.2: Flow rate versus pressure loss curves for the approximate ranges A through G from table 8.1.

10.0 ANSWERS TO YOUR QUESTIONS

We appreciate the opportunity of serving you and making your job easier. If you have any problems or questions, our toll-free "Hydraulics Hotline", 800-348-2686, is normally available to you 24 hours a day, 7 days a week.

11.0 WARRANTY

Task Force Tips, Inc., 3701 Innovation Way, Valparaiso, Indiana 46383-9327 ("TFT") warrants to the original purchaser of its Hydrant Under Monitor ("equipment"), and to anyone to whom it is transferred, that the equipment shall be free from defects in material and workmanship during the five (5) year period from the date of purchase.

TFT's obligation under this warranty is specifically limited to replacing or repairing the equipment (or its parts) which are shown by TFT's examination to be in a defective condition attributable to TFT. To qualify for this limited warranty, the claimant must return the equipment to TFT, at 3701 Innovation Way, Valparaiso, Indiana 46383-9327, within a reasonable time after discovery of the defect. TFT will examine the equipment. If TFT determines that there is a defect attributable to it, TFT will correct the problem within a reasonable time. If the equipment is covered by this limited warranty, TFT will assume the expenses of repair.

If any defect attributable to TFT under this limited warranty cannot be reasonably cured by repair or replacement, TFT may elect to refund the purchase price of the equipment, less reasonable depreciation, in complete discharge of its obligations under this limited warranty. If TFT makes this election, claimant shall return the equipment to TFT free and clear of any liens and encumbrances.

This is a limited warranty. The original purchaser of the equipment, any person to whom it is transferred, and any person who is an intended or unintended beneficiary of the equipment, shall not be entitled to recover from TFT any consequential or incidental damages for injury to person and/or property resulting from any defective equipment manufactured or assembled by TFT. It is agreed and understood that the price stated for the equipment is in part consideration for limiting TFT's liability. Some states do not allow the exclusion or limitation of incidental or consequential damages, so the above may not apply to you.

TFT shall have no obligation under this limited warranty if the equipment is, or has been, misused or neglected (including failure to provide reasonable maintenance) or if there have been accidents to the equipment or if it has been repaired or altered by someone else.

THIS IS A LIMITED EXPRESS WARRANTY ONLY. TFT EXPRESSLY DISCLAIMS WITH RESPECT TO THE EQUIPMENT ALL IMPLIED WARRANTIES OF MERCHANTABILITY AND ALL IMPLIED WARRANTIES OF FITNESS FOR A PARTICULAR PURPOSE. THERE IS NO WARRANTY OF ANY NATURE MADE BY TFT BEYOND THAT STATED IN THIS DOCUMENT.

This limited warranty gives you specific legal rights, and you may also have other rights which vary from state to state.