



4.5" Quick Connect Inlets for Elbows and Monitors

*Supplemental Instructions for use with Monitor Manuals
Compatible with Monsoon, Typhoon, and Hurricane Monitors*

INSTRUCTION FOR INSTALLATION, OPERATION, AND MAINTENANCE

⚠ DANGER

Understand manual before use. Operation of this device without understanding the manual and receiving proper training is a misuse of this equipment. Obtain safety information at tft.com/serial-number.

This equipment is intended for use by trained and qualified emergency services personnel for firefighting. All personnel using this equipment shall have completed a course of education approved by the Authority Having Jurisdiction (AHJ).

This instruction manual is intended to familiarize firefighters and maintenance personnel with the operation, servicing, and safety procedures associated with this product. This manual should be kept available to all operating and maintenance personnel.

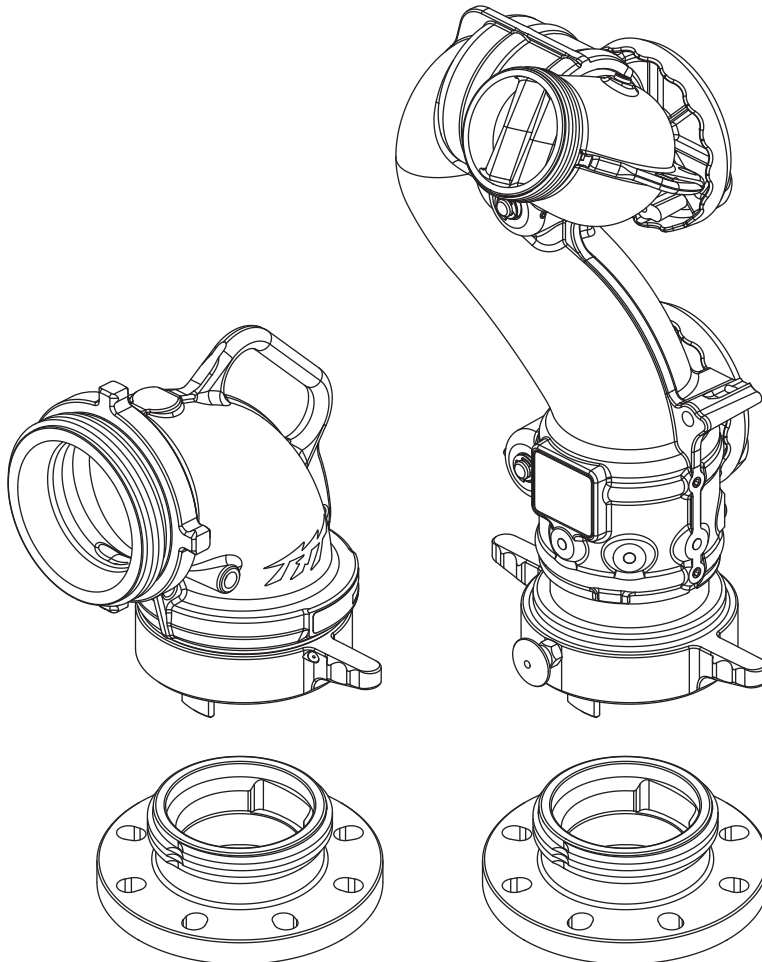

TASK FORCE TIPS LLC
MADE IN USA · tft.com

3701 Innovation Way, Valparaiso, IN 46383-9327 USA
800-348-2686 · 219-462-6161 · Fax 219-464-7155

TABLE OF CONTENTS

- 1.0 MEANING OF SAFETY SIGNAL WORDS
- 2.0 SAFETY
- 3.0 GENERAL INFORMATION
 - 3.1 SPECIFICATIONS
 - 3.2 USE WITH SALT WATER
- 4.0 INSTALLATION
 - 4.1 STRUCTURAL REQUIREMENTS
 - 4.2 INLET ADAPTER MOUNTING
- 5.0 OPERATING INSTRUCTIONS
 - 5.1 QUICK CONNECT MONITORS
 - 5.2 QUICK CONNECT ELBOWS
- 6.0 WARRANTY
- 7.0 MAINTENANCE
 - 7.1 SERVICE TESTING
 - 7.2 REPAIR
- 8.0 EXPLODED VIEWS AND PARTS LISTS

DANGER

PERSONAL RESPONSIBILITY CODE

The member companies of FEMSA that provide emergency response equipment and services want responders to know and understand the following:

1. Firefighting and Emergency Response are inherently dangerous activities requiring proper training in their hazards and the use of extreme caution at all times.
2. **IT IS YOUR RESPONSIBILITY** to read and understand any user's instructions, including purpose and limitations, provided with any piece of equipment you may be called on to use.
3. **IT IS YOUR RESPONSIBILITY** to know that you have been properly trained in Firefighting and/or Emergency Response and in the use, precautions, and care of any equipment you may be called upon to use.
4. **IT IS YOUR RESPONSIBILITY** to be in proper physical condition and to maintain the personal skill level required to operate any equipment you may be called upon to use.
5. **IT IS YOUR RESPONSIBILITY** to know that your equipment is in operable condition and has been maintained in accordance with the manufacturer's instructions.
6. Failure to follow these guidelines may result in death, burns or other severe injury.



Fire and Emergency Manufacturers and Service Association, Inc.
PO Box 147, Lynnfield, MA 01940 • www.FEMSA.org

© 2020 FEMSA. All Rights Reserved.

SUPPORTING MATERIALS

The following documents contain supporting safety and operating information pertaining to the equipment described in this manual.

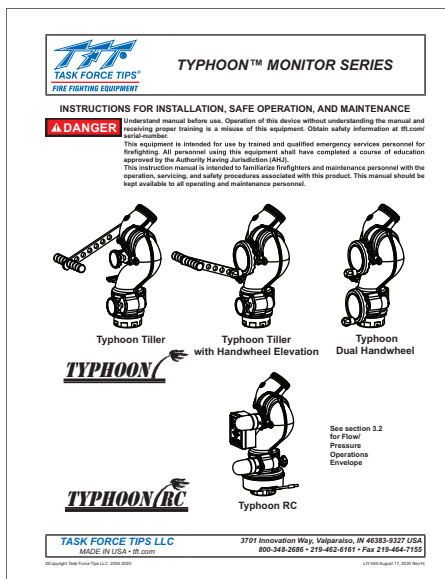

LIY-050 Typhoon Monitor Manual

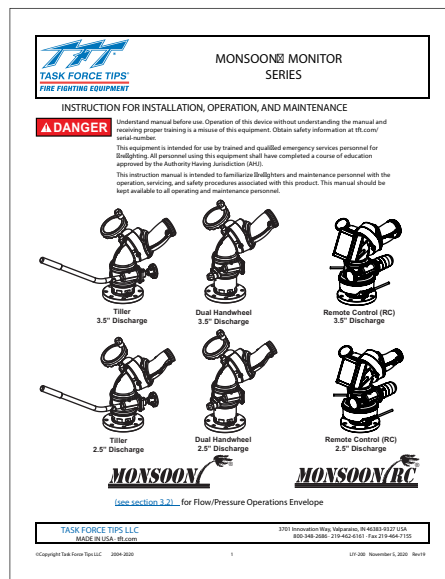

LIY-200 Monsoon Monitor Manual

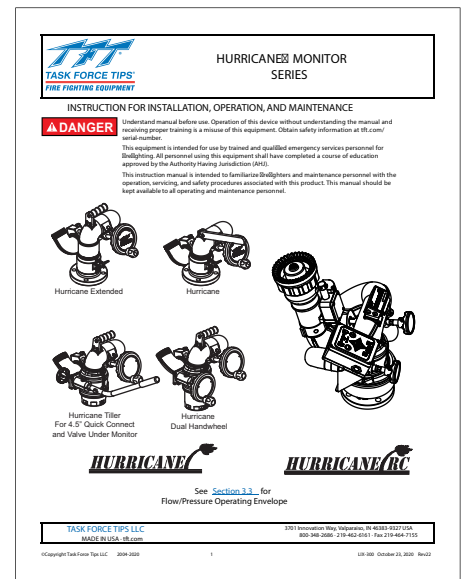

LIX-300 Hurricane Monitor Manual

1.0 MEANING OF SAFETY SIGNAL WORDS

A safety related message is identified by a safety alert symbol and a signal word to indicate the level of risk involved with a particular hazard. Per ANSI Z535.6, the definitions of the four signal words are as follows:



DANGER indicates a hazardous situation which, if not avoided, will result in death or serious injury.



WARNING indicates a hazardous situation which, if not avoided, could result in death or serious injury.



CAUTION indicates a potentially hazardous situation which, if not avoided, could result in minor or moderate injury.



NOTICE is used to address practices not related to physical injury.

2.0 SAFETY



An inadequate supply of pressure and/or flow will cause an ineffective stream and can result in injury or death. Choose operating conditions to deliver adequate fire suppression. See flow graphs.



This equipment is intended for use by trained personnel for firefighting. Use of this equipment for other purposes may involve hazards not addressed by this manual. Seek appropriate guidance and training to reduce risk of injury.



The stream exiting a nozzle is very powerful and capable of causing injury and property damage. Make sure the nozzle is securely attached and pointing in a safe direction before water is turned on. Do not direct water stream to cause injury or damage to persons or property.



Equipment may be damaged if frozen while containing significant amounts of water. Such damage may be difficult to detect visually. Subsequent pressurization can lead to injury or death. Any time the equipment is subject to possible damage due to freezing, it must be tested and approved for use by qualified personnel before being considered safe for use.

3.0 GENERAL INFORMATION

The 4.5" Quick Connect allows a monitor or elbow to be quickly and easily installed, removed and replaced. Applications include front bumper mounts for tilt-cab chassis maintenance, and sharing monitors between multiple standpipes. A ratcheting pull pin prevents loosening of 4.5"NH threads due to vibration. The elbow may be used to supply a fire pump in lieu of a hydrant.

Maximum operating pressure for elbow is 300 psi (20 bar), with a hydrostatic proof test pressure of 900 psi (62 bar). See monitor instruction manuals for maximum operating pressure of Monsoon, Typhoon, and Hurricane series monitors.

3.1 SPECIFICATIONS

	US	METRIC
Monitor Height Increase* vs. model without Quick Connect	0.3 - 3.2"	0.7 - 8.1 cm
Monitor Weight Increase* vs. model without Quick Connect	3.9 - 6.7 lb	1.8 - 3.0 kg
Elbow Dimensions** with 5" Storz	12.3 x 8.6 x 12.3"	31 x 21 x 31 cm
Elbow Weight** with 5" Storz	13.7 lb	6.21 kg
Operating Temperature Range of Fluid	33°F to 120°F	1°C to 50°C
Storage Temperature Range	-40 to 150°F	-40 to 65°C
Materials	Hardcoat anodized and powder coated aluminum, 316 Stainless Steel, Nylon, Nitrile rubber	

* Monitor specifications assume same inlet adapter is installed for comparison.

** Elbow specifications do not include inlet adapter and vary by outlet coupling.

See LOT-022 Price List and Product Specifications for details of each inlet adapter option.

Table 3.1

3.2 USE WITH SALT WATER

Use with salt water is permissible provided the equipment is thoroughly cleaned with fresh water after each use. The service life of the equipment may be shortened due to the effects of corrosion, and is not covered under warranty.

4.0 INSTALLATION

4.1 STRUCTURAL REQUIREMENTS

⚠ WARNING

Reaction forces generated by master stream flows are capable of causing injury and property damage if not properly supported. Monitors should be securely installed by qualified individuals.

- Mounting objects must be capable of withstanding maximum nozzle reaction force.
- The monitor must be securely mounted to rigid support members.
- Do not use flanges or pipe made from plastic for monitor mounting.
- Torque all fasteners to specified values.

The structure that the monitor is mounted to must withstand the internal pressure of the monitor as well as shear and bending forces due to nozzle reaction. Nozzle reaction can be as high as 1500 lbs (700 kg)(2000 gpm at 200 psi).

For flanged connections, the use of flat flanges without raised faces is recommended. Use a ring gasket as defined in ASME 16.21 or ISO 7483. Tighten flange bolts in an alternating sequence as shown below. Tighten sequentially each bolt or stud three times to 30%, then 60%, and finally 100% of the specified torque. Tighten to a total of 76-80 ft-lb (100-110 N·m).

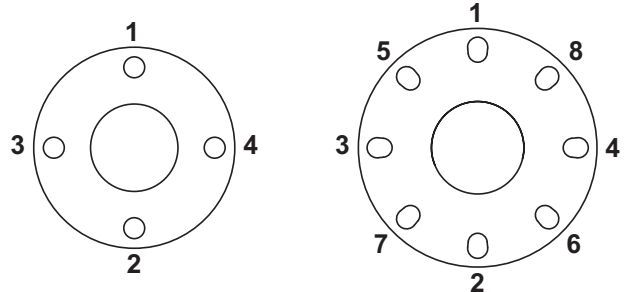

Tighten Sequentially Each Bolt Three Times
to a Total of 76-80 ft-lb (100-110 N·m)

⚠ WARNING

Reaction forces generated by master stream flows are capable of causing injury and property damage if not properly supported. Monitors should be securely installed by qualified individuals.

- Mounting objects must be capable of withstanding maximum nozzle reaction force.
- The monitor must be securely mounted to rigid support members.
- Do not use flanges or pipe made from plastic for monitor mounting.
- Torque all fasteners to specified values.

4.2 INLET ADAPTER MOUNTING

Various Inlet Adapters can be used for 4.5" Quick Connect Monitors and Elbows. These Inlet Adapters must be oriented upon installation for the monitor to point in the desired direction. Figure 4.2 shows examples of Inlet Adapters and the location of a "Straight Ahead Reference Mark" recessed into the threads. In the case of the VUM, the hex head trunnion between ports C2 and C3 serves as the Straight Ahead Reference Mark.

Travel ranges relative to the Straight Ahead Reference Mark can be modified by using Stop Bolts, which are used to limit the travel. See instruction manual for monitor for use of Stop Bolts.

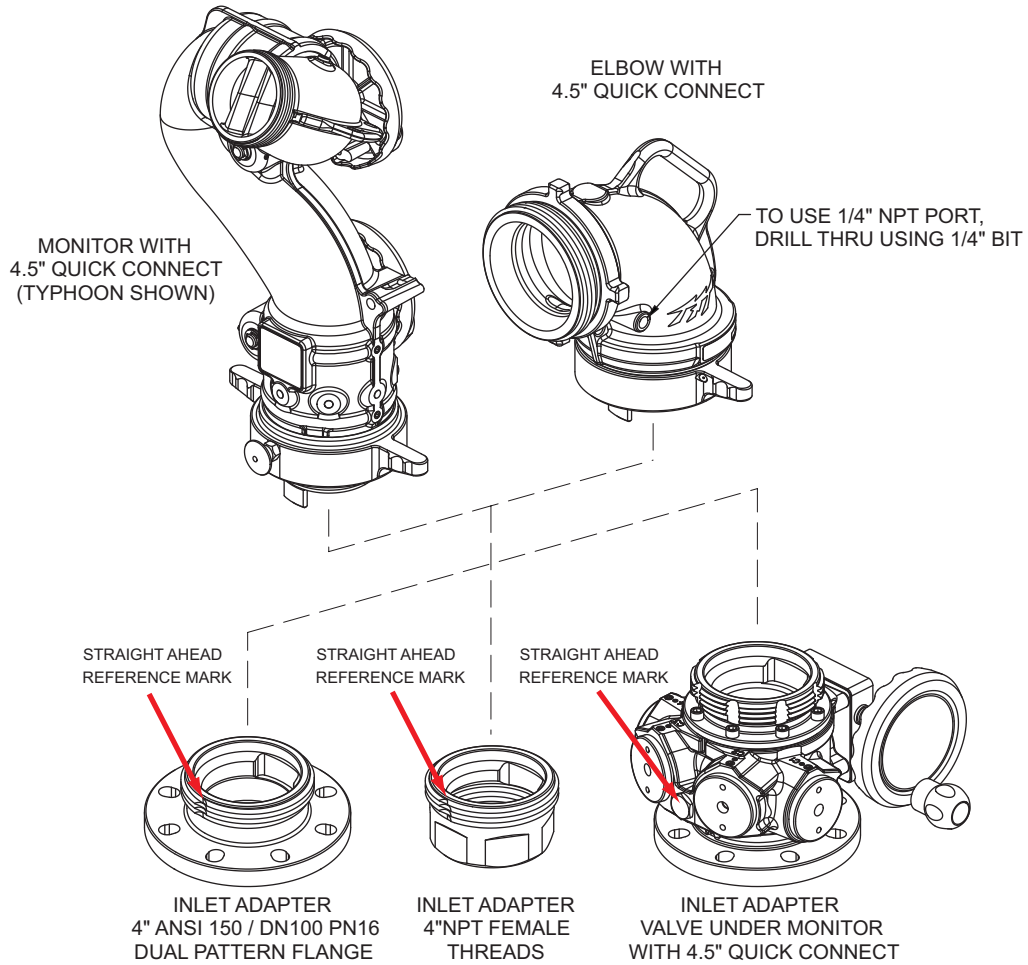

Figure 4.2

5.0 OPERATING INSTRUCTIONS

5.1 QUICK CONNECT MONITORS

TO INSTALL MONITOR ON INLET ADAPTER:

1. Hold locking pin out. Push coupling up as far as it will go, then release locking pin. This will hold the coupling out of the way while mounting the monitor onto inlet base.
2. Align the narrow tongue on the monitor inlet with straight ahead reference mark on the inlet adapter, then slide into inlet adapter.
3. Hold locking pin out. Rotate coupling clockwise until threads engage on inlet adapter, then release locking pin.
4. Continue to rotate coupling until tight. Locking pin will ratchet across detents, but it is not necessary to over-tighten coupling if locking pin ends up between detent positions. To prevent damage, do not use locking pin as a lever to tighten or loosen coupling.

TO REMOVE MONITOR FROM INLET ADAPTER:

1. Hold locking pin out. Rotate coupling counter-clockwise at least a half-turn to clear the detents, then release locking pin.
2. Continue to rotate coupling until threads are no longer engaged.
3. Lift the monitor out of the inlet adapter.

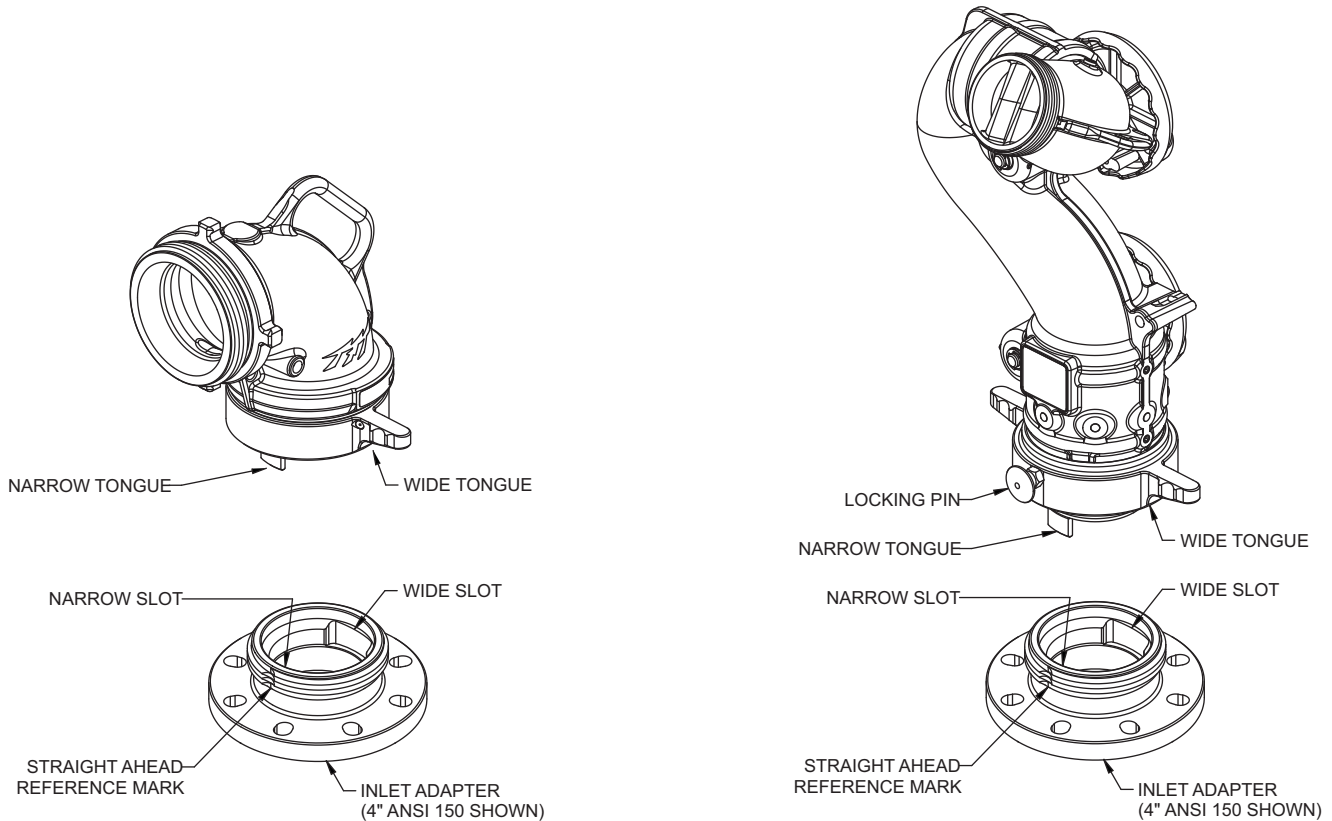

Figure 5.1

5.2 QUICK CONNECT ELBOWS

Elbow is intended for temporary installation only, so a locking pin is not needed. ([see Figure 5.1](#))

The full time swivel joint and tongues engaged into slots are able to prevent accidental disassembly due to forces acting on the hose line. If desired, a 1/4" NPT pressure gage may be installed in the elbow by drilling thru the blind port shown in section 4.2 using a 1/4" drill bit.

TO INSTALL ELBOW ON INLET ADAPTER:

1. Align narrow tongue on the inlet elbow with straight ahead reference mark in the inlet adapter, then slide into inlet adapter.
2. Rotate coupling clockwise until tight.

TO REMOVE ELBOW FROM INLET ADAPTER:

1. Rotate coupling counter-clockwise until threads are no longer engaged.
2. Lift the elbow out of the inlet adapter.

6.0 WARRANTY

Go to tft.com for all warranty information.

7.0 MAINTENANCE

TFT products are designed and manufactured to be damage resistant and require minimal maintenance. However, as the primary firefighting tool upon which your life depends, it should be treated accordingly. The unit should be kept clean and free of dirt by rinsing with water after each use. Any inoperable or damaged parts should be repaired or replaced before placing the unit in service. To help prevent mechanical damage, do not drop or throw equipment.

In applications where appliances are left continuously connected to the apparatus or other devices or are used where water is trapped inside the appliance, the appliance must be flushed with fresh water following each use and inspected for damage.

This appliance should be disconnected, cleaned and visually inspected inside and out at least quarterly, or as water quality and use may require. Moving parts such as handles, valve ball and couplings should be checked for smooth and free operation. Seals shall be greased as needed with Silicone based grease such as Molykote 112. Any scrapes that expose bare aluminum should be cleaned and touched up with enamel paint such as Rust-Oleum. Replace any missing or damaged parts before returning to service.

Any equipment taken out of service due to failure should be returned to the factory for repair or replacement. If you have any questions regarding the testing or maintenance of your valve, please call Task Force Tips at 800-348-2686.

7.1 SERVICE TESTING

In accordance with NFPA 1930, equipment must be tested a minimum of annually. Units failing any part of this test must be removed from service, repaired and retested upon completion of the repair.

7.2 REPAIR

Factory service is available. Factory serviced equipment is repaired by experienced technicians, wet tested to original specifications, and promptly returned. Call TFT service department at 1-800-348-2686 to troubleshoot and, if needed, directions for return. A return for service form can also be obtained at tft.com/Support/Returning-an-Item-for-Service.

Repair parts and service procedures are available for those wishing to perform their own repairs. Task Force Tips assumes no liability for damage to equipment or injury to personnel that is a result of user service. Contact the factory or visit the web site at tft.com for parts lists, exploded views, test procedures and troubleshooting guides.

Performance tests shall be conducted on the equipment after a repair, or anytime a problem is reported to verify operation in accordance with TFT test procedures. Consult factory for the procedure that corresponds to the model and serial number of the equipment. Any equipment which fails the related test criteria should be removed from service immediately. Troubleshooting guides are available with each test procedure or equipment can be returned to the factory for service and testing.



It is the responsibility of service technicians to ensure the use of appropriate protective clothing and equipment. The chosen protective clothing and equipment must provide protection from potential hazards users may encounter while servicing equipment. Requirements for protective clothing and equipment are determined by the Authority Having Jurisdiction (AHJ).



Any alterations to the product or its markings could diminish safety and constitutes a misuse of this product.



All replacement parts must be obtained from the manufacturer to assure proper performance and operation of the device.

8.0 EXPLODED VIEWS AND PARTS LISTS

Exploded views and parts lists are available at tft.com/serial-number.