

# HEMISPHERE™ Transportable Monitor

## INSTRUCTIONS FOR INSTALLATION, OPERATION, AND MAINTENANCE

**⚠ DANGER**

Understand manual before use. Operation of this device without understanding the manual and receiving proper training is a misuse of this equipment. Obtain safety information at [tft.com/serial-number](http://tft.com/serial-number)

This equipment is intended for use by trained and qualified emergency services personnel for firefighting. All personnel using this equipment shall have completed a course of education approved by the Authority Having Jurisdiction (AHJ).

This instruction manual is intended to familiarize firefighters and maintenance personnel with the operation, servicing, and safety procedures associated with this product. This manual should be kept available to all operating and maintenance personnel.

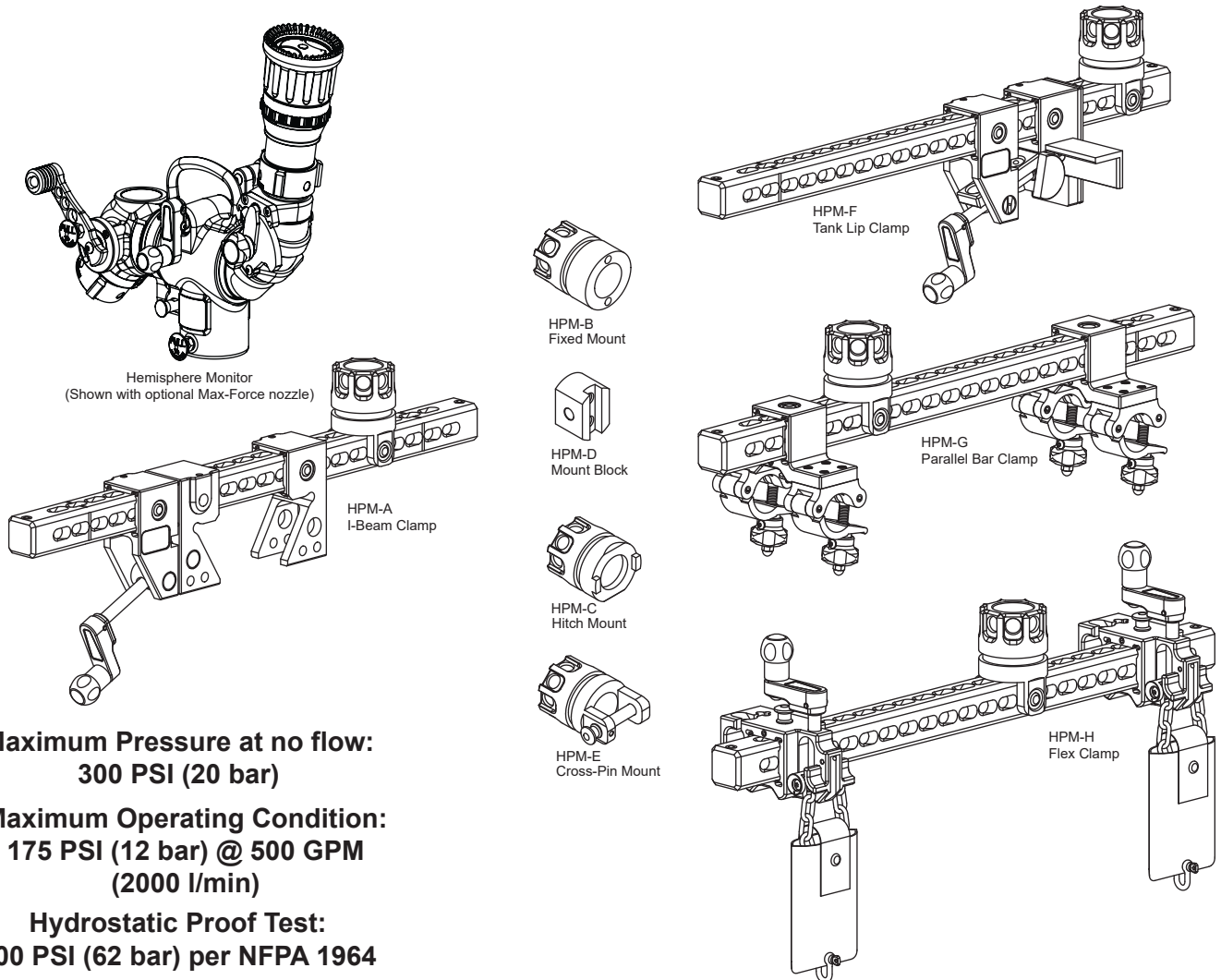

**Maximum Pressure at no flow:  
 300 PSI (20 bar)**

**Maximum Operating Condition:  
 175 PSI (12 bar) @ 500 GPM  
 (2000 l/min)**

**Hydrostatic Proof Test:  
 900 PSI (62 bar) per NFPA 1964**

# ⚠ DANGER

## PERSONAL RESPONSIBILITY CODE

The member companies of FEMSA that provide emergency response equipment and services want responders to know and understand the following:

1. Firefighting and Emergency Response are inherently dangerous activities requiring proper training in their hazards and the use of extreme caution at all times.
2. It is your responsibility to read and understand any user's instructions, including purpose and limitations, provided with any piece of equipment you may be called upon to use.
3. It is your responsibility to know that you have been properly trained in Firefighting and /or Emergency Response and in the use, precautions, and care of any equipment you may be called upon to use.
4. It is your responsibility to be in proper physical condition and to maintain the personal skill level required to operate any equipment you may be called upon to use.
5. It is your responsibility to know that your equipment is in operable condition and has been maintained in accordance with the manufacturer's instructions.
6. Failure to follow these guidelines may result in death, burns or other severe injury.



Fire and Emergency Manufacturers and Service Association  
 P.O. Box 147, Lynnfield, MA 01940 • www.FEMSA.org

## SUPPORTING MATERIALS

The following documents contain supporting safety and operating information pertaining to the equipment described in this manual.

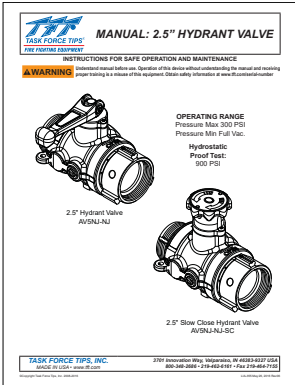

LIA-355 2.5" Hydrant Valve

# Table Of Contents

1.0 MEANING OF SAFETY SIGNAL WORDS	5.0 OPERATING INSTRUCTIONS
2.0 SAFETY	5.1 INSTALLING THE MONITOR ONTO THE MOUNT
3.0 GENERAL INFORMATION	5.2 RELEASING THE MONITOR FROM THE MOUNT
3.1 SPECIFICATIONS	5.3 PRESSURE GAUGE PORT
3.2 SAFE OPERATING ENVELOPE	5.4 ROTATING THE MONITOR ABOUT THE MOUNT
3.3 USE WITH SALT WATER	5.4.3 ROTATIONAL LOCK SAFELY MECHANISM
3.4 VARIOUS MODELS AND TERMS	5.5 HEMISPHERE COVERAGE
3.4.1 HEMISPHERE TRANSPORTABLE MONITOR	5.5.1 POINTING THE NOZZLE
3.4.2 I-BEAM CLAMP/2" HITCH MOUNT (HPM-A)	5.5.2 PIVOTING THE OUTLET
3.4.3 TANK LIP CLAMP (HPM-F)	5.5.3 ROTATING THE WATERWAY
3.4.4 PARALLEL BAR CLAMP (HPM-G)	5.5.4 QUARTER TURN VALVE
3.4.5 FLEX CLAMP (HPM-H)	6.0 FLOW CHARACTERISTICS
4.0 INSTALLING CLAMPS AND MOUNTS	6.1 HEMISPHERE PRESSURE LOSS
4.1 I-BEAM CLAMP (HPM-A)	6.2 AUTOMATIC, FIXED, AND SELECTABLE FLOW NOZZLES
4.1.1 MAXIMUM FLANGE DIMENSIONS	6.3 STACKED TIPS AND SMOOTH BORE NOZZLES
4.1.2 INSTALLING THE I-BEAM CLAMP	6.4 STREAM STRAIGHTENERS
4.2 2" HITCH RECEIVER MOUNT	7.0 USE WITH FOAM
4.3 HITCH MOUNT (HPM-C)	8.0 WARRANTY
4.4 FIXED MOUNT (HPM-B)	9.0 MAINTENANCE
4.5 MOUNTING BLOCK (HPM-D)	9.0.1 DOUBLE BALL PIVOT SYNCHRONIZER AND LOCK MAINTENANCE
4.6 CROSS PIN MOUNT (HPM-E)	9.0.2 LOCK PIN ASSEMBLY MAINTENANCE
4.7 TANK LIP CLAMP (HPM-F)	9.1 SERVICE TESTING
4.7.1 TANK LIP CLAMP ASSEMBLY	9.2 REPAIR
4.7.2 INSTALLING THE TANK LIP CLAMP	10.0 EXPLODED VIEWS AND PARTS LISTS
4.8 PARALLEL BAR CLAMP (HPM-G)	11.0 OPERATION AND INSPECTION CHECKLIST
4.8.1 INSTALLING THE PARALLEL BAR CLAMP	
4.9 FLEX CLAMP (HPM-H)	
4.9.1 CHAIN SAFETY	
4.9.1.1 CHAIN BENDING	
4.9.1.2 MINIMUM BEND RADIUS REQUIREMENT	
4.9.1.3 CHAIN AND SHACKLE INSPECTION	
4.9.1.4 ADDING CHAIN FOR LARGER OBJECTS	
4.9.1.5 CHAIN POSITIONING	
4.9.2 INSTALLING THE FLEX CLAMP	

## 1.0 MEANING OF SAFETY SIGNAL WORDS

A safety related message is identified by a safety alert symbol and a signal word to indicate the level of risk involved with a particular hazard. Per ANSI Z535.6, the definitions of the four signal words are as follows:

**⚠ DANGER**

**DANGER** indicates a hazardous situation which, if not avoided, will result in death or serious injury.

**⚠ WARNING**

**WARNING** indicates a hazardous situation which, if not avoided, may result in death or serious injury.

**⚠ CAUTION**

**CAUTION** indicates a potentially hazardous situation which, if not avoided, could result in minor or moderate injury.

**NOTICE**

**NOTICE** is used to address practices not related to physical injury.

## 2.0 SAFETY

**⚠ DANGER**

An inadequate supply of pressure and/or flow will cause an ineffective stream and can result in injury or death. Choose operating conditions to deliver adequate fire suppression. See flow graphs.

**⚠ WARNING**

Sudden change in position of an improperly secured monitor can result in an out of control monitor. An out of control monitor can spray water in unintended directions or become a projectile, causing serious injury or death. To reduce the risk of an out of control monitor:

- Carefully select structural members for monitor mounting which are capable of safely supporting reaction forces, torque, hose load, and vibration, under maximum flow conditions
- Verify the mount and monitor are correctly positioned and securely installed
- Do not attempt to remove the monitor from its clamp or mounting block while flowing
- Do not attempt to re-position the monitor on its 8-position mount while flowing
- Do not attempt to readjust the I-beam clamp while flowing

In the event of an out of control monitor:

- Immediately retreat to a safe distance
- Shut down the water hose at its source before attempting to re-secure the monitor

**⚠ WARNING**

Interrupting flow to the monitor could cause injury or death. Avoid situations that may interrupt flow to the monitor such as hose line kinks, traffic running over hose, and automatic doors or devices that can pinch the hose.

**⚠ WARNING**

The stream exiting a nozzle is very powerful and capable of causing injury and property damage. Make sure the nozzle is securely attached and pointing in a safe direction before water is turned on. Do not direct water stream to cause injury or damage to persons or property.

**⚠ WARNING**

Equipment may be damaged if frozen while containing significant amounts of water. Such damage may be difficult to detect visually. Subsequent pressurization can lead to injury or death. Any time the equipment is subject to possible damage due to freezing, it must be tested and approved for use by qualified personnel before being considered safe for use.

**⚠ CAUTION**

Mismatched or damaged waterway connections may cause equipment to leak or uncouple under pressure. Failure could result in injury. Equipment must be mated to matched connections.

**⚠ CAUTION**

Dissimilar metals coupled together can cause galvanic corrosion that can result in the inability to uncouple the connection, or complete loss of engagement over time. Failure could cause injury. Per NFPA 1962, if dissimilar metals are left coupled together, an anti-corrosive lubricant should be applied to the connection and the coupling should be disconnected and inspected at least quarterly.

**NOTICE**

To prevent mechanical damage, do not drop or throw equipment.

### 3.0 GENERAL INFORMATION

The Hemisphere is a versatile, lightweight, and easy to deploy transportable monitor that gives the user the ability to quickly establish water flow in locations that ground monitors cannot. Since the Hemisphere doesn't rely on gravity for stability, it can be pointed horizontal and down, in addition to up, unlike portable ground monitors. The rotating, pivoting waterway, allows the stream to be directed in virtually any direction, within a hemispherical range, without interrupting water flow. A variety of mounts, including an I-beam clamp that doubles as a 2" receiver hitch mount, a dedicated hitch mount, and fixed mounts, provide the user the ability to quickly attach the monitor, and establish coverage on the fire ground, or in preplanned locations. An integrated, quarter turn, hardcoat anodized aluminum half ball valve, with locking bail handle, provides shutoff capability. The main and valve bodies are hardcoat anodized aluminum inside and out, with a blue TFT powder coat finish on the outside.

### 3.1 SPECIFICATIONS

Size (without nozzle, I-beam clamp, or mounts)	25.5"L x 8.1"W x 10"H	(650mm x 210mm x 260mm)
Weight (without nozzle, I-beam clamp, or mounts)	22 lbs	(10 kg)
Maximum monitor inlet pressure with valve shut off	300 psi	(20 bar)
Operating temperature of fluid	33 to 120°F	(1 to 50°C)
Storage temperature range	-40 to 150°F	(-40 to 65°C)
Standard Inlet Coupling	2 1/2" NH Female	
Standard Outlet	2 1/2" NH Male	
Mounting Positions	8 positions, every 45° (shutdown to reposition)	
Double Ball Pivot Sweep	80° (while flowing)	
Main Waterway Rotation	360° (while flowing)	
Hose Approach	45° inlet valve rotates 360°	
Materials used	Aluminum 6000 series hard anodized MIL8625 class 3 type 2, stainless steel 300 series, nylon 6-6	

Table 3.1

### 3.2 SAFE OPERATING ENVELOPE

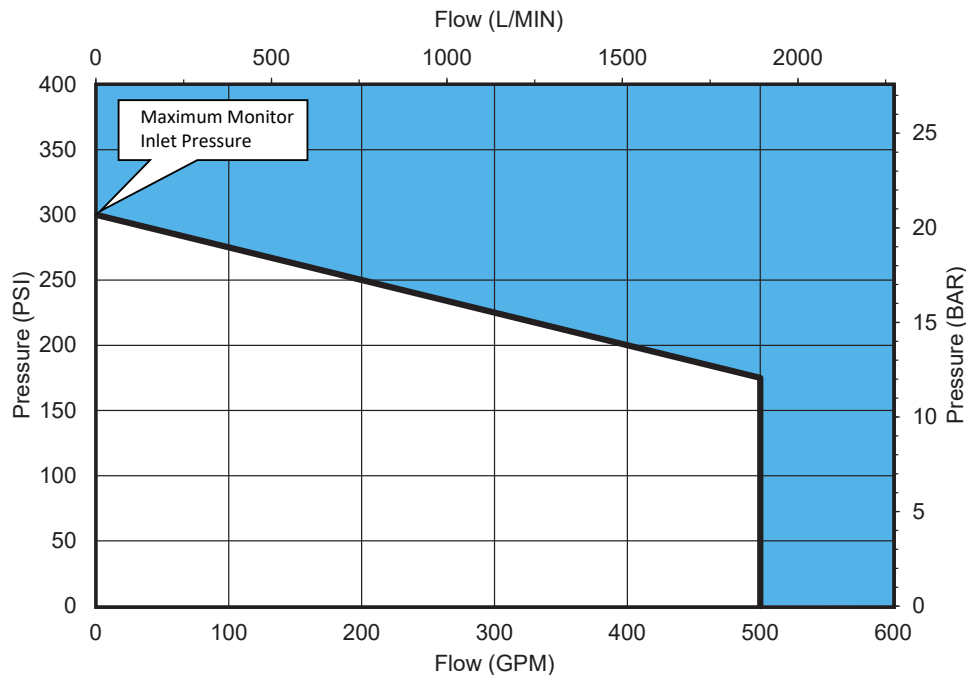

Figure 3.2  
Hemisphere Monitor Safe Operating Envelope

### 3.3 USE WITH SALT WATER

Use with salt water is permissible provided the equipment is thoroughly cleaned with fresh water after each use. The service life of the equipment may be shortened due to the effects of corrosion, and is not covered under warranty.

### 3.4 VARIOUS MODELS AND TERMS

The Hemisphere can be installed on a variety of mounts, each of which includes a standard profile for attaching the Hemisphere monitor. The following sections identify the various parts and controls on a standard Hemisphere transportable monitor, and available mounts.

#### 3.4.1 HEMISPHERE TRANSPORTABLE MONITOR

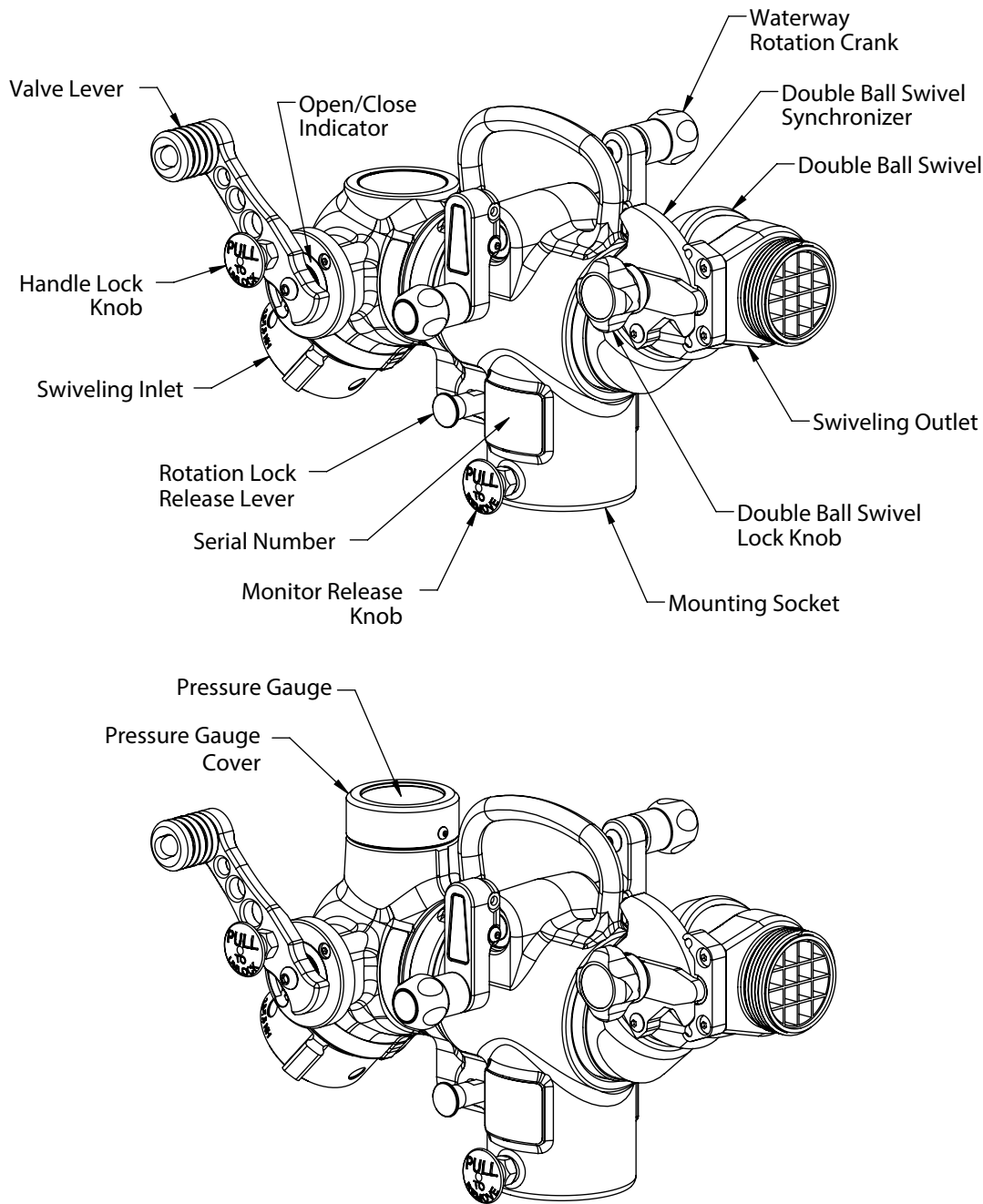

Figure 3.4.1  
Hemisphere Transportable Monitor

### 3.4.2 I-BEAM CLAMP/2" HITCH MOUNT (HPM-A)

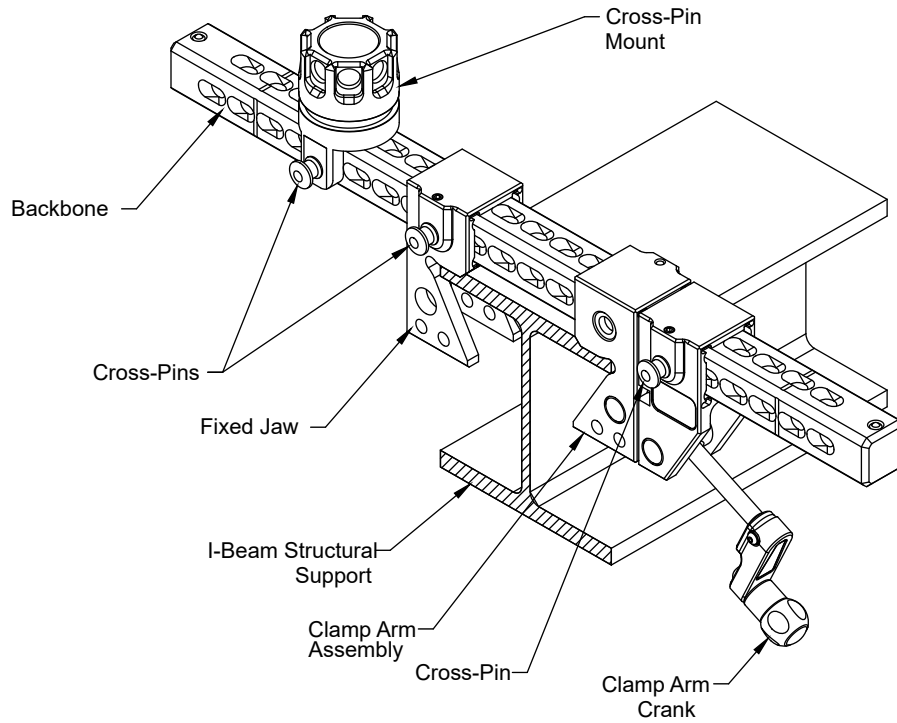

Figure 3.4.2  
I-Beam Clamp/2" Hitch Mount

### 3.4.3 TANK LIP CLAMP (HPM-F)

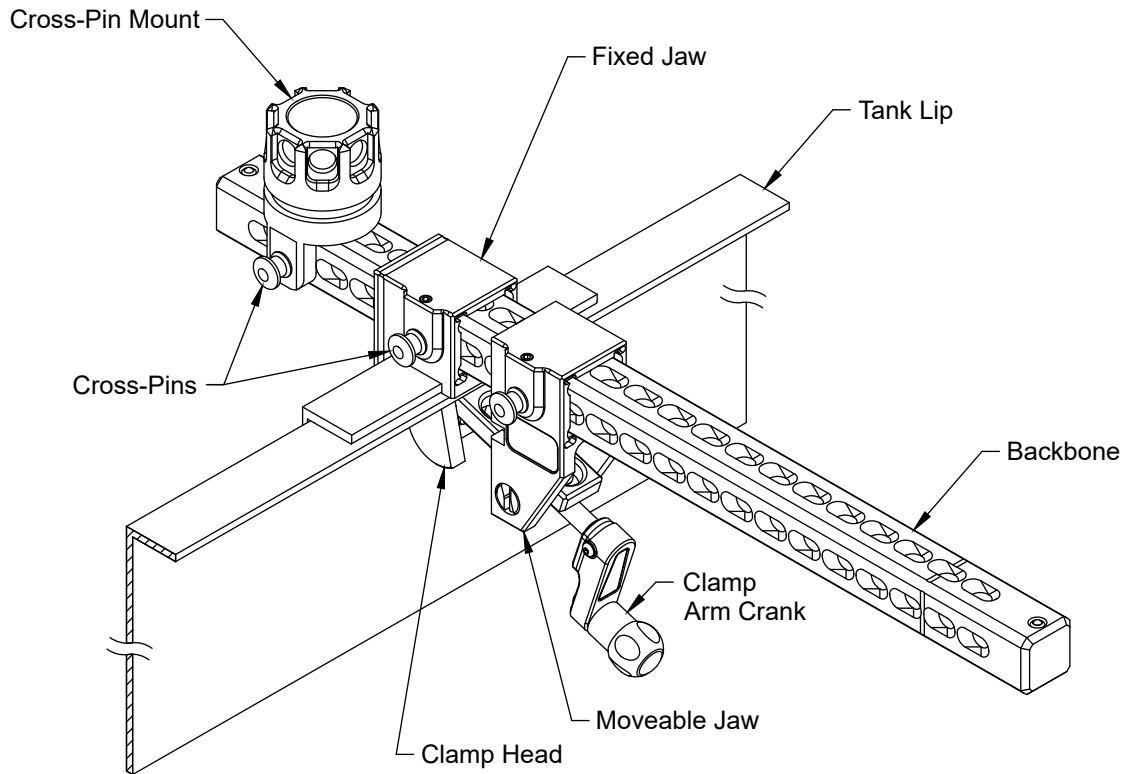

Figure 3.4.3  
Tank Lip Clamp

### 3.4.4 PARALLEL BAR CLAMP (HPM-G)

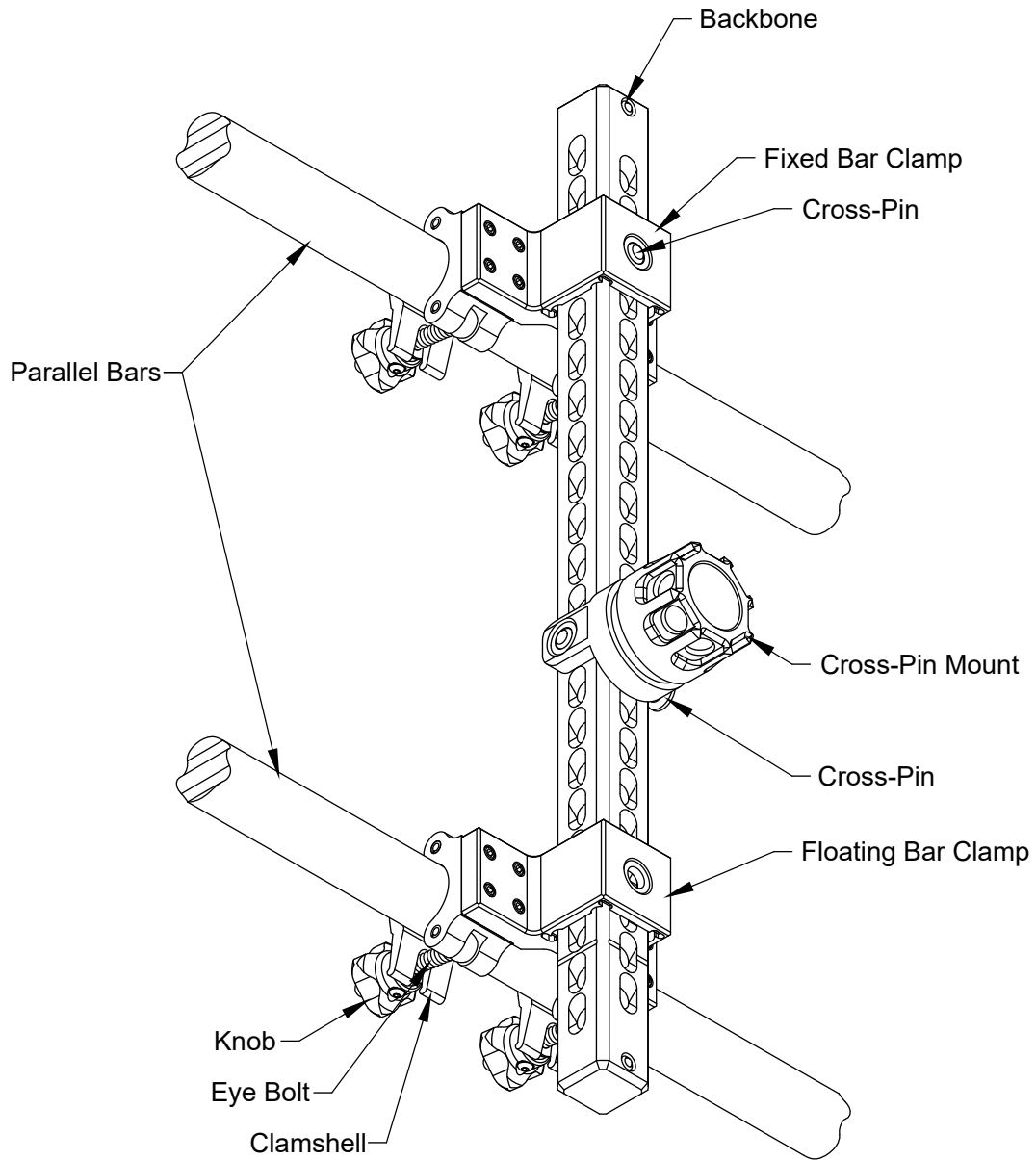

Figure 3.4.4  
Parallel Bar Clamp



### 3.4.5 FLEX CLAMP (HPM-H)

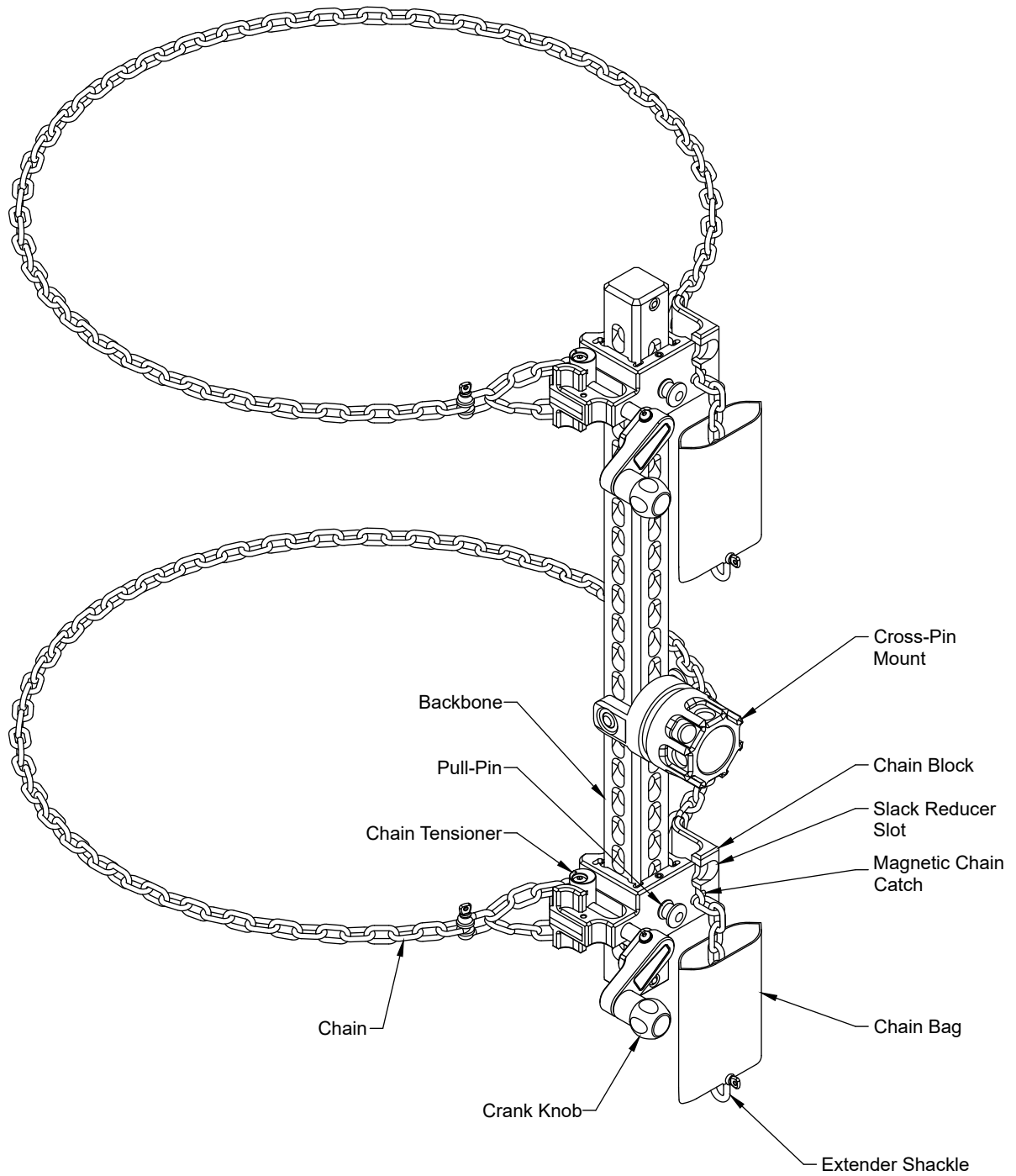

Figure 3.4.5  
Flex Clamp

## 4.0 INSTALLING CLAMPS AND MOUNTS

### ⚠️ WARNING

Monitor clamps and mounts installed on weak objects can become unstable causing an out of control monitor resulting in injury or death. Choose stationary objects capable of safely supporting monitor reaction force, torques, hose load, and vibration.

### ⚠️ CAUTION

Working from an elevated position involves increased risk of injury or property damage due to falling persons or equipment. To avoid fall or drop hazards:

- Use care when transporting, installing, and using the Hemisphere, its mounts, nozzle, and hose from an elevated position
- Select mount locations where there is no need to lean out beyond the confines of safety railings
- Wear proper fall protection gear as directed by the Authority Having Jurisdiction (AHJ)
- Avoid situations posing a drop hazard to persons below

The Hemisphere transportable monitor can be secured onto fixed mounts or to a backbone that can be attached to stationary objects using a series of different clamp types. The clamps are designed to restrain loads from only one monitor per backbone.

Clamp onto structures able to safely support loads from nozzle reaction force and weight loading. Loading includes weight of the monitor, inlet fittings, discharge fittings, nozzle, plus hose when charged with water.

Avoid clamping onto frangible materials like fireproofing, insulating layers, sheet metal, brickwork, eroded process pipes, or structurally compromised objects. The most reliable object is one that has been load tested under actual operating conditions.

### 4.1 I-BEAM CLAMP (HPM-A)

Before attaching to an I-beam or other suitable object, the clamp must be configured to position the monitor in relation to the clamped object. Plan the mounting position to give good clearance for the hose, room to operate the valve handle, and plenty of freedom to point the monitor where needed.

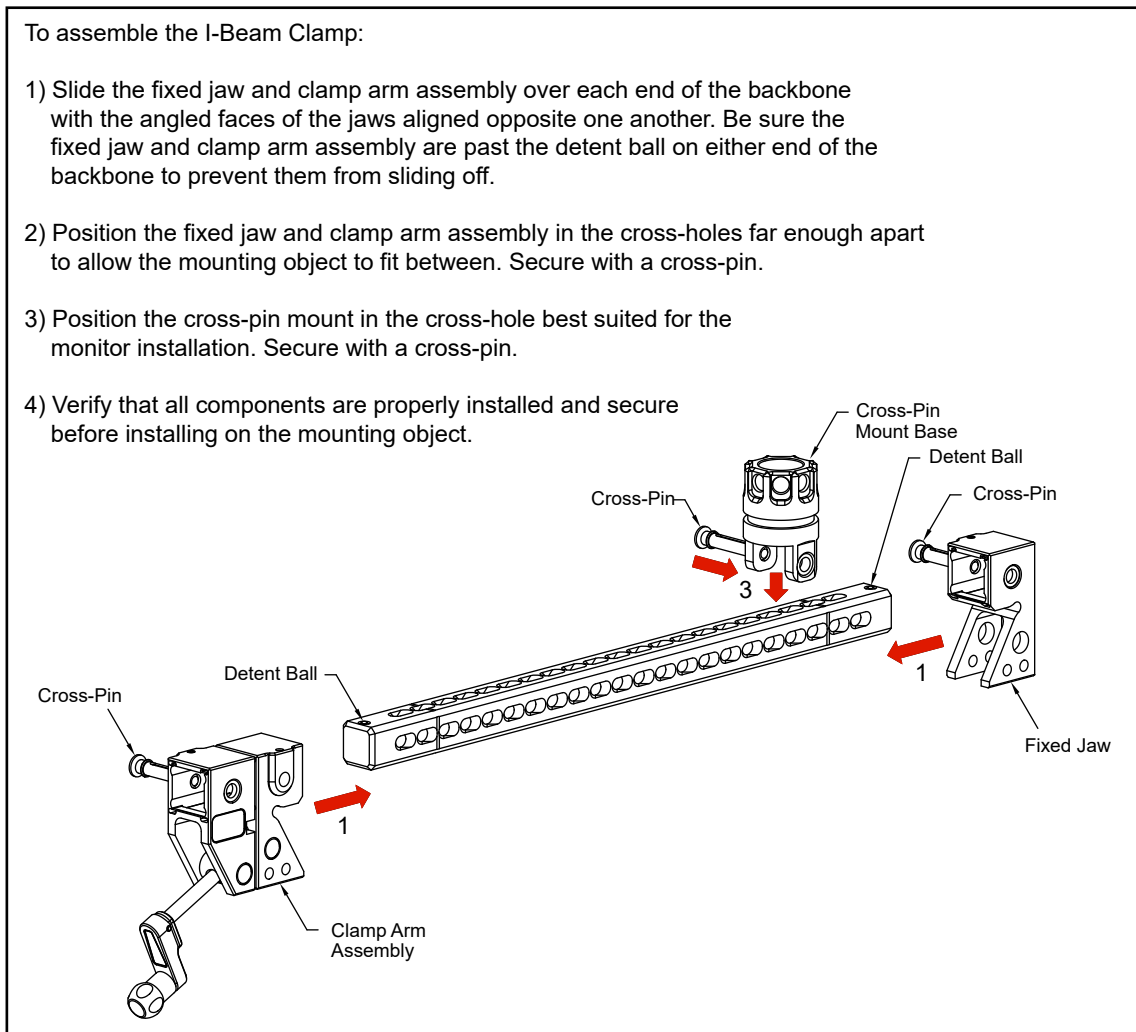

Figure 4.1  
I-Beam Clamp Assembly

### 4.1.1 MAXIMUM FLANGE DIMENSIONS

Figure 4.1.1A shows the maximum flange thickness and width to which the I-beam clamp is designed to attach. These dimensional maximums should not be exceeded. Parallel beams of round and angle cross-section (as would commonly be encountered on hand rails), or any other cross-sectional shapes, must not exceed these dimensions.

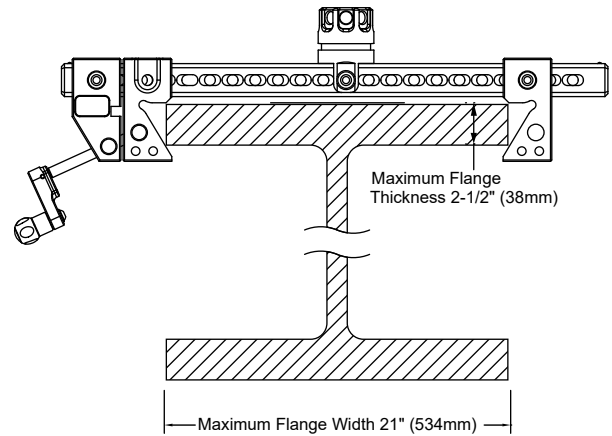

Figure 4.1.1A  
Maximum Flange Dimensions for Installing the I-Beam Clamp



**Exceeding the maximum flange dimensions will compromise the ability of the clamp to maintain a fixed position, resulting in an out of control monitor. To avoid injury, death, and/or property damage from an out of control monitor, do not install I-beam clamps on any flange with a thickness exceeding 2-1/2" (38 mm) or a width exceeding 21" (534 mm).**

Several orientations are possible when clamping to I-beams, stair rails, and other suitable geometry. Figure 4.1.1B shows some examples of possible orientations.

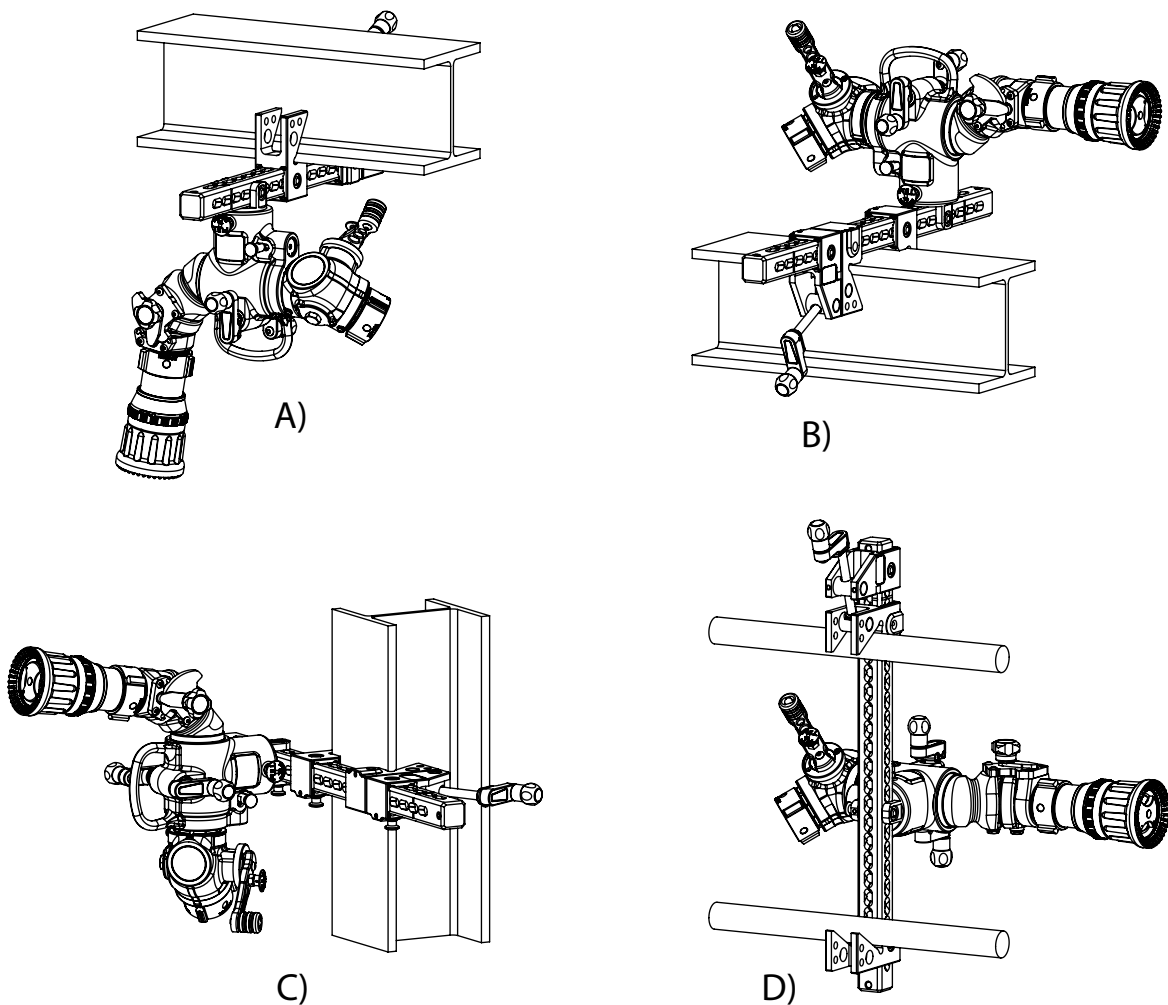

Figure 4.1.1B  
Examples of I-Beam Clamp Installation

## 4.1.2 INSTALLING THE I-BEAM CLAMP

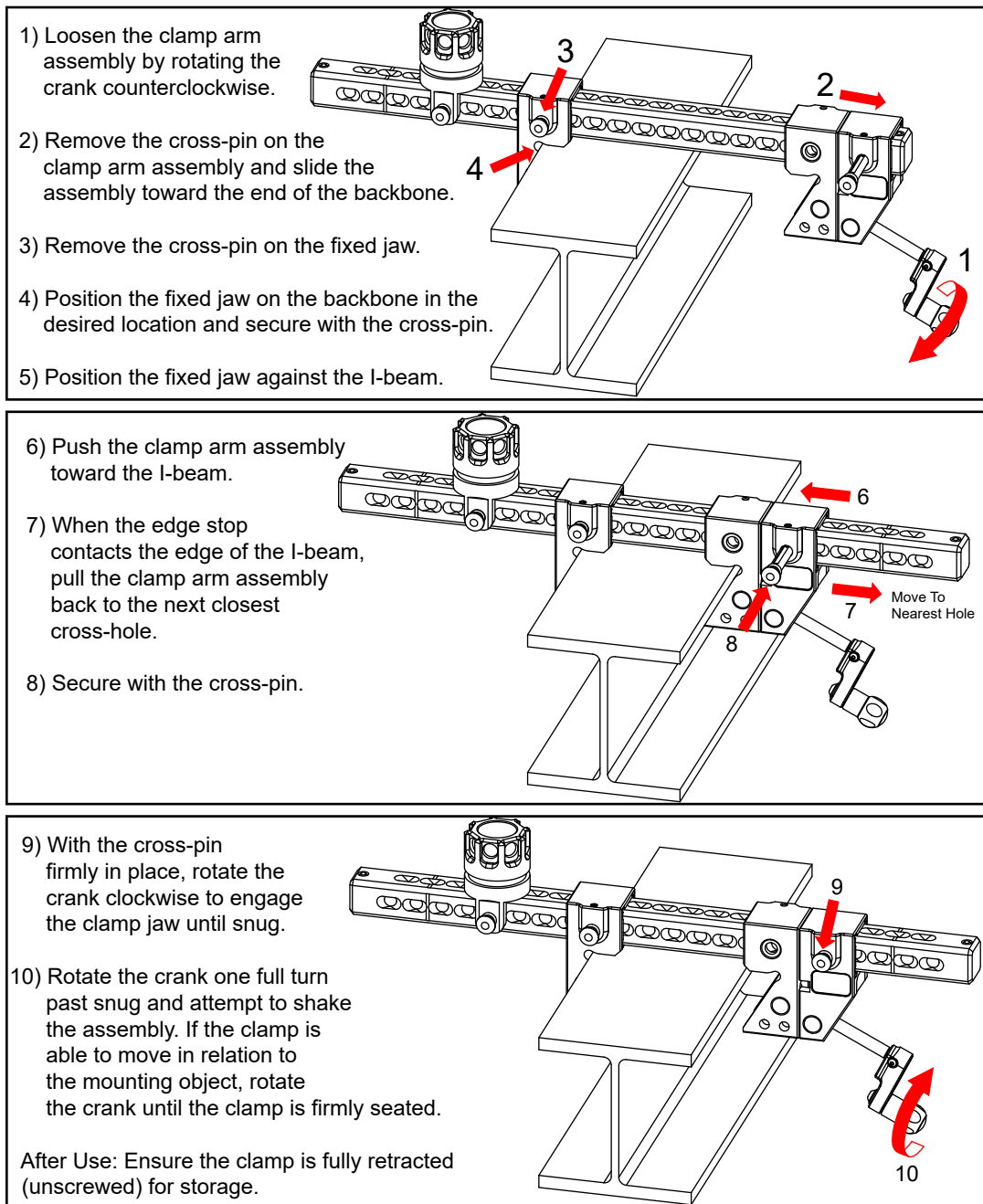

Figure 4.1  
Installing the I-Beam Clamp

### **⚠ WARNING**

Overtightening the I-beam clamp can distort or damage the clamp resulting in an insecure monitor mounting that will not safely support reaction forces. Don't turn crank more than one turn after the jaws are fully seated and crank arm has stopped moving. Don't tighten the crank with a wrench, tool, or cheater bar.

## 4.2 2" HITCH RECEIVER MOUNT

The 2" backbone for the I-beam clamp is sized to fit into any standard 2" x 2" Class III or Class IV hitch receiver.

- 1) Remove the 2 jaws from the I-beam assembly.
- 2) Slide the backbone into the hitch receiver and secure with a standard 5/8" (16mm) hitch pin. Use a cotter pin or some other retention device to retain the hitch pin.
- 3) Install the cross-pin mount on the backbone and secure with a cross-pin.

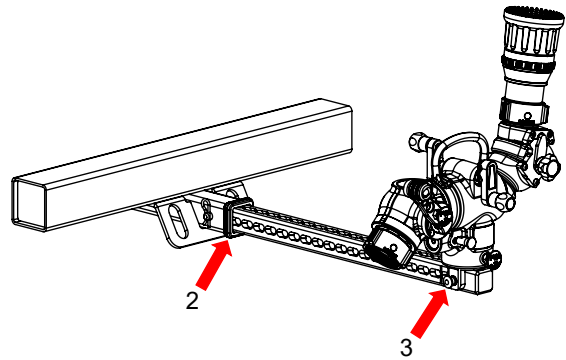

Figure 2.11 I-Beam Clamp Installation Step 4



**Unsecured monitors will move suddenly when flow is initiated and could cause injury or death. Cross pin must be installed and secured before charging hose and while flowing monitor.**

## 4.3 HITCH MOUNT (HPM-C)

The 2" Hitch Mount can be installed on a standard 2" class III trailer hitch. The mount can be inverted for access to the hitch ball for towing, provided there is sufficient clearance from the ground and other objects while towing.

- 1) Remove the hitch ball, nut, and lock washer from the hitch tongue.
- 2) Insert the hitch mount washer into the mount. Place the mount flush against the hitch tongue on the opposite side of the desired position of the ball.
- 3) Insert the hitch ball through the tongue and hitch mount washer.
- 4) Fasten the lock washer and nut to the hitch ball.
- 5) Slide the assembly into the hitch and secure with the hitch pin and cotter pin.

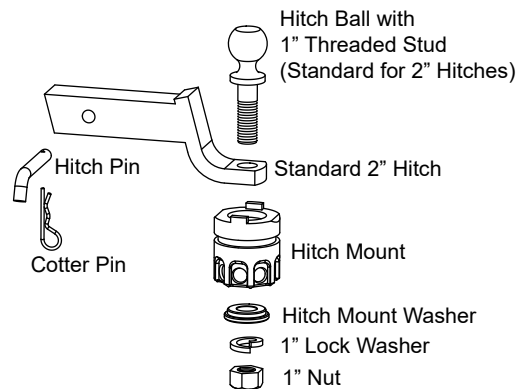

Figure 4.3  
Hitch Mount Assembly and Installation

**NOTICE**

**Using the hitch mount for anything other than mounting a monitor is a misuse of this product. Never attempt to tow or pull with the hitch mount.**

## 4.4 FIXED MOUNT (HPM-B)

### NOTICE

Select a mounting surface and fasteners able to support the weight of the monitor and all attachments, including the water contained within the monitor and hoses, and also the torque resulting from the reaction forces and hoses.

Fixed Mounts can be installed in preplanned locations for fast, precise setup.

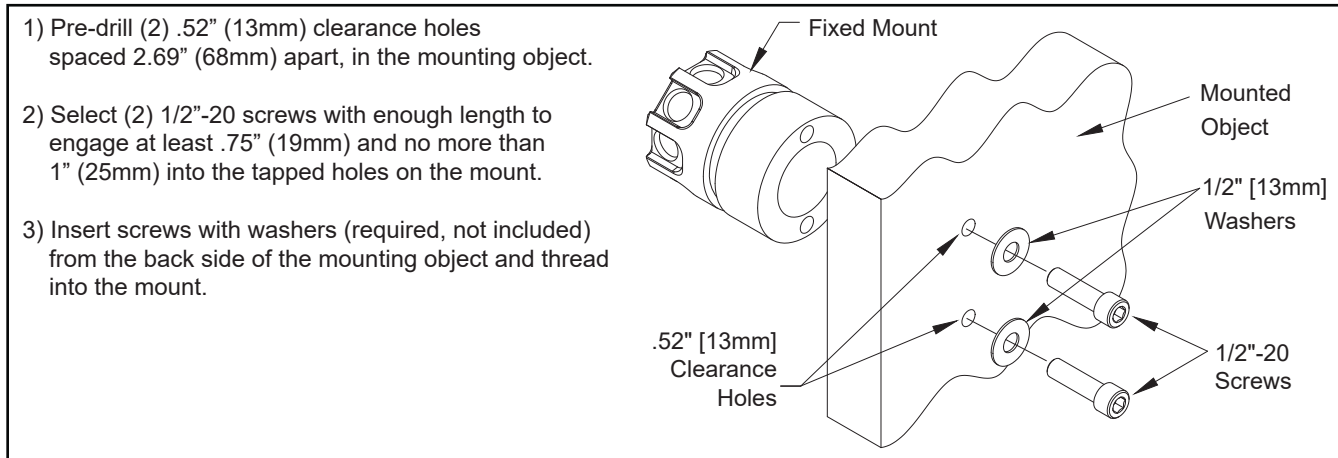

Figure 4.4  
Fixed Mount Installation

## 4.5 MOUNTING BLOCK (HPM-D)

The Mounting Block can be installed from the back or in locations where the back side of the mounting surface is inaccessible.

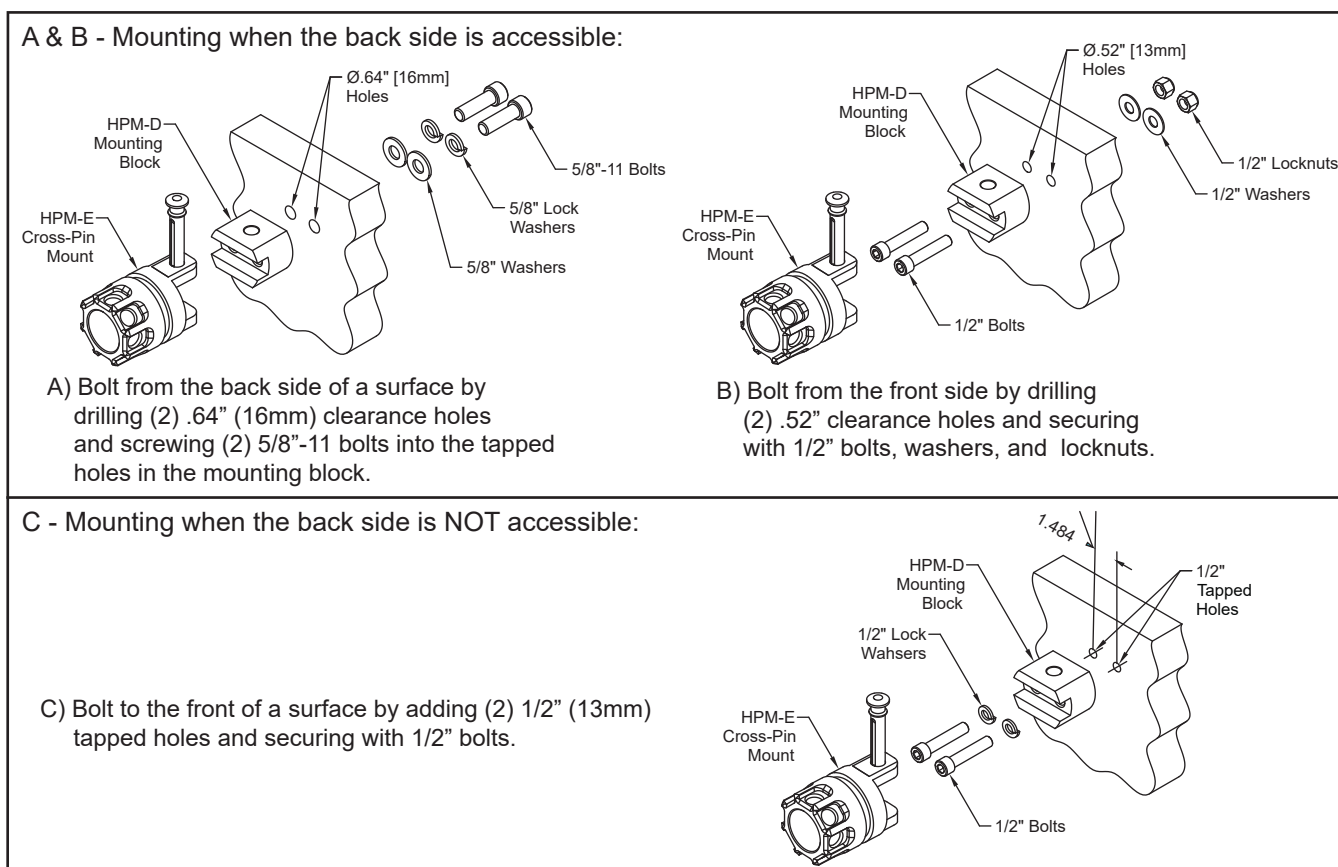

Figure 4.5  
Mounting Block Installation Options

## 4.6 CROSS PIN MOUNT (HPM-E)

A cross-pin mount can be added to a mounting block to create a monitor-ready attachment location. The same cross-pin mount and detented cross-pin included with the I-beam clamp/2" hitch mount is used for this purpose. Contact tft.com or your local dealer to order additional mounts as spare or replacement parts.

## 4.7 TANK LIP CLAMP (HPM-F)

The tank lip clamp is intended for use on floating roof tanks that are constructed in accordance with the API 650 2007 standard, with top angle stiffening rings between 2 1/2" x 2 1/2" x 1/4" to 4" x 4" x 1/2".

### 4.7.1 TANK LIP CLAMP ASSEMBLY

Before installing the clamp onto the tank lip, consideration should be given to the desired monitor position (inside or outside the tank), hose lay (hose should be supported as close to the monitor as possible to reduce the load created by the weight of the hose and water on the clamp and monitor), operator position, and the direction the stream will need to point. The monitor should be positioned as close to the clamp jaws as possible to reduce the torque imparted by the reaction force of the stream and the weight of the hose and the water within the hose on the clamp, and ultimately the tank lip itself. Too much torque can damage the clamp and/or the tank.

- 1) Install the cross-pin mount in the desired monitor location.
- 2) Turn the clamp arm crank counterclockwise to ensure it is fully retracted before installing on the tank.
- 3) Position the fixed jaw as close to the cross-pin mount as possible while allowing clearance for the monitor.
- 4) Pin the movable jaw in the closest to or next closest position to the fixed jaw depending on the top angle. If the jaws are pinned 3 holes apart, the clamp head will not engage the tank lip.

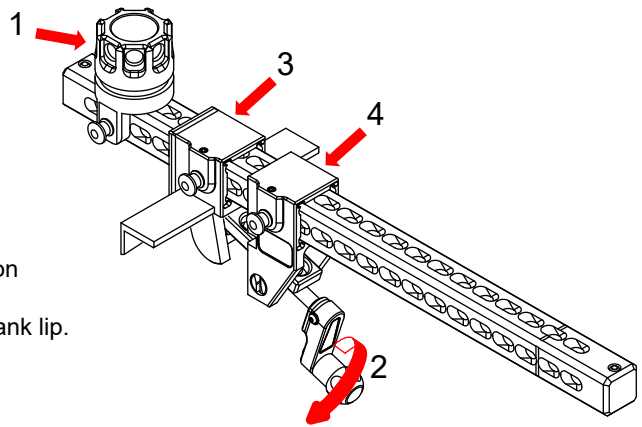

Figure 4.7.1  
Preparing the Tank Lip Clamp for Installation

### 4.7.2 INSTALLING THE TANK LIP CLAMP

- 1) With the jaws pinned in the desired positions, slide the assembly over the tank lip. Be careful not to drop the assembly into or off the side of the tank.
- 2) While holding the fixed jaw flush against the tank lip, rotate the crank clockwise until the clamp head is snug against the tank lip.
- 3) Rotate the crank an additional half-turn until tight.

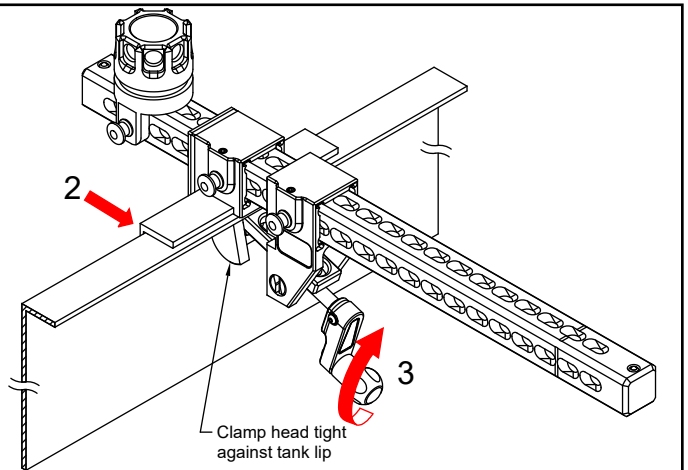

Figure 4.7.2  
Installing the Tank Lip Clamp

## 4.8 PARALLEL BAR CLAMP (HPM-G)

The parallel bar clamp is intended for use on a pair of round parallel bars between 1.5" and 2.0" diameter, spaced between 5" to 29" apart, on center.

### 4.8.1 INSTALLING THE PARALLEL BAR CLAMP

The parallel bar clamp is intended for use on a pair of round parallel bars between 1.5" and 2.0" diameter, spaced between 5" to 29" apart, on center. Care must be taken to ensure that the bars are strong enough, and have adequate support, to withstand the reaction force of the water, the weight of the monitor, clamp, hose, water, and any attachments. For example, an OSHA standard hand rail may only be required to support 200 lbs in any direction, while the reaction force alone created by this monitor can exceed 350 lbs.

1) Fully retract the 4 knobs by turning them counterclockwise until they have reached the travel stops.

2) Install the fixed bar clamp and secure with a cross-pin.

3) Install the fixed bar clamp by placing the clamshells over one of the parallel bars. Close the clamshells, latch the eye bolts over the arms, and turn the knobs clockwise until snug.

4) Slide the floating bar clamp into position over the second parallel bar. Close the clamshells, latch the eye bolts over the arms, and turn the knobs clockwise until snug.

5) Turn all four knobs an additional quarter turn to ensure they are snug.

6) Install the cross-pin mount in the desired position on the backbone. Allow clearance for the monitor. The cross-pin mount should be positioned either between the bars or as close to one of them as possible to minimize the amount of torque on the bars.

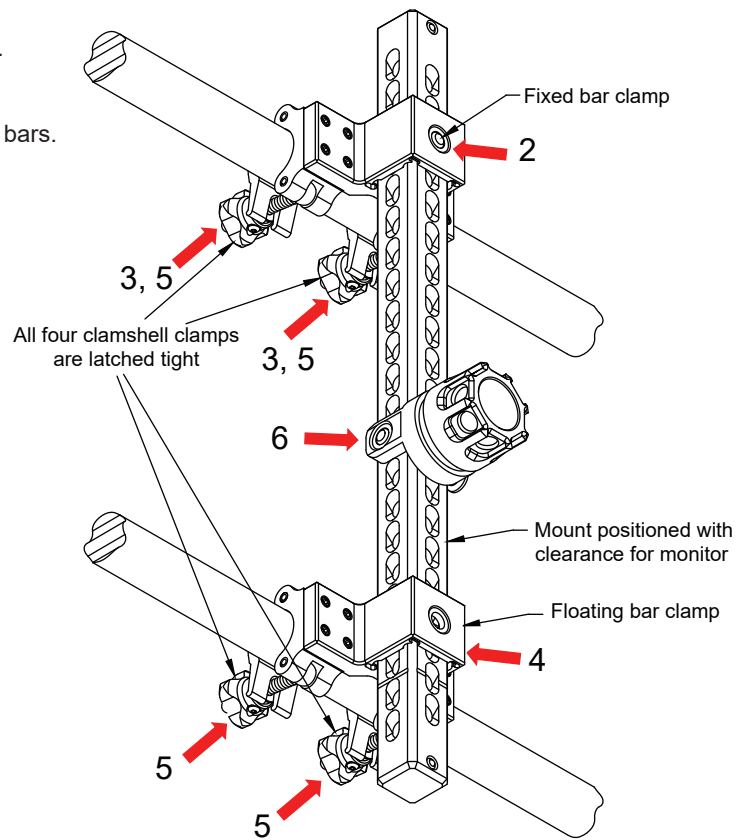

Figure 4.8.1  
Installing the Parallel Bar Clamp



## 4.9 FLEX CLAMP (HPM-H)

The flex clamp can be used on a variety of different objects. Round objects between 3" to up to 24" diameter can be attached to using the chain supplied with the unit. Larger diameter round objects can be attached to by adding additional chain. Objects with different shaped cross sections can be attached provided there are no sharp edges that the chain must lay against.

### 4.9.1 CHAIN SAFETY

#### **⚠️ WARNING**

Chain strength can be reduced when damaged or corroded. Degraded chain can break, causing property damage and/or injury.

- Inspect the chain and shackles before and after each use. Refer to CHAIN AND SHACKLE INSPECTION section for inspection criteria.
- Avoid installing chain on objects with sharp corners as this can bend the chain. Bent chain has less strength and could break, causing property damage and/or bodily harm. Refer to MINIMUM BEND RADIUS REQUIREMENT section for minimum radius gaging instructions.
- Avoid high temperatures which could reduce the safe working load of the chain and may result in an unsafe condition. If chain is exposed to temperatures of 400°F (204°C) or higher, remove the clamp from service and replace the chain.
- Never use a cheater bar or other such device to turn the chain tensioner crank. Using a cheater bar or other such device to turn the chain tensioner crank can damage the clamp. A damaged clamp can fail, causing property damage and/or injury.

#### 4.9.1.1 CHAIN BENDING

The chain will bend and be weakened if it is tightened against a sharp edge such as:

- An unprotected I-beam. (The I-beam clamp (HPM-A) should be used on unprotected I-beams.)
- L or C channel
- Square or rectangular bars with sharp corners
- Guard rails
- Flat plates
- Brick

Steel corner protectors designed specifically for use with chain can be used on objects with sharp edges, but can make installation difficult.



Figure 4.9.1.1  
Chain Bending Against a Sharp Corner

#### 4.9.1.2 MINIMUM BEND RADIUS REQUIREMENT

The minimum corner radius required to avoid bent chain is 3/8" (9.5mm). To check a questionable corner radius, place the integrated radius gauge against the corner, as shown.

If the corner radius is smaller than the gauge, the clamp should not be used without corner protection.

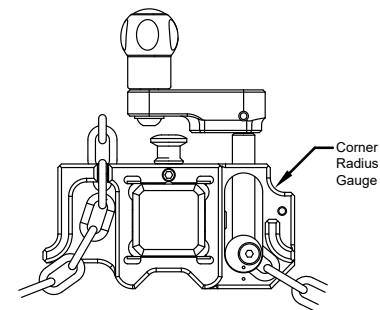

Figure 4.9.1.2A  
Minimum Bend Radius Gauge

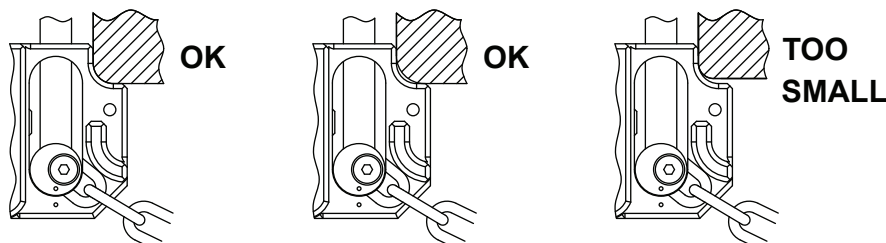

Figure 4.9.1.2B  
Determining Acceptable Radius for Mounting Objects

### 4.9.1.3 CHAIN AND SHACKLE INSPECTION

Chain and/or shackles are considered damaged and should be replaced if any of the following are observed:

- Wear
- Defective or separated welds
- Nicks, cracks, breaks, gouges, stretch, bends
- Discoloration due to excessive heat
- Excessive pitting or corrosion
- Stripped or damaged threads
- Other conditions that doubt as to continued safe use

If the chain is damaged, the clamp should be removed from service and the chain replaced.

Use only TFT supplied or equivalent ASTM A413 certified 3/16" (5.5mm) grade 30 proof coil chain.

### 4.9.1.4 ADDING CHAIN FOR LARGER OBJECTS

Chain can be added by attaching ASTM A413 certified 3/16" (5.5mm) zinc plated steel grade 30 proof coil chain to the extender shackle.

Chain can be obtained from TFT. Chain should be inspected prior to use.

### 4.9.1.5 CHAIN POSITIONING

**WARNING** Reaction forces generated by master stream flows are capable of causing injury and property damage if not properly supported. Install the upper and lower chains as far apart as possible on the mounting object. Always position the monitor between the chains to minimize the stress on the Flex Clamp.

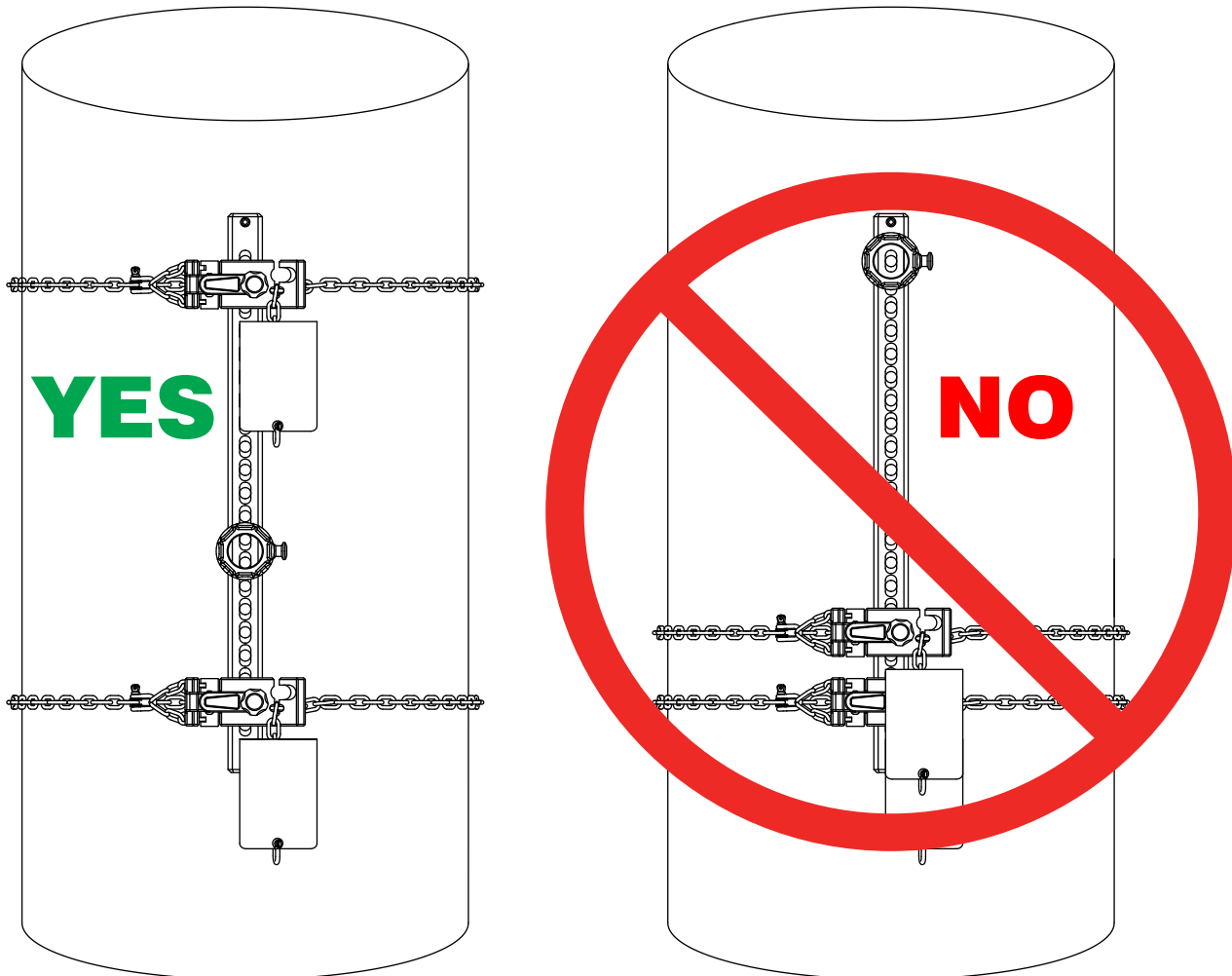
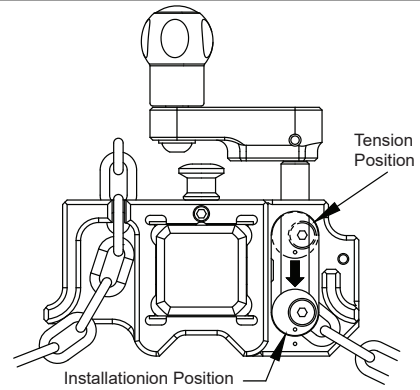

Figure 4.9.1.5  
Positioning the Chain on the Mounting Object

## 4.9.2 INSTALLING THE FLEX CLAMP

- 1) Verify that the chain tensioners on each chain block are in the installation position by rotating the crank counterclockwise until the tensioner stops at the bottom.



- 2) Separate the chain blocks and cross-pin mount from the backbone.

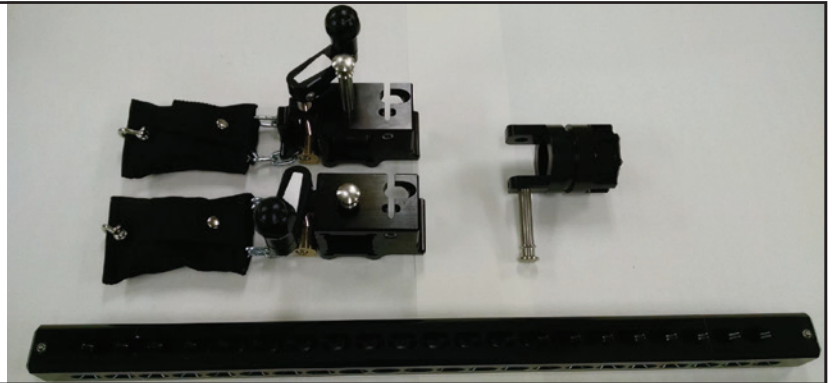

- 3) Release the chain from each bag by unlatching the bag strap. Inspect the chain to verify that it is not twisted, knotted, kinked, or damaged.

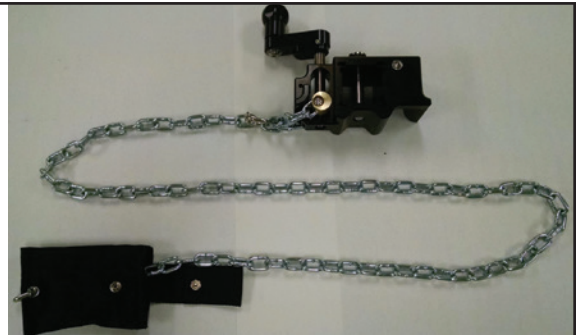

- 4) Wrap the chain around the mounting object and slide it into the take-up slot on the chain block. Pull the chain tight.
- 5) Slide a chain link into the catch. A magnet will help hold the chain in the catch. Verify that the chain is tight and secure in the catch.

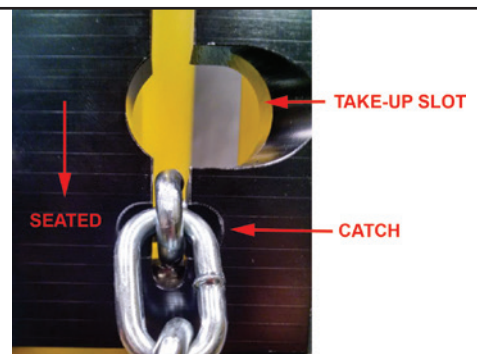
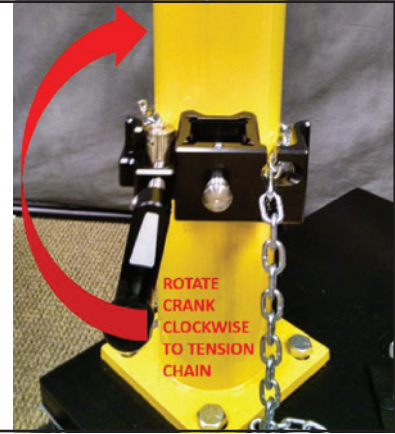

Figure 4.9.2A  
Installing the Flex Clamp

- 6) With the pull pin engaged, rotate the crank clockwise to tension the chain. Double check that the chain is laid straight and secure.



- 7) Disengage the pull pin. Slide the backbone into the chain block and re-engage the pull pin through a hole in the backbone at the desired location.

- 8) Slide the second chain block over the backbone and engage the pull pin in the desired backbone hole. Repeat steps 4 through 6 to install the chain.

- 9) Install the cross-pin mount in the backbone. Secure with a cross-pin. Allow clearance for the monitor.

- 10) Verify that all cross-pins are fully engaged, chains are tight by attempting to shake the clamp. If the clamp moves in relation to the mounting object, tighten the cranks or chain to secure.



Install Backbone in 1st Chain Block



Install 2nd Chain Block on Backbone



Install Cross-Pin Mount on Backbone

Figure 4.9.2B

## 5.0 OPERATING INSTRUCTIONS

### 5.1 INSTALLING THE MONITOR ONTO THE MOUNT

The Hemisphere monitor is designed to be installed by one person by sliding the socket at the base of the monitor onto a mount. The monitor is not attached until the monitor release pin seats in the annular groove on the lower portion of the mount. **Attachment should always be verified by attempting to pull the monitor off the mount.**

It is recommended that the mount be in place and secured before attaching the monitor. The monitor can be installed with or without a hose attached, but it often requires less effort to line up and orient the monitor without an attached hose.

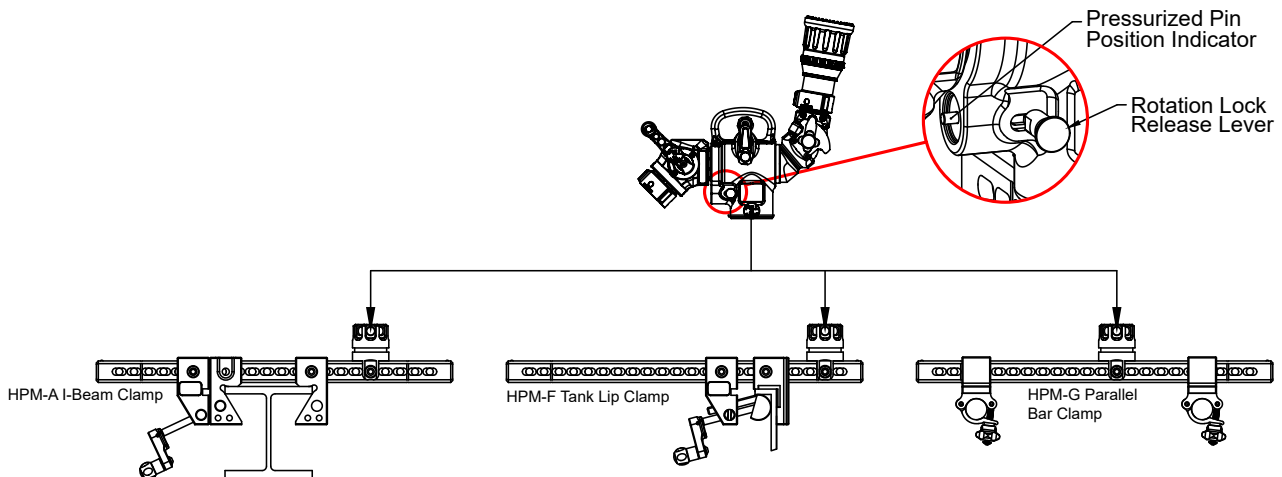

Figure 5.1  
Installing the Monitor

## 5.2 RELEASING THE MONITOR FROM THE MOUNT

The monitor release knob retracts the monitor release pin from the annular groove in the mount. It is recommended that the hose be depressurized and removed before releasing the monitor.

## 5.3 ROTATING THE MONITOR ABOUT THE MOUNT

**⚠️ WARNING** Attempting to rotate the monitor on the mount while flowing can cause the monitor to become out of control, resulting in injury or property damage. Do not force the rotation lock release lever or attempt to rotate the monitor while flowing

Once the monitor is secured to the mount, it may be necessary to re-orient the monitor. Rotation lock release levers on both sides of the monitor provide the ability to rotate the monitor about its mount in 45 degree increments, provided the monitor is not flowing. If the rotation lock release lever is pulled while flowing, a pressurized chamber behind the pin prevents it from unlocking.

Pulling the Rotation Lock Release Levers back (toward the inlet) releases the pin and allows the monitor to rotate on the mount. The levers move to the locked position when released.

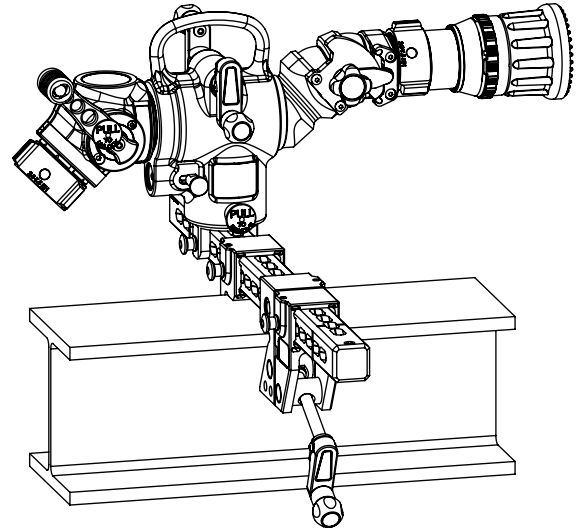

Figure 5.3A  
Rotation Lock Release Levers

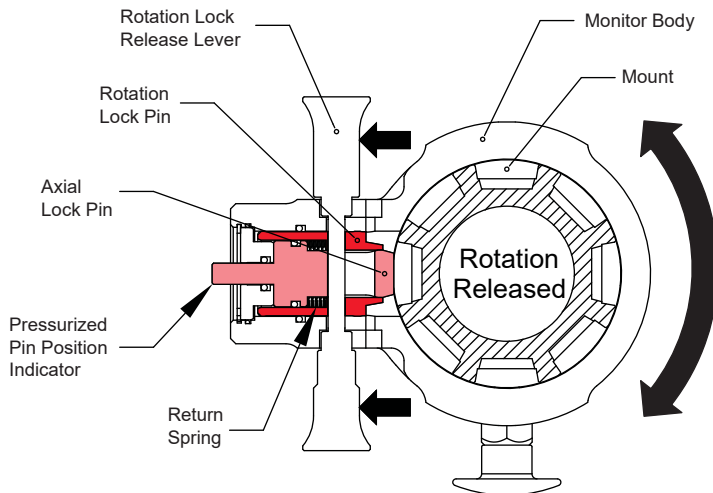

Figure 5.3B  
Rotation Lock in the Released Position

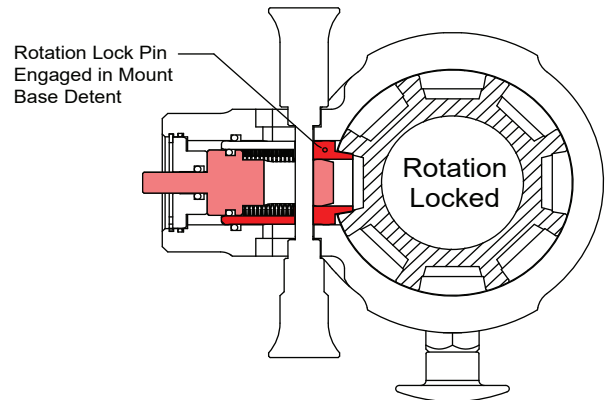

Figure 5.3.C  
Rotation Lock in the Locked Position

## 5.4 ROTATIONAL LOCK SAFELY MECHANISM

The hemisphere has a safety mechanism that incorporates a pressure activated component intended to remind the user not to rotate or release the monitor from its base while flowing by making the lever difficult to pull.

The safety device is pressure activated to push the rotation lock pin (red) into the holes on the base when the monitor is pressurized. Pulling back on the rotation lock release lever with the monitor flowing is dangerous. Although the force required to pull back the rotation lock release lever increases with increased pressure, with enough force, the lever can still be pulled.

Figure 5.4.3 shows the pressurized chamber behind the rotation and axial lock pins when the monitor is flowing. See Section 9.0.2 on page 27 for pressurized lock pin maintenance information.

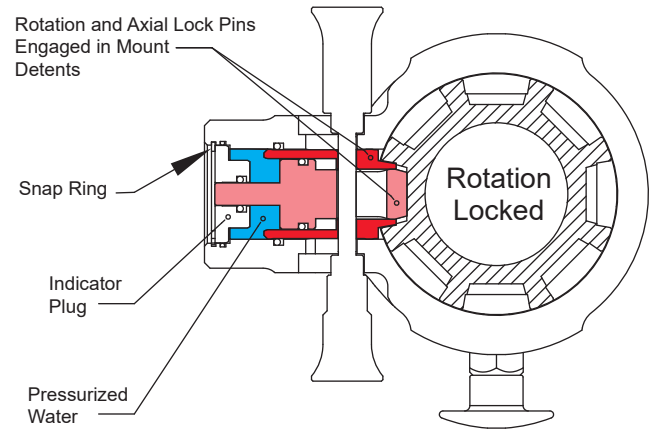
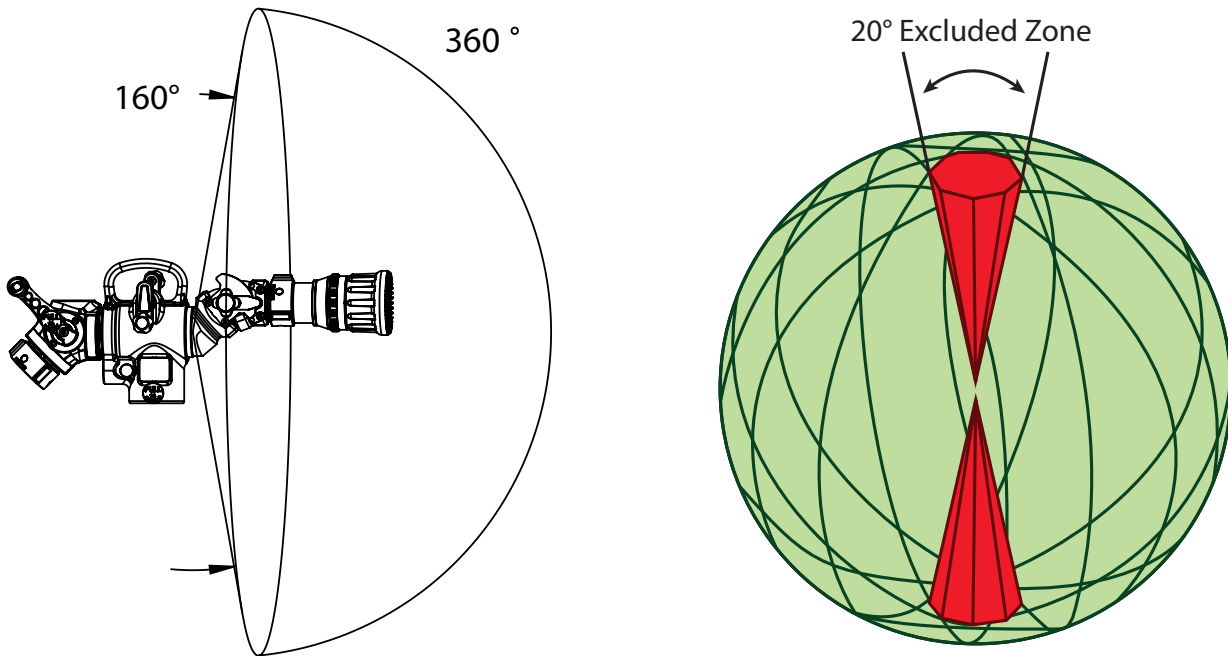

Figure 5.4  
Rotational Lock Safety Mechanism

**WARNING** A damaged or dirty safety mechanism can cause the monitor to become unstable or out of control. To reduce risk of injury or death from an out of control monitor, verify that the safety mechanism operates freely and the indicator pin can be completely depressed.

## 5.5 HEMISPHERE COVERAGE

The figures below show the range of possible directions the Hemisphere nozzle can point overall, through combined rotations about all of its axes. The range shown, almost a complete hemisphere, is achievable without interrupting water flow. When that range is rotated about the monitor mount without water flowing, any point on a sphere, minus the 20 degree regions above and below the monitor, can theoretically be achieved as illustrated. In practice, however, some regions will be obscured by the mount and/or mounted object.



Range of possible nozzle orientations while flowing. Combining main waterway rotation with double ball sweep. Water flow does not need to be interrupted to achieve these rotations.

Range of possible nozzle orientations combining main waterway rotation, with double ball sweep, and 45 degree incremental rotations about the monitor base. Water flow needs to be interrupted to achieve rotation about the monitor mount.

Figure 5.5  
Hemisphere Coverage

### 5.5.1 POINTING THE NOZZLE

Once the mount is secured, the monitor is secured to the mount, and the hose is in place, the initial nozzle flow direction must be established. Without the lock engaged, the double ball pivot is loose and easy to position. Additional resistance can be added by turning the lock knob Figure 5.5.2 until the desired resistance is achieved. To maintain a fixed position, the lock knob can be tightened all the way down.

### 5.5.2 PIVOTING THE OUTLET

The outlet is preceded by a double ball pivot that incorporates a synchronizing mechanism. Each pivot is capable of 40 degrees of rotation, resulting in a total of 80 degrees of sweep Figure 5.5.2. The 80 degree sweep is centered 40 degrees from the rotating monitor body waterway centerline, allowing the outlet to point parallel to the monitor body waterway centerline and up to 80 degrees away from the centerline.

The synchronizing mechanism allows the pivot nearest the outlet to be pointed off of the axis of the pivot nearest the monitor body by taking up the part of the reaction force that would tend to rotate the pivot nearest the monitor body.

See Section 9.0.1 on page 26 for synchronizer maintenance and wear pad repair/ replacement information.

To lock the trajectory in position while flowing, hand tighten the lock knob by turning it clockwise. Do not use a wrench, tool, or cheater bar.

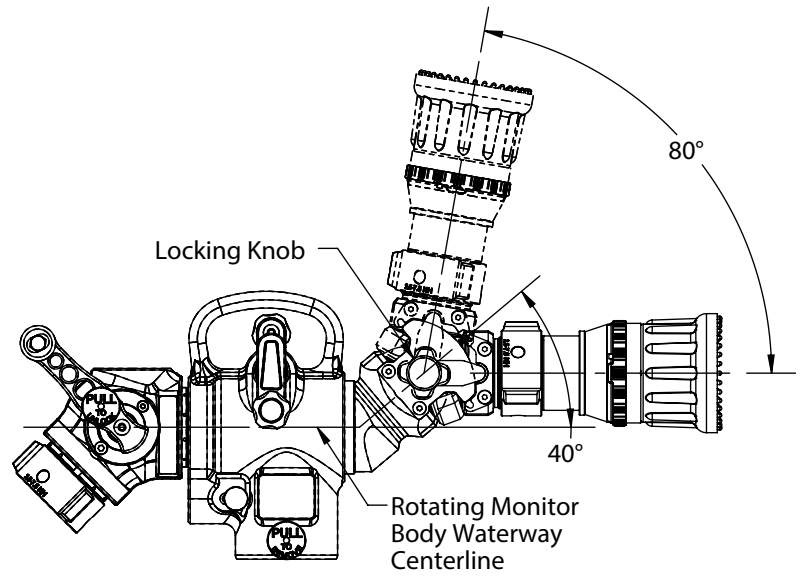

Figure 5.5.2  
Pivoting the Outlet

### 5.5.3 ROTATING THE WATERWAY

The waterway through the monitor body is attached to a double crank shaft by a worm gear and can be rotated a full 360 degrees. The crank arms come in a standard configuration where the holes closest to the knobs attach to the shaft, and the two crank arms are rotated 180 degrees to each other. The force required to rotate the crank can be reduced by removing the screws holding the crank arm, and moving the crank shaft from the bore closest to the knob to the bore furthest from the knob. Either of the crank arms can also be rotated 180 degrees to make both cranks aligned, if preferred.

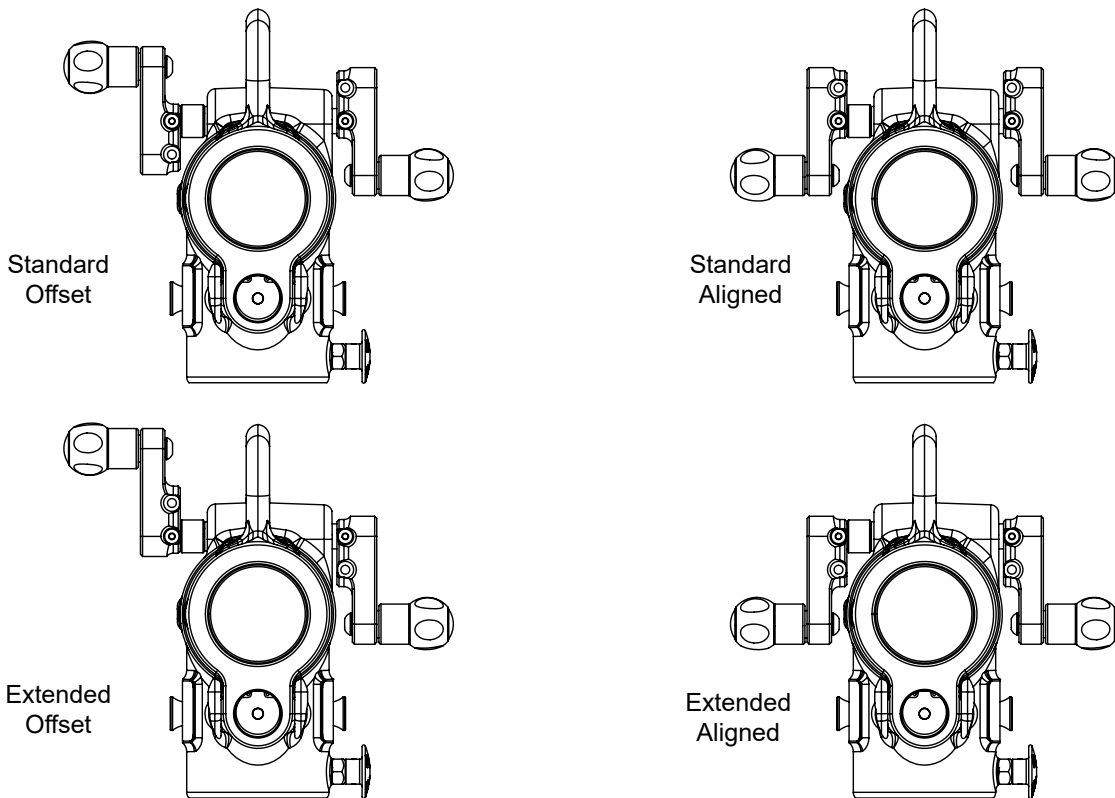

Figure 5.5.3  
Waterway Rotational Crank Arm Position Options

## 5.5.4 QUARTER TURN VALVE



**Sudden changes in valve position can cause pressure spikes (water hammer) and could lead to hose failure or an out of control monitor. Open and close the valve slowly to avoid water hammer.**

The quarter turn valve incorporates a bail style handle to allow opening/closing from either side. The valve locks in the off position to prevent accidental opening. The valve also includes an internal mechanism that prevents the force of the water from influencing the valve position. See LIA-355 2.5" Quarter Turn Hydrant Valve Manual for more information.

## 6.0 FLOW CHARACTERISTICS

The Hemisphere Transportable Monitor is designed for maximum flows of 500 gpm (2000 l/min) and a maximum pressure at the nozzle, while flowing, of 175 psi (12 bar). Do not exceed these limits.



**An inadequate supply of pressure and/or flow will cause an ineffective stream and can result in injury or death. Choose operating conditions to deliver adequate fire suppression. See flow graphs.**

### 6.1 HEMISPHERE PRESSURE LOSS

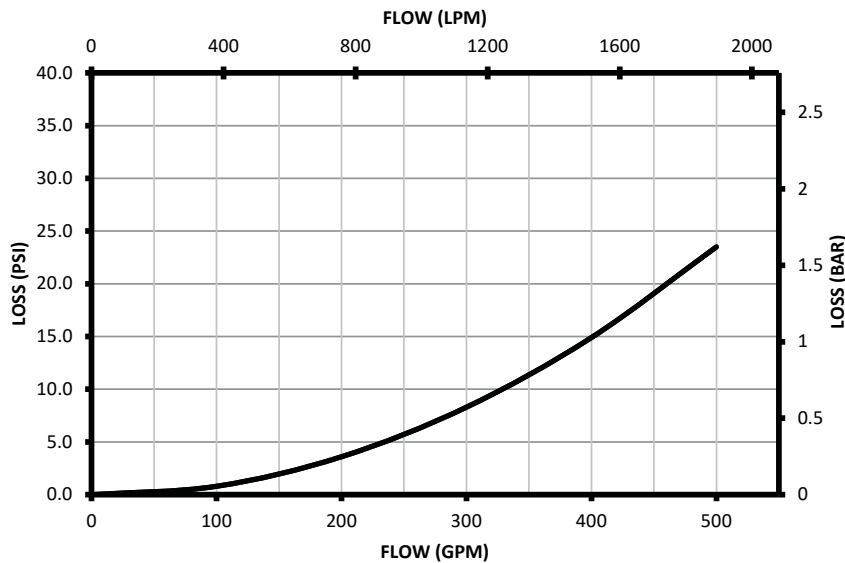

Figure 6.1  
Pressure Loss for the Hemisphere Monitor

### 6.2 AUTOMATIC, FIXED, AND SELECTABLE FLOW NOZZLES

A variety of water or foam nozzles may be used with the Hemisphere. Automatic nozzles maintain a constant pressure by adjusting their opening to match the available flow. Consult the nozzle manufacturer for maximum flow and pressure ratings. In all cases do not exceed 500 gpm (2000 l/min) and/or 175 psi (12 bar) nozzle exit pressure.

### 6.3 STACKED TIPS AND SMOOTH BORE NOZZLES

NOZZLE DIAMETER	NOZZLE EXIT PRESSURE									
	50 PSI		80 PSI		100 PSI		150 PSI		175 PSI	
	FLOW (GPM)	REACTION (LBS)	FLOW (GPM)	REACTION (LBS)	FLOW (GPM)	REACTION (LBS)	FLOW (GPM)	REACTION (LBS)	FLOW (GPM)	REACTION (LBS)
1.0 INCH	210	80	266	126	297	157	364	236	390	275
1-1/4 INCH	328	120	415	196	464	245	—	—	—	—
1-1/2 INCH	473	177	—	—	—	—	—	—	—	—

NOZZLE DIAMETER	NOZZLE EXIT PRESSURE									
	4 BAR		6 BAR		8 BAR		10 BAR		12 BAR	
	FLOW (L/min)	REACTION (KG)	FLOW (L/min)	REACTION (KG)	FLOW (L/min)	REACTION (KG)	FLOW (L/min)	REACTION (KG)	FLOW (L/min)	REACTION (KG)
25 MM	830	40	1000	60	1200	80	1300	100	1400	120
32 MM	1300	70	1700	100	1900	130	—	—	—	—
38 MM	1900	90	—	—	—	—	—	—	—	—

**FLOW EXCEEDS RATING OF HEMISPHERE TRANSPORTABLE MONITOR**



## 6.4 STREAM STRAIGHTENERS

Stream quality, especially with smooth bore nozzles, is improved with the use of a stream straightener. A stream straightener is integrated into the exit of the monitor.

## 7.0 USE WITH FOAM

The nozzle may be used with foam solutions. Refer to fire service training for the proper use of foam.



**For Class B fires, lack of foam or interruption in the foam stream can cause a break in the foam blanket and greatly increase the risk of injury or death. Follow procedures established by the AHJ for the specific fuel and conditions.**



**Improper use of foam or using the wrong type of foam can result in illness, injury, or damage to the environment. Follow foam manufacturer's instructions and fire service training as directed by the AHJ.**

## 8.0 WARRANTY

Task Force Tips LLC, 3701 Innovation Way, Valparaiso, Indiana 46383-9327 USA ("TFT") warrants to the original purchaser of its Hemisphere Monitor ("equipment"), and to anyone to whom it is transferred, that the equipment shall be free from defects in material and workmanship during the five (5) year period from the date of purchase.

TFT's obligation under this warranty is specifically limited to replacing or repairing the equipment (or its parts) which are shown by TFT's examination to be in a defective condition attributable to TFT. To qualify for this limited warranty, the claimant must return the equipment to TFT, at 3701 Innovation Way, Valparaiso, Indiana 46383-9327 USA, within a reasonable time after discovery of the defect. TFT will examine the equipment. If TFT determines that there is a defect attributable to it, it will correct the problem within a reasonable time. If the equipment is covered by this limited warranty, TFT will assume the expenses of repair.

If any defect attributable to TFT under this limited warranty cannot be reasonably cured by repair or replacement, TFT may elect to refund the purchase price of the equipment, less reasonable depreciation, in complete discharge of its obligations under this limited warranty. If TFT makes this election, claimant shall return the equipment to TFT free and clear of any liens and encumbrances.

This is a limited warranty. The original purchaser of the equipment, any person to whom it is transferred, and any person who is an intended or unintended beneficiary of the equipment, shall not be entitled to recover from TFT any consequential or incidental damages for injury to person and/or property resulting from any defective equipment manufactured or assembled by TFT. It is agreed and understood that the price stated for the equipment is in part consideration for limiting TFT's liability. Some states do not allow the exclusion or limitation of incidental or consequential damages, so the above may not apply to you.

TFT shall have no obligation under this limited warranty if the equipment is, or has been, misused or neglected (including failure to provide reasonable maintenance) or if there have been accidents to the equipment or if it has been repaired or altered by someone else.

**THIS IS A LIMITED EXPRESS WARRANTY ONLY. TFT EXPRESSLY DISCLAIMS WITH RESPECT TO THE EQUIPMENT ALL IMPLIED WARRANTIES OF MERCHANTABILITY AND ALL IMPLIED WARRANTIES OF FITNESS FOR A PARTICULAR PURPOSE. THERE IS NO WARRANTY OF ANY NATURE MADE BY TFT BEYOND THAT STATED IN THE DOCUMENT.**

This limited warranty gives you specific legal rights, and you may also have other rights which vary from state to state.

## 9.0 MAINTENANCE

TFT products are designed and manufactured to be damage resistant and require minimal maintenance. However, as the primary firefighting tool upon which your life depends, it should be treated accordingly. The unit should be kept clean and free of dirt by rinsing with water after each use. Any inoperable or damaged parts should be repaired or replaced before placing the unit in service. To help prevent mechanical damage, do not drop or throw equipment.

In applications where appliances are left continuously connected to the apparatus or other devices or are used where water is trapped inside the appliance, the appliance must be flushed with fresh water following each use and inspected for damage.

This appliance should be disconnected, cleaned and visually inspected inside and out at least quarterly, or as water quality and use may require. Moving parts such as handles, valve ball and couplings should be checked for smooth and free operation. Seals shall be greased as needed with Silicone based grease such as Molykote 112. Any scrapes that expose bare aluminum should be cleaned and touched up with enamel paint such as Rust-Oleum. Replace any missing or damaged parts before returning to service.

Any equipment taken out of service due to failure should be returned to the factory for repair or replacement. If you have any questions regarding the testing or maintenance of your valve, please call Task Force Tips at 800-348-2686.

### 9.0.1 DOUBLE BALL PIVOT SYNCHRONIZER AND LOCK MAINTENANCE

It is important to clean, inspect, and maintain the synchronizing mechanism regularly, and before each use, as needed. The assembly can be brushed clean with soap and water. The mechanism consists of a cam, cam follower, wear pads, and a lock mechanism.

The wear pads are press fit in place, and will need to be maintained periodically.

Indications that maintenance is needed include:

- Difficulty rotating the double ball swivel assembly
- Inability to lock the double balls
- Metal to metal contact between the cam follower and the cam

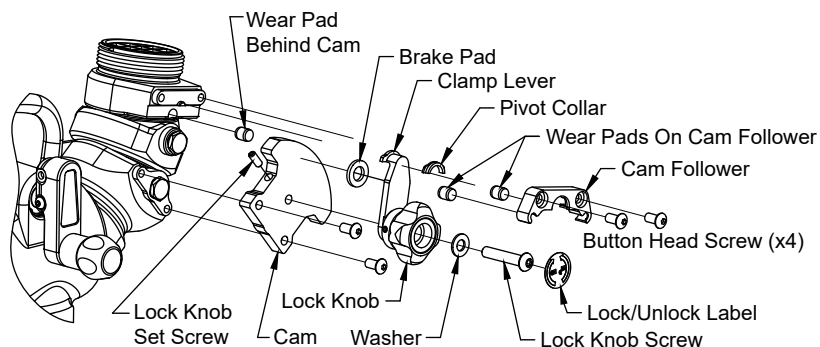

To replace the two pads on the cam follower:

1. Remove the (4) 5/16" button head screws (with a 3/16" hex wrench) that hold the cam follower and cam in place.
2. Remove the cam follower and cam.
3. Secure the cam follower in a soft jaw (or equivalent) vise, and tap with a punch and hammer on the backside of the pads until they are removed.
4. Replace the pad by tapping a new pad into the bore with a punch and hammer.

To replace the pad located behind the cam in the pocket on the side of the pivot ball:

1. Drill the center of the worn pad with a 1/8" drill, to form a pilot hole, then drill with a 3/8" drill bit. Both drills must be fitted with a travel stop to prevent the drill from going more than 7/16" into the pad.
2. The remaining pad material can be pried out with a screwdriver or a small pry bar.
3. Replace the pad by tapping a new pad into the bore with a punch and hammer.

Apply Loctite #242 (blue) to all screws before reassembly.

The brake pad and pivot collar should be inspected periodically to ensure that the lock provides sufficient engagement to prevent unwanted nozzle sweep.

To replace the brake pad:

1. Remove the cam follower
2. Remove the pivot collar from the clamp lever
3. Remove the set screw in the side of the cam. Unscrew the lock knob from the cam.
4. Pry the brake pad off of the boss it is press fit onto.
5. Replace the pad by tapping a new pad into the boss with a hammer.

#### Reassembly:

1. Apply Loctite #242 (blue) to all screws before reassembly, except the lock knob screw.
  - A. For the lock knob screw, apply Loctite to the female threads on the cam that mate with the lock knob screw. The lock knob screw should be greased with Chuck-eez (or equivalent molybdenum disulfide based grease) on the upper half of the threads only. Any grease on the lower 1/2" of threads should be cleaned with acetone before assembling the screw onto the cam.
2. Replace the pivot collar, clamp lever and cam follower.
3. Once all parts of the lock mechanism, except for the lock/unlock label, are assembled, and before the Loctite sets, rotate the lock knob counterclockwise about the lock knob screw until the head of the screw is snug against the washer and the washer is snug against the lock knob.
4. Rotate the knob/screw clockwise until the knob snugs up against the clamp lever. Turn it back 1/4 turn counterclockwise and tighten the set screw.
5. Verify that the double ball assembly moves freely with the lock knob in the unlock position, and that the ball swivels cannot be moved with the lock/unlock knob in the lock position.
6. Clean any grease off the label groove with acetone and apply a new lock/unlock label.

### 9.0.2 LOCK PIN ASSEMBLY MAINTENANCE

Free movement of the rotational lock pin can be verified by pulling back on the rotation lock pin release lever. Movement of the axial lock pin can be verified by pressing in on the indicator. The lock pin assembly should be disassembled, inspected, and cleaned if the pins are not functioning properly.

1. Use snap ring pliers to remove the snap ring retaining the indicator plug.
2. Use two 9/16" open end wrenches to remove one of the rotation lock release levers from the rotation release lever shaft.
3. Replace damaged or worn pins or O-rings.
  - A. Apply a silicone-based grease such as Molykote 112 to all seals prior to installation.
  - B. Apply a light coat of Chuck-eez (or equivalent molybdenum disulfide based grease) to the pin bores in the monitor body and the rotational lock pin prior to installing the pins.
4. Apply Loctite #246 (red) compound to the pin retract shaft threads before reinstalling the rotation lock release lever.

### 9.1 SERVICE TESTING

In accordance with NFPA 1962, equipment must be tested a minimum of annually. Units failing any part of this test must be removed from service, repaired and retested upon completion of the repair.

### 9.2 REPAIR

Factory service is available with repair time seldom exceeding one day in our facility. Factory serviced equipment is repaired by experienced technicians, wet tested to original specifications, and promptly returned. Repair charges for non-warranty items are minimal. Any returns should include a note as to the nature of the problem and whom to reach in case of questions.

Repair parts and service procedures are available for those wishing to perform their own repairs. Task Force Tips assumes no liability for damage to equipment or injury to personnel that is a result of user service. Contact the factory or visit the web site at [tft.com](http://tft.com) for parts lists, exploded views, test procedures and troubleshooting guides.

Performance tests shall be conducted on the equipment after a repair, or anytime a problem is reported to verify operation in accordance with TFT test procedures. Consult factory for the procedure that corresponds to the model and serial number of the equipment. Any equipment which fails the related test criteria should be removed from service immediately. Troubleshooting guides are available with each test procedure or equipment can be returned to the factory for service and testing.

 **Any alterations to the product or its markings could diminish safety and constitutes a misuse of this product.**

 **All replacement parts must be obtained from the manufacturer to assure proper operation of the device.**

### 10.0 EXPLODED VIEWS AND PARTS LISTS

Exploded views and parts lists are available at [tft.com/serial-number](http://tft.com/serial-number).

## 11.0 OPERATION AND INSPECTION CHECKLIST

**BEFORE EACH USE**, appliances must be inspected to this checklist:

1. All valves (if so equipped) open and close fully and smoothly
2. Waterway is clear of obstructions
3. There is no damage to any thread or other connection
4. All locks and hold-down devices work properly
5. The pressure setting on the relief valve (if so equipped) is set correctly
6. Gaskets are in good repair
7. There is no obvious damage such as missing, broken or loose parts
8. There is no damage to the appliance that could impair safe operation (e.g. dents, cracks, corrosion, or other defects)
9. All swiveling elements rotate freely
10. Nozzle is securely attached

**BEFORE BEING PLACED BACK IN SERVICE**, appliances must be inspected to this list:

1. All valves (if so equipped) open and close smoothly and fully
2. The waterway is clear of obstructions
3. There is no damage to any thread or other type connection
4. The pressure setting of the relief valve, if any, is set correctly
5. All locks and hold-down devices work properly
6. Internal gaskets are in accordance with NFPA 1962
7. There is no damage to the appliance that could impair safe operation (e.g. dents, cracks, corrosion, or other defects)
8. All swiveling connections rotate freely
9. There are no missing parts or components
10. The marking for maximum operating pressure is visible
11. There are no missing, broken, or worn lugs on couplings

*NFPA 1962: Standard for the care, use, inspection, service testing, and replacement of fire hose, couplings, nozzles and fire hose appliances. (2013 ed., Section 6.2.1). Quincy, MA: National Fire Protection Agency.*



**Equipment failing any part of the checklist is unsafe for use and must have the problem corrected before use or being placed back into service. Operating equipment that has failed the checklist is a misuse of this equipment.**