

Flanged Monitor and Flanged Oscillating Monitor

INSTRUCTION FOR INSTALLATION, OPERATION, AND MAINTENANCE

⚠ DANGER

Understand manual before use. Operation of this device without understanding the manual and receiving proper training is a misuse of this equipment. Obtain safety information at tft.com/serial-number.

This equipment is intended for use by trained and qualified emergency services personnel for firefighting. All personnel using this equipment shall have completed a course of education approved by the Authority Having Jurisdiction (AHJ).

This instruction manual is intended to familiarize firefighters and maintenance personnel with the operation, servicing, and safety procedures associated with this product. This manual should be kept available to all operating and maintenance personnel.

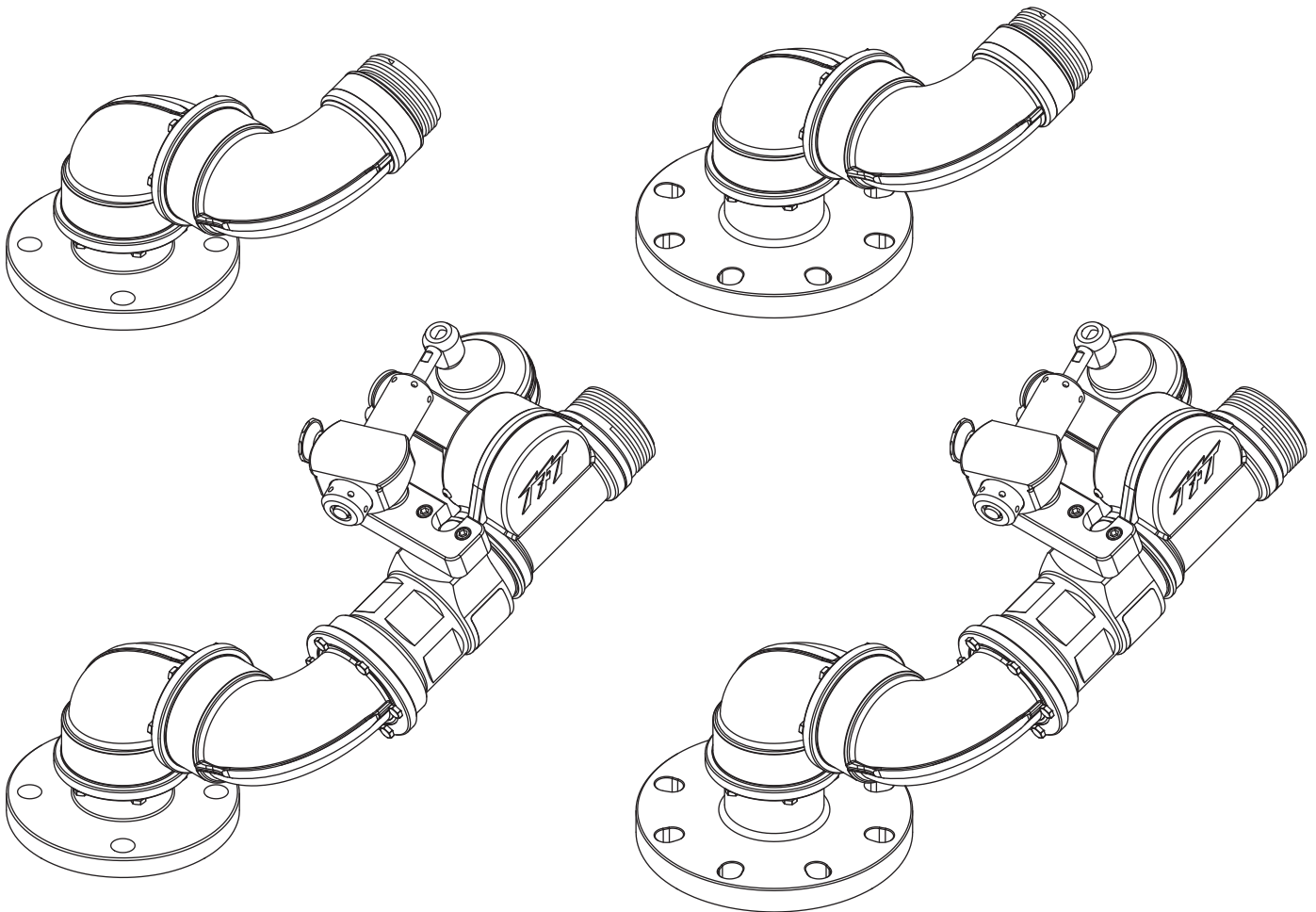

[\(see section 3.2\)](#) for Flow/Pressure Operations Envelope

TABLE OF CONTENTS

- 1.0 MEANING OF SAFETY SIGNAL WORDS
- 2.0 SAFETY
- 3.0 GENERAL INFORMATION
 - 3.1 MECHANICAL SPECIFICATIONS
 - 3.2 OPERATING ENVELOPE
 - 3.3 USE WITH SALT WATER
 - 3.4 INLETS AND OUTLETS
 - 3.5 OVERALL DIMENSIONS
- 4.0 INSTALLATION
 - 4.1 STRUCTURAL REQUIREMENTS
 - 4.2 TRAVEL RANGE LIMITS
 - 4.3 INSTALLING THE MONITOR
 - 4.4 LOCKING THE MONITOR
 - 4.5 NOZZLE INSTALLATION
 - 4.6 DRAINING RESIDUAL WATER
- 5.0 OPERATION OF OSCILLATING MONITORS
 - 5.1 TO ENGAGE THE OSCILLATING MECHANISM
 - 5.2 TO DISENGAGE THE OSCILLATING MECHANISM
 - 5.3 COVERAGE AREA OF THE OSCILLATING MONITOR
- 6.0 FLOW CHARACTERISTICS
 - 6.1 FRICTION LOSS
- 7.0 WARRANTY
- 8.0 MAINTENANCE
 - 8.1 SERVICE TESTING
 - 8.2 REPAIR
- 9.0 EXPLODED VIEWS AND PARTS LISTS
- 10.0 OPERATION AND INSPECTION CHECKLIST

DANGER
PERSONAL RESPONSIBILITY CODE

The member companies of FEMSA that provide emergency response equipment and services want responders to know and understand the following:

1. Firefighting and Emergency Response are inherently dangerous activities requiring proper training in their hazards and the use of extreme caution at all times.
2. **IT IS YOUR RESPONSIBILITY** to read and understand any user's instructions, including purpose and limitations, provided with any piece of equipment you may be called on to use.
3. **IT IS YOUR RESPONSIBILITY** to know that you have been properly trained in Firefighting and/or Emergency Response and in the use, precautions, and care of any equipment you may be called upon to use.
4. **IT IS YOUR RESPONSIBILITY** to be in proper physical condition and to maintain the personal skill level required to operate any equipment you may be called upon to use.
5. **IT IS YOUR RESPONSIBILITY** to know that your equipment is in operable condition and has been maintained in accordance with the manufacturer's instructions.
6. Failure to follow these guidelines may result in death, burns or other severe injury.

Fire and Emergency Manufacturers and Service Association, Inc.
PO Box 147, Lynnfield, MA 01940 • www.FEMSA.org

© 2020 FEMSA. All Rights Reserved.

FEMSA

1.0 MEANING OF SAFETY SIGNAL WORDS

A safety related message is identified by a safety alert symbol and a signal word to indicate the level of risk involved with a particular hazard. Per ANSI Z535.6, the definitions of the four signal words are as follows:



DANGER indicates a hazardous situation which, if not avoided, will result in death or serious injury.



WARNING indicates a hazardous situation which, if not avoided, could result in death or serious injury.



CAUTION indicates a potentially hazardous situation which, if not avoided, could result in minor or moderate injury.



NOTICE is used to address practices not related to physical injury.

2.0 SAFETY



An inadequate supply of pressure and/or flow will cause an ineffective stream and can result in injury or death. Choose operating conditions to deliver adequate fire suppression. See flow graphs.



This equipment is intended for use by trained personnel for firefighting. Use of this equipment for other purposes may involve hazards not addressed by this manual. Seek appropriate guidance and training to reduce risk of injury.



Injury or damage can occur from an inadequately supported monitor. The mounting must be capable of supporting the nozzle reaction force which can be as high as 350 lbs (160 kg).



The stream exiting a nozzle is very powerful and capable of causing injury and property damage. Make sure the nozzle is securely attached and pointing in a safe direction before water is turned on. Do not direct water stream to cause injury or damage to persons or property.



Equipment may be damaged if frozen while containing significant amounts of water. Such damage may be difficult to detect visually. Subsequent pressurization can lead to injury or death. Any time the equipment is subject to possible damage due to freezing, it must be tested and approved for use by qualified personnel before being considered safe for use.

3.0 GENERAL INFORMATION

The Flanged Monitor can be used for exposure protection, cooling, or by adding the oscillating mechanism, any other situation where it is desirable to have a monitor sweep back and forth. It is intended for mounting on fixed piping structures. The Oscillator operates between 20 degrees either side of center, and the monitor is adjustable to 90 degrees up and 45 degrees down relative to the flange. The maximum flow rate is 500 gallons per minute.

3.1 MECHANICAL SPECIFICATIONS

	MANUAL		OSC	
	US	METRIC	US	METRIC
Weight	9.3 lbs	4.2 kg	20.8 lbs	9.4 kg
Maximum Flow	500 gpm	1900 L/min	500 gpm	1900 L/min
Maximum Operating Pressure	175 psi	12 bar	175 psi	12 bar
Operating Temperature Range of Fluid	33°F to 120°F / 1°C to 50°C			
Storage Temperature Range	-40 to 150°F / -40 to 65°C			
Materials	ANSI A356.0-T6 Aluminum, Stainless, Nylon			

Figure 3.1

3.2 OPERATING ENVELOPE



Damage or injury could result from operating the monitor beyond the safe operating envelope. Do not operate the monitor outside the envelope in the following graph(s).

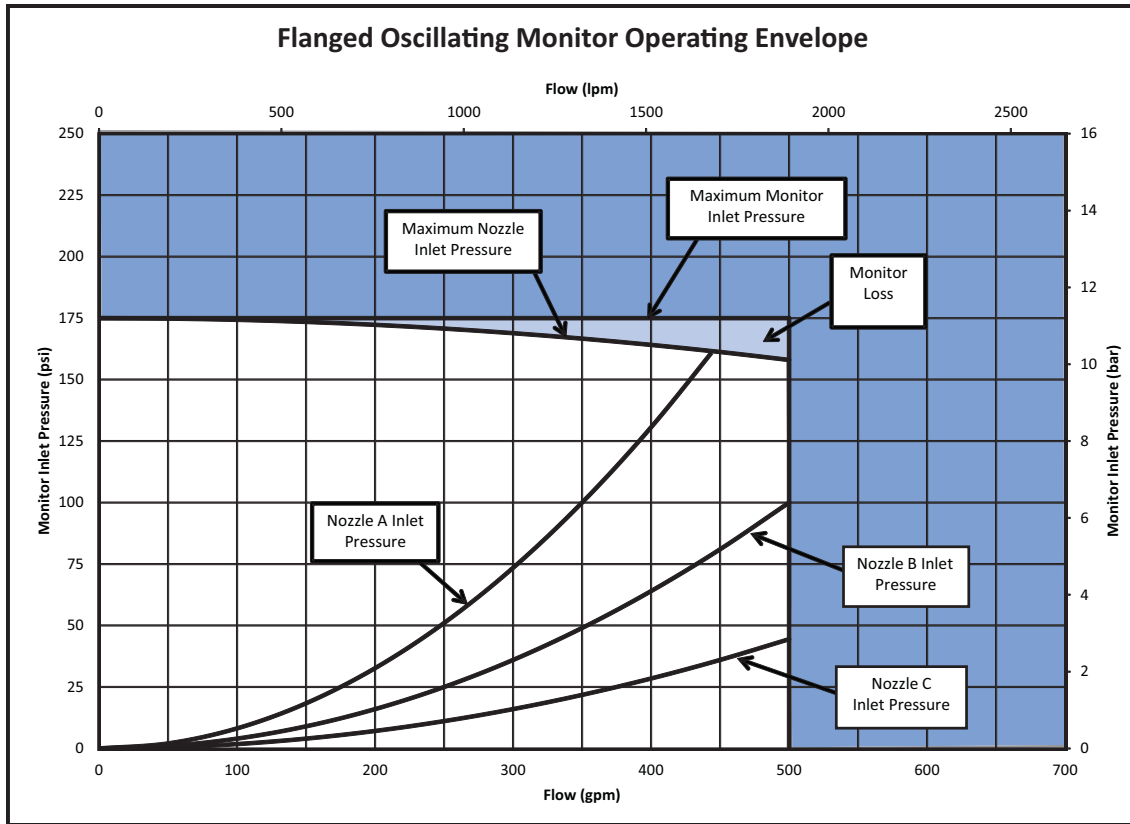

Nozzle A flows 350 gpm (1300 l/min), at 100 psi (7 bar), K factor = 35
 Nozzle B flows 500 gpm (1900 l/min), at 100 PSI (7 bar), K factor = 50
 Nozzle C flows 750 gpm (2900 l/min), at 100 PSI (7 bar), K factor = 75

3.3 USE WITH SALT WATER

Use with salt water is permissible provided the equipment is thoroughly cleaned with fresh water after each use. The service life of the equipment may be shortened due to the effects of corrosion, and is not covered under warranty.

3.4 INLETS AND OUTLETS

The standard Flanged Monitor inlet is a 3" ANSI 150 flange. A monitor inlet flange with oblong bolt holes for 4" ANSI 150/DN100 PN 16 is also available. The standard outlet is a 2.5"-7.5 National Hose male. Other inlet and outlet adapters are available at the time of order.

3.5 OVERALL DIMENSIONS

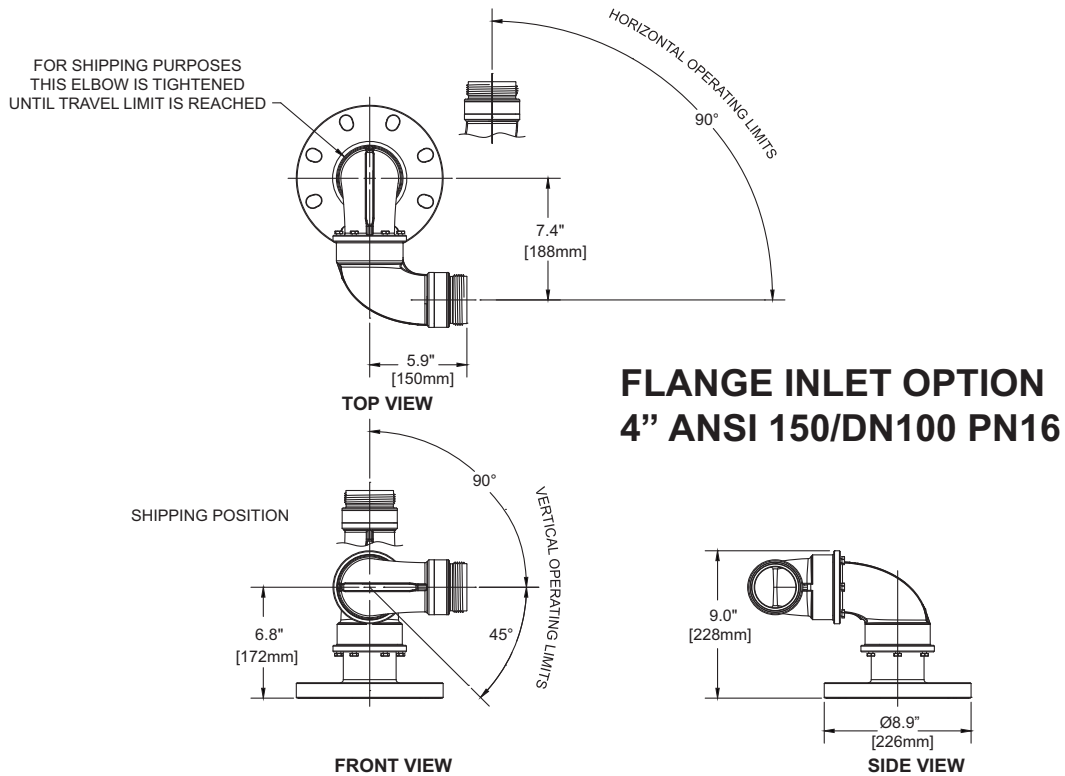

Figure 3.5A

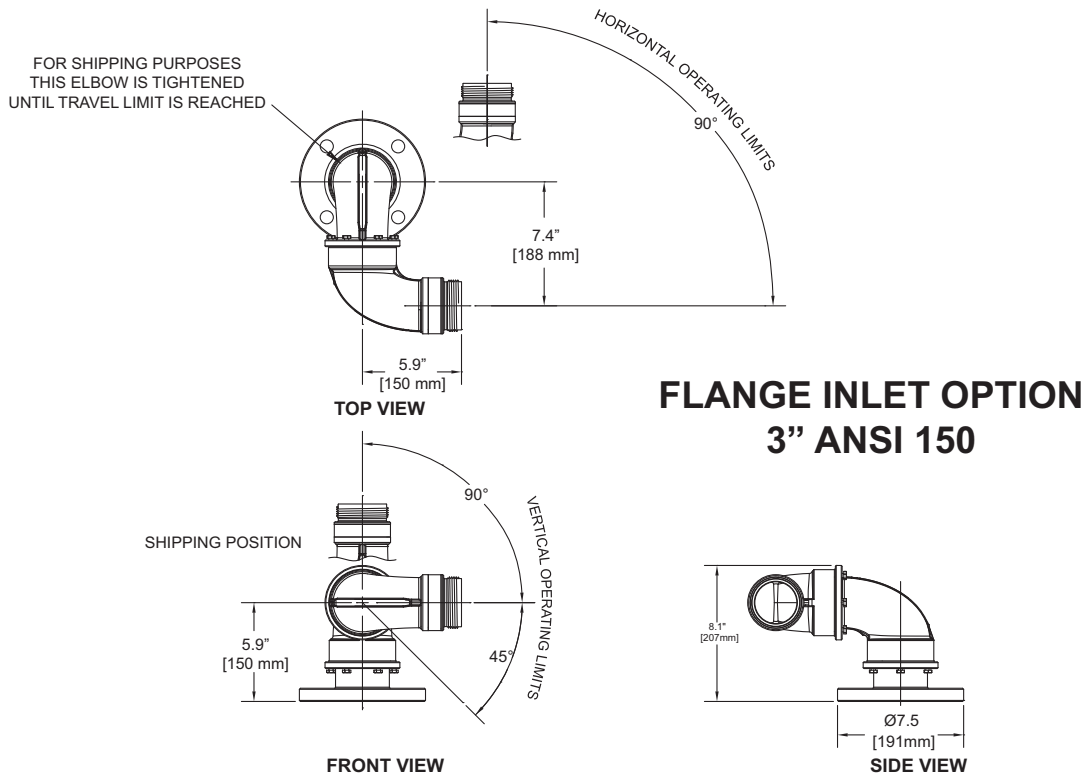
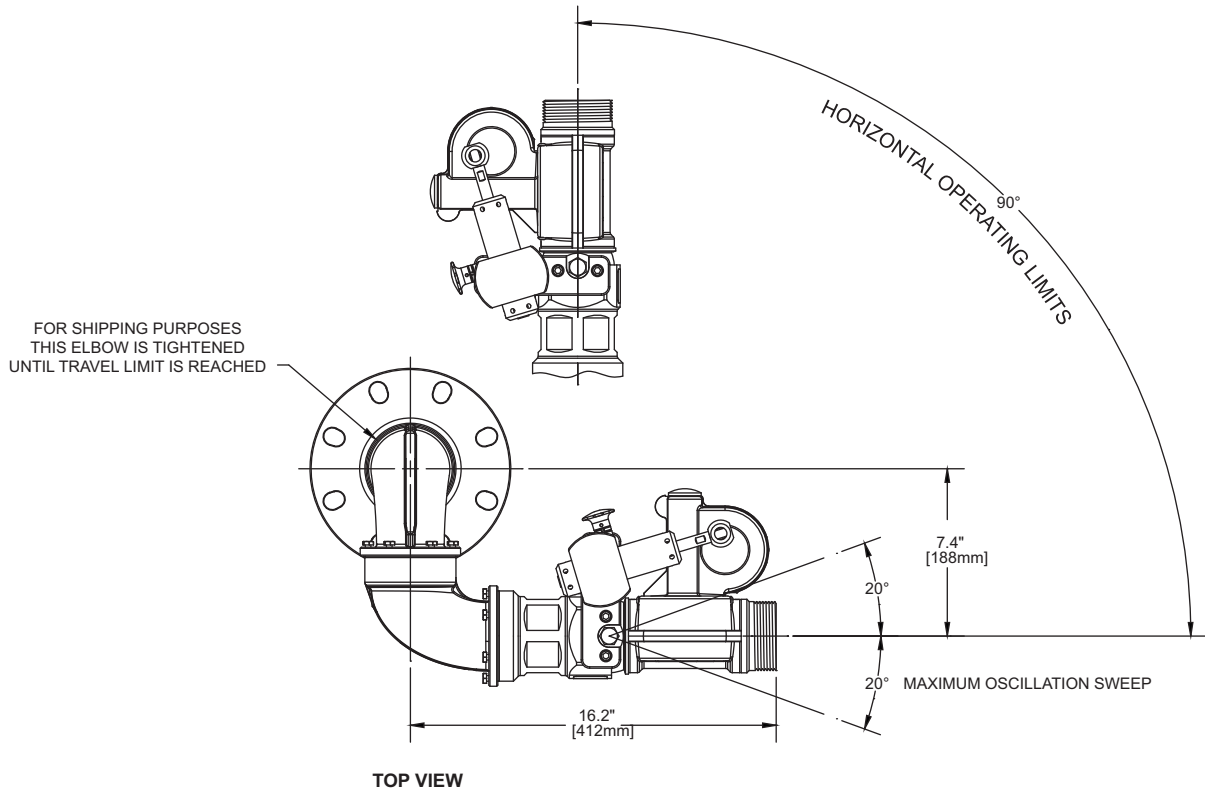

Figure 3.5B



**FLANGE INLET OPTION
4" ANSI 150/DN100 PN16**

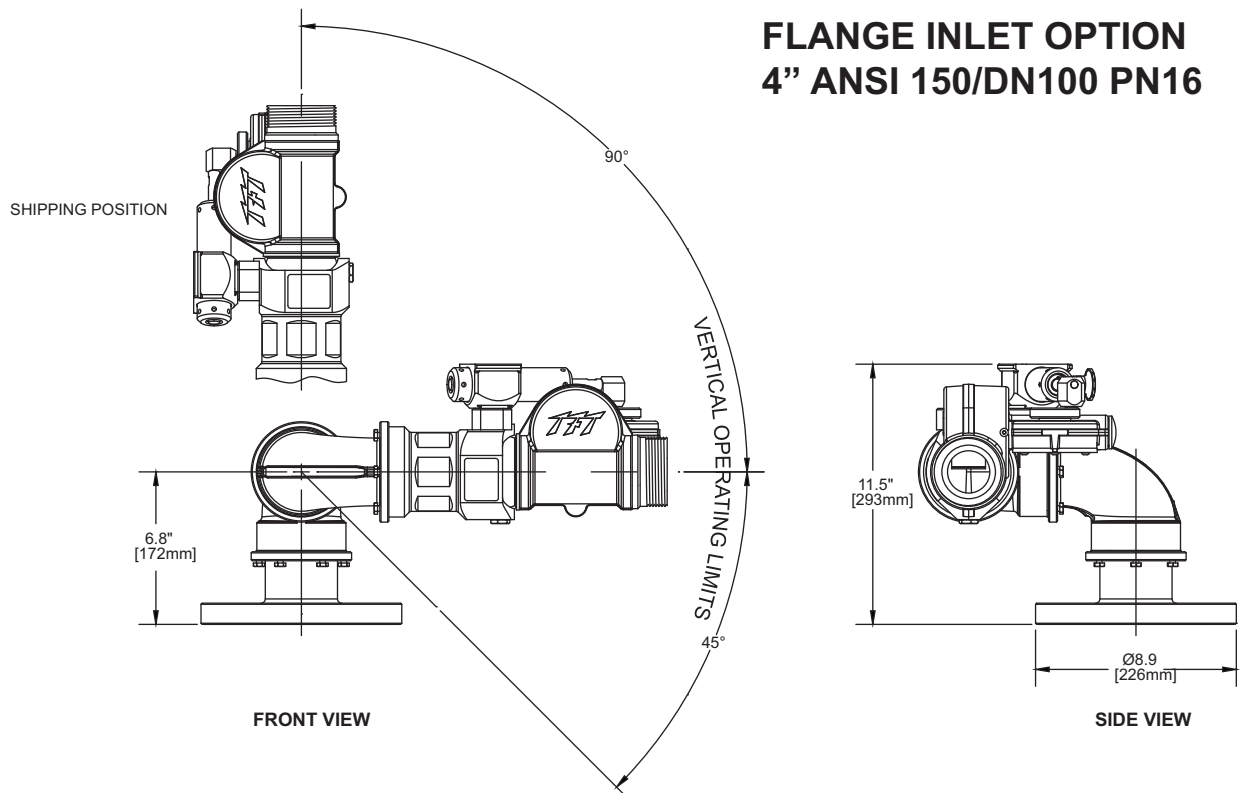
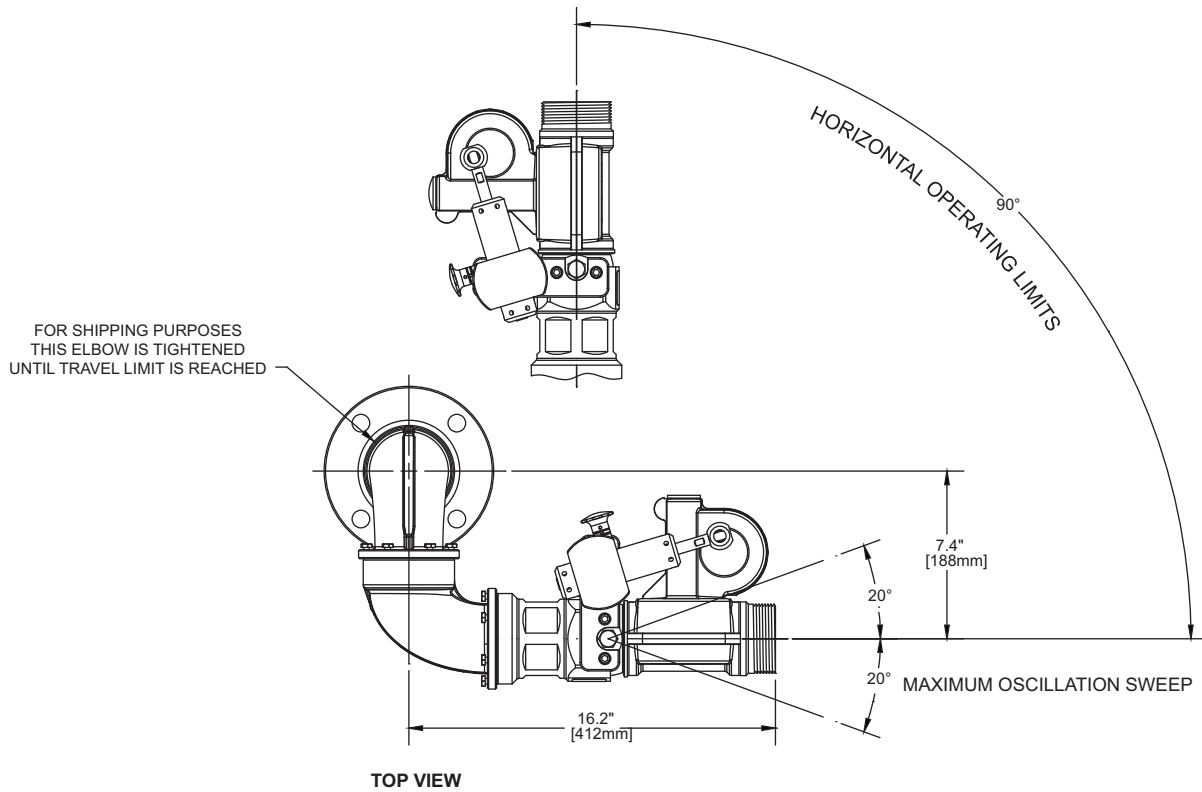

Figure 3.5C



**FLANGE INLET OPTION
3" ANSI 150**

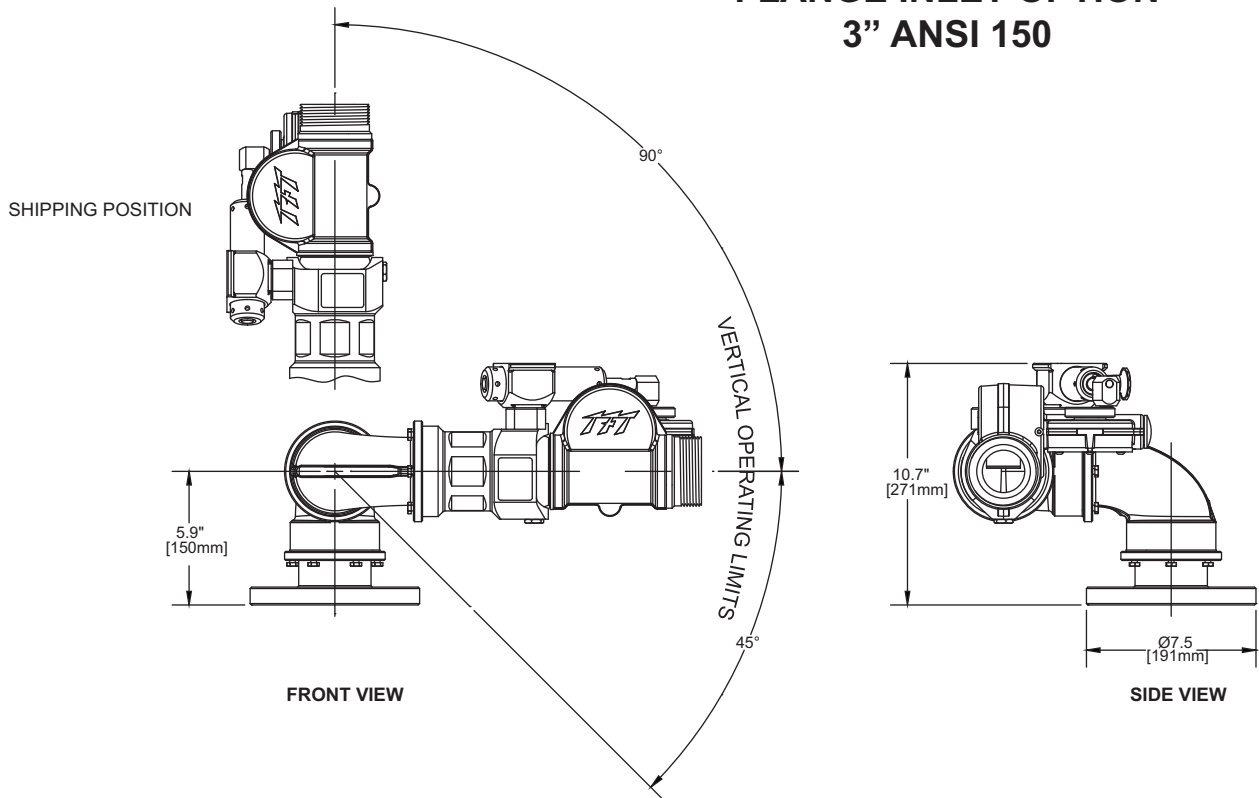

Figure 3.5D

4.0 INSTALLATION

4.1 STRUCTURAL REQUIREMENTS



Reaction forces generated by master stream flows are capable of causing injury and property damage if not properly supported. Monitors should be securely installed by qualified individuals.

- Mounting objects must be capable of withstanding maximum nozzle reaction force.
- The monitor must be securely mounted to rigid support members.
- Do not use flanges or pipe made from plastic for monitor mounting.
- Torque all fasteners to specified values.

The structure that the monitor is mounted to must withstand the internal pressure of the monitor as well as shear and bending forces due to nozzle reaction.

For flanged connections, the use of flat flanges without raised faces is recommended. Use a ring gasket as defined in ASME 16.21 or ISO 7483. Tighten flange bolts in an alternating sequence as shown below. Tighten sequentially each bolt or stud three times to 30%, then 60%, and finally 100% of the specified torque. Tighten to a total of 76-80 ft-lb (100-110 N·m).

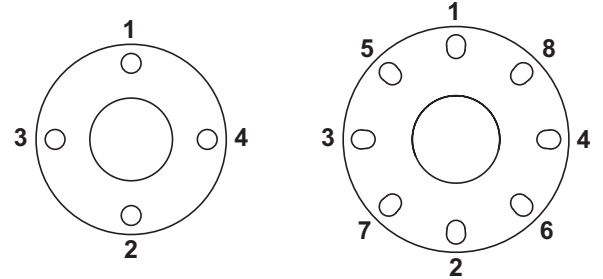

Tighten Sequentially Each Bolt Three Times to a Total of 76-80 ft-lb (100-110 N·m)

Figure 4.1

4.2 TRAVEL RANGE LIMITS

The range of elevation travel for the Flanged Monitor is 90 degrees above and 45 degrees below relative to the flange. The range of horizontal travel for the Flanged Monitor is 90 degrees. The maximum sweep angle for the Flanged Oscillating Monitor is 20 degrees of center.

Flanged OSC Monitor Travel

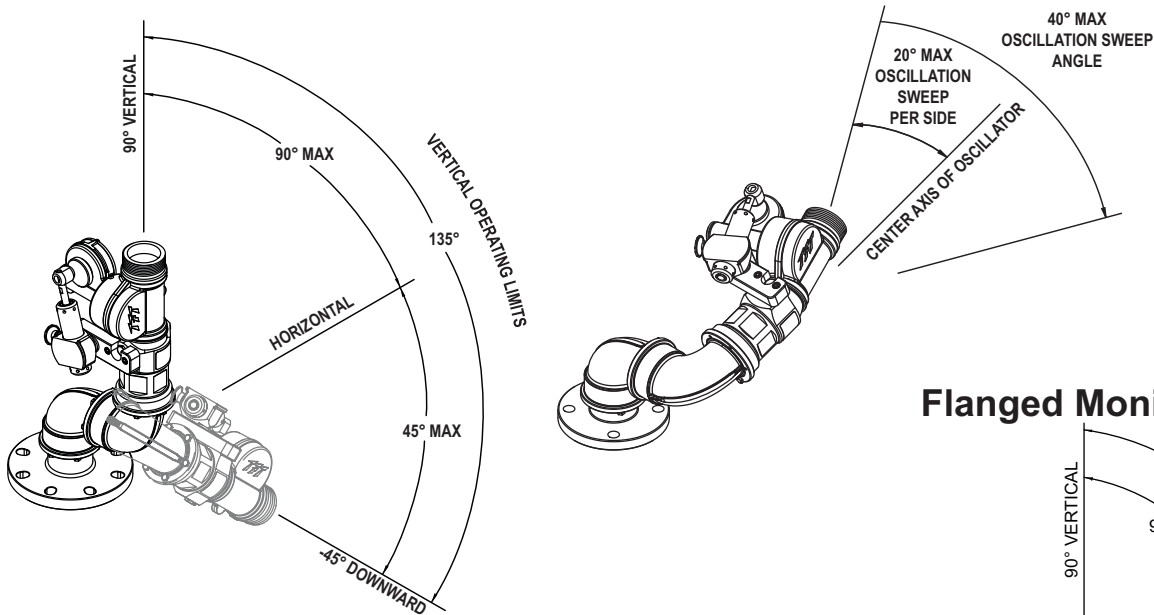

Flanged Monitor Travel

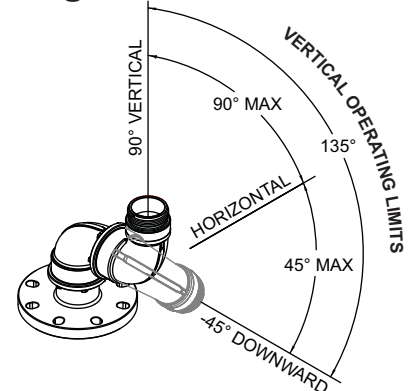

Adjusting the monitor swivels beyond their intended range of travel can disable the locking screws, causing a sudden change in monitor direction and resulting in injury from an out of control stream. The monitor is shipped from the factory at the highest travel limit. Do not loosen the monitor swivels to operate beyond the travel limits.

4.3 INSTALLING THE MONITOR

To install the monitor:

STEP 1

Point the monitor at the desired target.

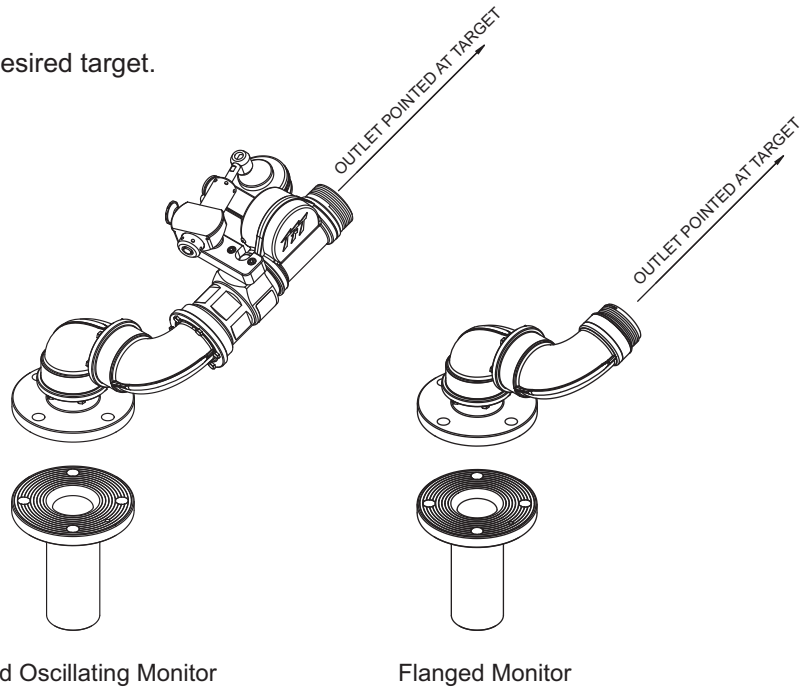

Figure 4.3A

STEP 2

Rotate the monitor flange until bolt holes are aligned with the mating flange.
Hand-tighten all flange bolts.

IMPORTANT:
MONITOR FLANGE
MAY BE ROTATED
≤ 90° WHEN ALIGNING
BOLT HOLES

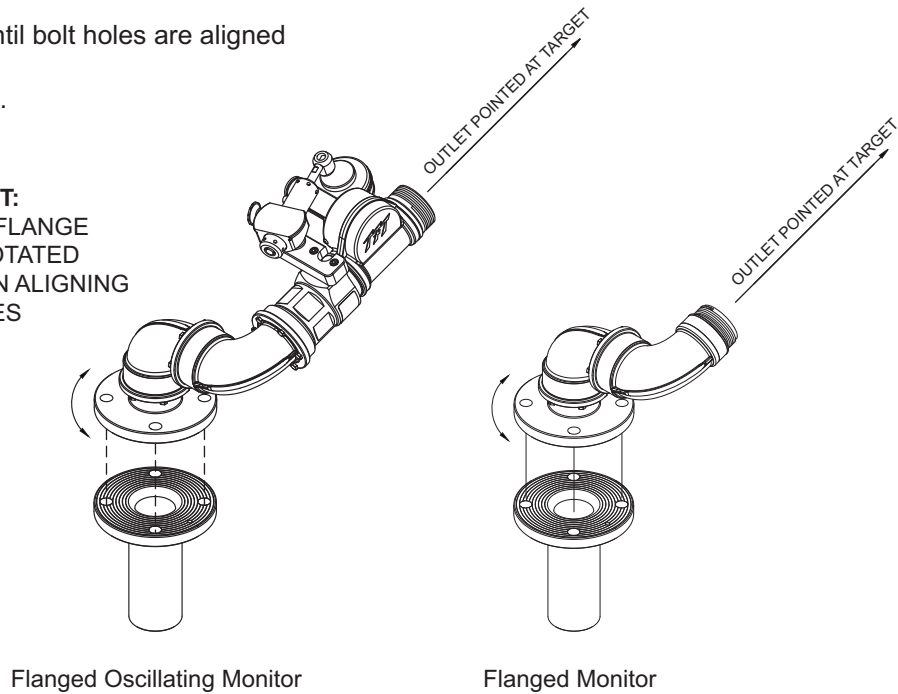

Figure 4.3B

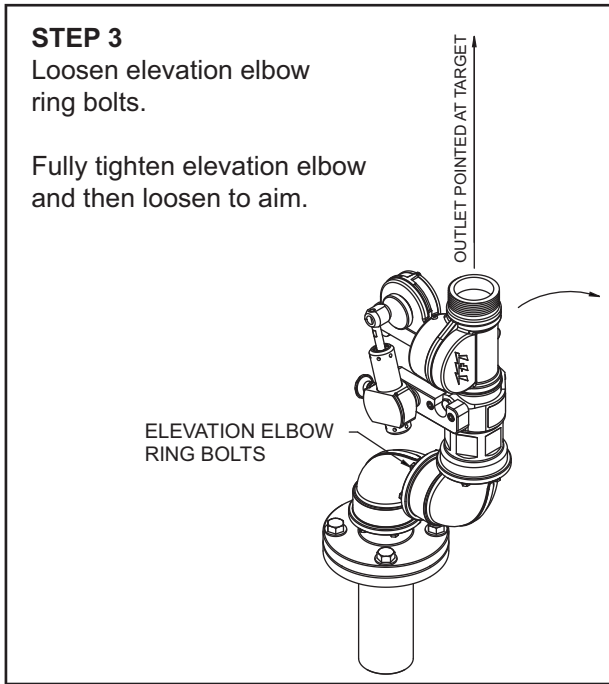

Figure 4.3C

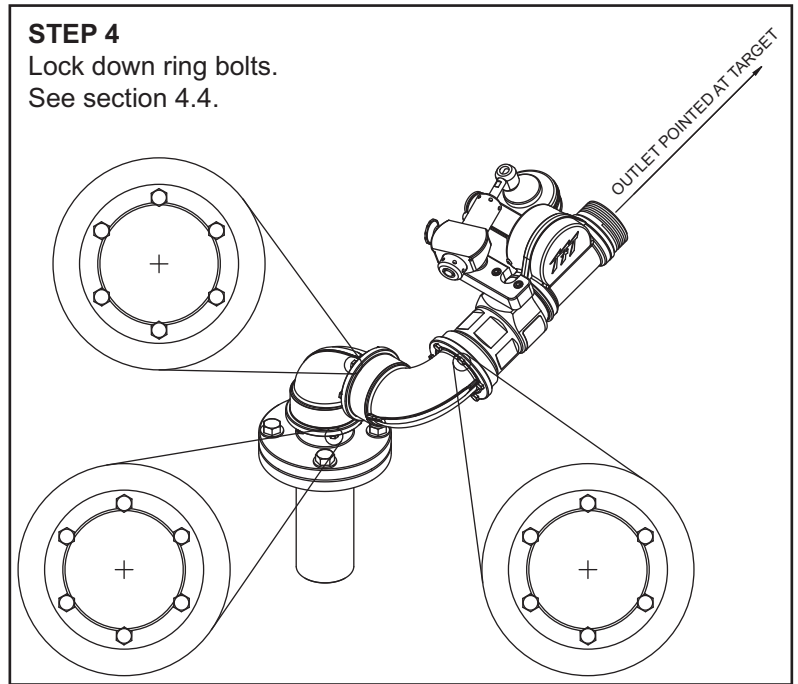

Figure 4.3 D

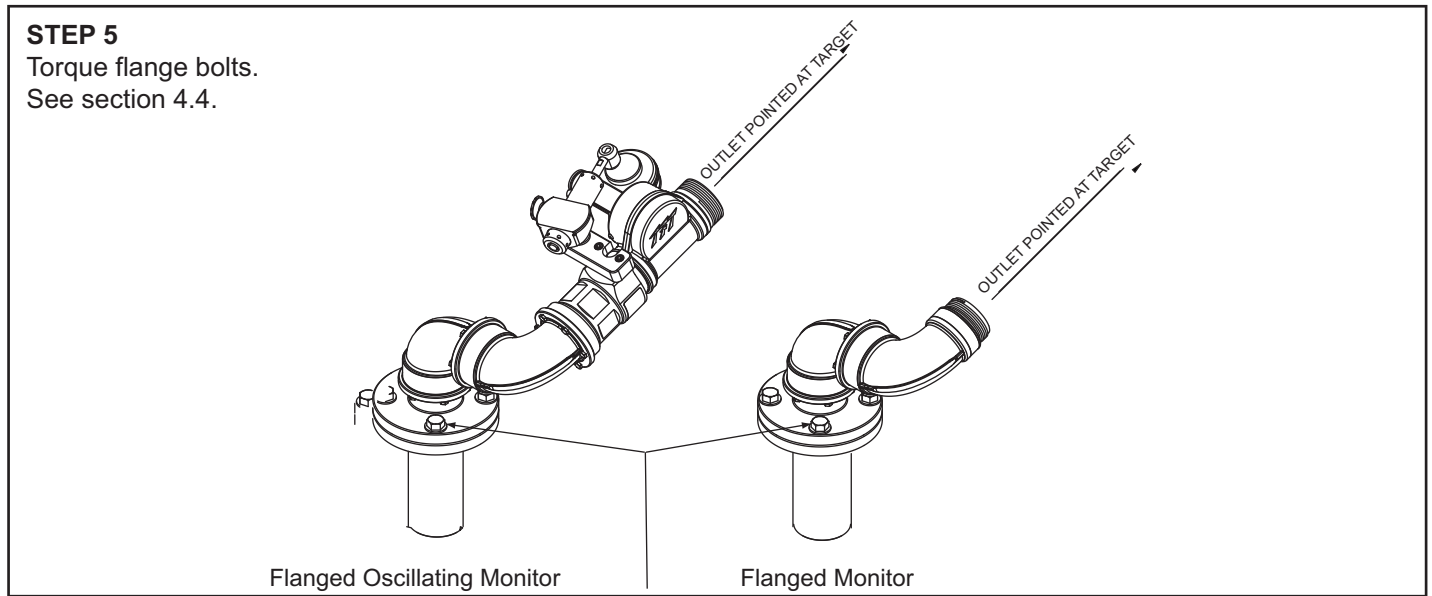

Figure 4.3 E

4.4 LOCKING THE MONITOR



Operation with unsecured bolts can cause a sudden change of monitor position, resulting in injury from an out of control stream. The Flanged Monitor is shipped from the factory with the bolts unlocked and ready for installation. Do not operate the Flanged Monitor until the locking bolts have been secured.

To lock the device:

1. Rotate the elbows so the nozzle is pointed at the desired target.
2. Snug up the ring bolts finger tight until they are all in contact.
3. Tighten the hex bolts ½ turn using a 7/16" (11mm) wrench.
4. Tighten bolts in the alternating pattern shown. Do not tighten the ring bolts past 1/2 turn.
5. The nozzle is simply screwed onto the monitor's exit threads.

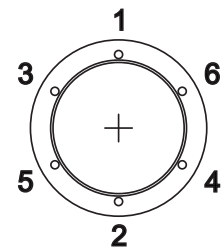

Figure 4.4

4.5 NOZZLE INSTALLATION

The nozzle is simply screwed onto the monitor's exit threads.

CAUTION

Mismatched or damaged waterway connections may cause equipment to leak or uncouple under pressure. Failure could result in injury. Equipment must be mated to matched connections.

CAUTION

Dissimilar metals coupled together can cause galvanic corrosion that can result in the inability to uncouple the connection, or complete loss of engagement over time. Failure could cause injury. Per NFPA 1930, if dissimilar metals are left coupled together, an anti-corrosive lubricant should be applied to the connection and the coupling should be disconnected and inspected at least quarterly.

4.6 DRAINING RESIDUAL WATER

There is no drain on the Flanged Monitor itself. A drain valve should be installed on the piping to which the monitor is attached.

WARNING

Monitors, valves, and piping may be damaged if frozen while containing sufficient amounts of water. Such damage may be difficult to detect visually and can lead to possible damage, injury, or death. Equipment that may be exposed to freezing conditions must be drained immediately following use to prevent damage.

CAUTION

Structural damage from corrosion can result from failure to drain appliance between uses. Damage from corrosion can cause injury due to equipment failure. Always drain appliance between uses.

5.0 OPERATION OF OSCILLATING MONITORS

DANGER

Modifying this oscillating mechanism to fit any other monitor will cause the reaction force of the nozzle to be unaligned with the center of rotation. An unaligned monitor may spin very fast with a very high force, which can result in serious injury or death. Do not modify the oscillator to fit any other monitor.

5.1 TO ENGAGE THE OSCILLATING MECHANISM

If the nozzle moves freely left to right by hand, the oscillating mechanism is not engaged. To engage, ensure the black knob on the side of the oscillator is released, and move the nozzle from one side to the other until the black knob clicks into the groove on the spring canister. The minimum flow required to oscillate is 175 gpm (650 L/min).

The oscillating mechanism is equipped with a safety device that prevents damage to the gear train in case the oscillator comes in contact with an object. The safety device will allow the mechanism to continue to oscillate the portion of its sweep path not blocked by the obstruction. The safety mechanism also allows the oscillating mechanism to sweep vertically without disengaging the oscillator. Once obstruction is removed, sweep pattern will return to normal.

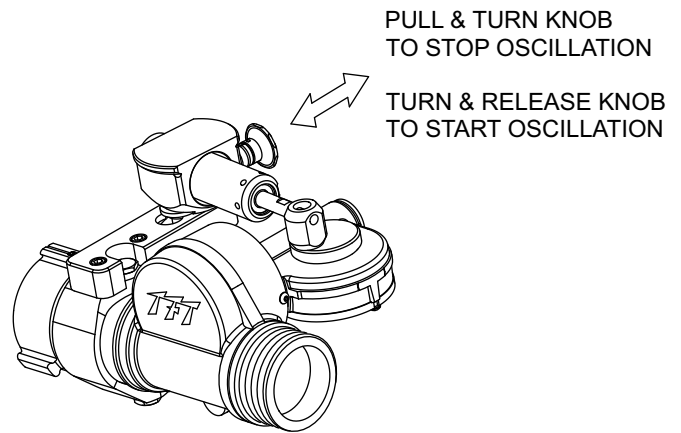

Figure 5.1

CAUTION

The oscillator unit contains moving parts that can pinch fingers and hands when the unit is in operation. Keep hands and fingers away from the moving parts of the oscillating unit when water is flowing.

5.2 TO DISENGAGE THE OSCILLATING MECHANISM

To operate the oscillating monitor manually, pull then twist the black knob located on the side of the monitor. Twisting will lock the knob in the disengaged position. The crank, rod, and spring canister will continue to move. Move the nozzle to the desired position by hand.

5.3 COVERAGE AREA OF THE OSCILLATING MONITOR

CAUTION

Because the nozzle attached to the oscillator must slow down, stop and reverse direction at the end of each sweep, the ends of the covered area will receive more water than the center. If the center area of coverage needs the most cooling, occasionally narrow the area of coverage or use the oscillator manually.

NOTICE

The type of nozzle and flow pressure are critical to the coverage area. The graph shows coverage area based on the movement capability of the oscillating mechanism. Actual coverage will depend on flow, pressure, type of nozzle, angle of fog pattern, and wind conditions.

To adjust the area of coverage, refer to Figure 5.3. Engage the oscillating mechanism once the desired angle has been set.

Oscillation speed: The chart shows how many times per minute the oscillator makes one complete cycle as a function of flow. The higher the flow, the faster it oscillates.

Nozzle reach: Refer to the operating manual for the specific nozzle. For reach with oscillation, subtract 20% from the distance.

APPROXIMATE CYCLES/MIN	GPM	L/min
8	175	650
13	250	1000
21	375	1500
28	500	2000

OSCILLATION SPEED

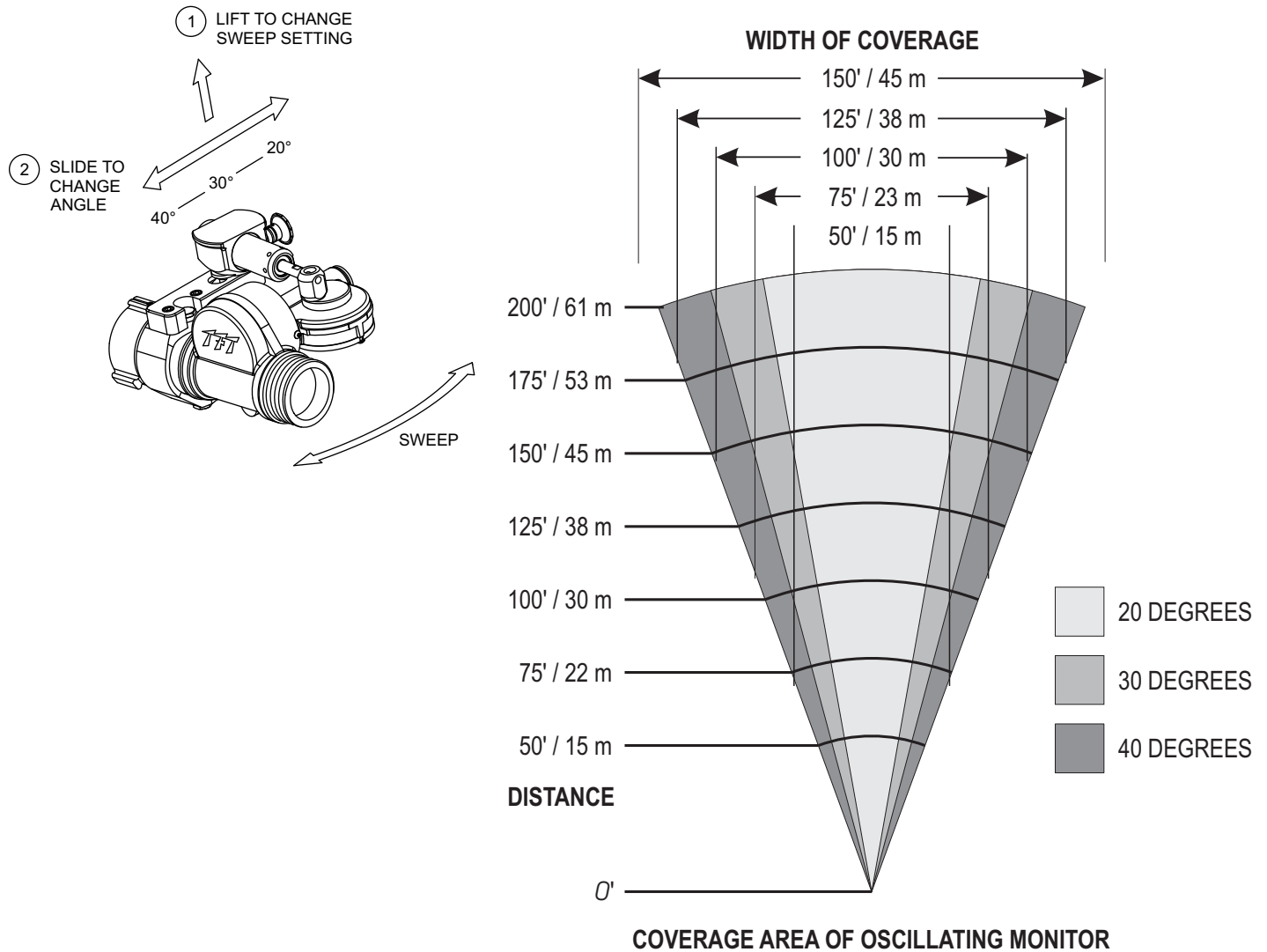

Figure 5.3

6.0 FLOW CHARACTERISTICS

6.1 FRICTION LOSS

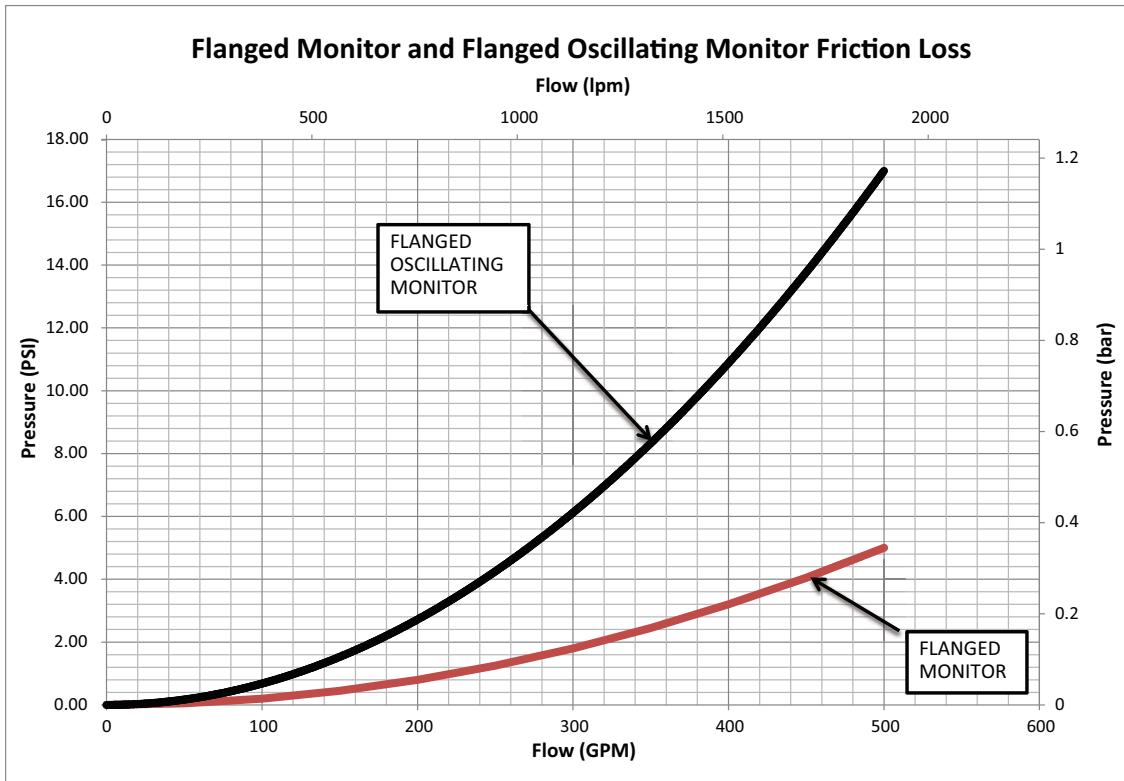

Figure 6.1

7.0 WARRANTY

Go to tft.com for all warranty information.

8.0 MAINTENANCE

TFT products are designed and manufactured to be damage resistant and require minimal maintenance. However, as the primary firefighting tool upon which your life depends, it should be treated accordingly. The unit should be kept clean and free of dirt by rinsing with water after each use. Any inoperable or damaged parts should be repaired or replaced before placing the unit in service. To help prevent mechanical damage, do not drop or throw equipment.

In applications where appliances are left continuously connected to the apparatus or other devices or are used where water is trapped inside the appliance, the appliance must be flushed with fresh water following each use and inspected for damage.

This appliance should be disconnected, cleaned and visually inspected inside and out at least quarterly, or as water quality and use may require. Moving parts such as handles, valve ball and couplings should be checked for smooth and free operation. Seals shall be greased as needed with Silicone based grease such as Molykote 112. Any scrapes that expose bare aluminum should be cleaned and touched up with enamel paint such as Rust-Oleum. Replace any missing or damaged parts before returning to service.

Any equipment taken out of service due to failure should be returned to the factory for repair or replacement. If you have any questions regarding the testing or maintenance of your valve, please call Task Force Tips at 800-348-2686.

8.1 SERVICE TESTING

In accordance with NFPA 1930, equipment must be tested a minimum of annually. Units failing any part of this test must be removed from service, repaired and retested upon completion of the repair.

8.2 REPAIR

Factory service is available. Factory serviced equipment is repaired by experienced technicians, wet tested to original specifications, and promptly returned. Call TFT service department at 1-800-348-2686 to troubleshoot and, if needed, directions for return. A return for service form can also be obtained at tft.com/Support/Returning-an-Item-for-Service.

Repair parts and service procedures are available for those wishing to perform their own repairs. Task Force Tips assumes no liability for damage to equipment or injury to personnel that is a result of user service. Contact the factory or visit the web site at tft.com for parts lists, exploded views, test procedures and troubleshooting guides.

Performance tests shall be conducted on the equipment after a repair, or anytime a problem is reported to verify operation in accordance with TFT test procedures. Consult factory for the procedure that corresponds to the model and serial number of the equipment. Any equipment which fails the related test criteria should be removed from service immediately. Troubleshooting guides are available with each test procedure or equipment can be returned to the factory for service and testing.



It is the responsibility of service technicians to ensure the use of appropriate protective clothing and equipment. The chosen protective clothing and equipment must provide protection from potential hazards users may encounter while servicing equipment. Requirements for protective clothing and equipment are determined by the Authority Having Jurisdiction (AHJ).



Any alterations to the product or its markings could diminish safety and constitutes a misuse of this product.



All replacement parts must be obtained from the manufacturer to assure proper performance and operation of the device.

9.0 EXPLODED VIEWS AND PARTS LISTS

Exploded views and parts lists are available at tft.com/serial-number.

10.0 OPERATION AND INSPECTION CHECKLIST

BEFORE EACH USE, appliances must be inspected to this checklist:

1. Waterway is clear of obstructions.
2. There is no damage to any thread or other connection.
3. Gaskets are in good repair.
4. There is no obvious damage such as missing, broken or loose parts.
5. There is no damage to the appliance that could impair safe operation (e.g. dents, cracks, corrosion, or other defects).
6. Nozzle is securely attached.

BEFORE BEING PLACED BACK IN SERVICE, appliances must be inspected to this checklist:

1. The waterway is clear of obstructions.
2. There is no damage to any thread or other type connection.
3. Gaskets are in good repair.
4. There is no obvious damage such as missing, broken or loose parts.
5. There is no damage to the appliance that could impair safe operation (e.g. dents, cracks, corrosion, or other defects).
6. Nozzle is securely attached.
7. All markings are legible.
8. There are no missing, broken, or worn lugs on couplings.



Equipment failing any part of the checklist is unsafe for use and must have the problem corrected before use or being placed back into service. Operating equipment that has failed the checklist is a misuse of this equipment.