

INSTRUCTIONS FOR OPERATION AND MAINTENANCE

⚠ DANGER

Understand manual before use. Operation of this device without understanding the manual and receiving proper training is a misuse of this equipment. Obtain safety information at tft.com/ serial-number.

This equipment is intended for use by trained and qualified emergency services personnel for firefighting. All personnel using this equipment shall have completed a course of education approved by the Authority Having Jurisdiction (AHJ).

This instruction manual is intended to familiarize firefighters and maintenance personnel with the operation, servicing, and safety procedures associated with this product. This manual should be kept available to all operating and maintenance personnel.

MAXIMUM OPERATION PRESSURE
175 PSI (12 bar)

MAXIMUM FLOW
500 GPM (2000 l/min)

HYDROSTATIC PROOF TEST
900 PSI (62 BAR) per NFPA 1964

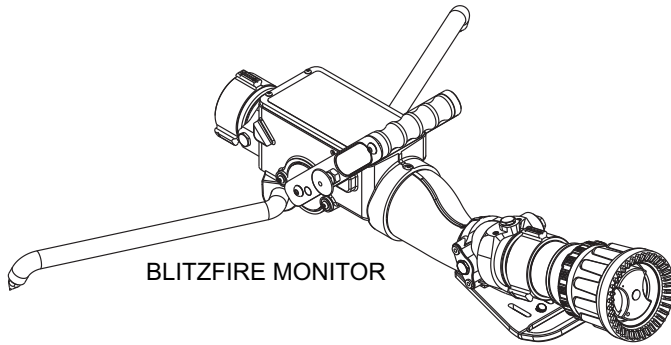

BLITZFIRE MONITOR

BLITZFIRE®

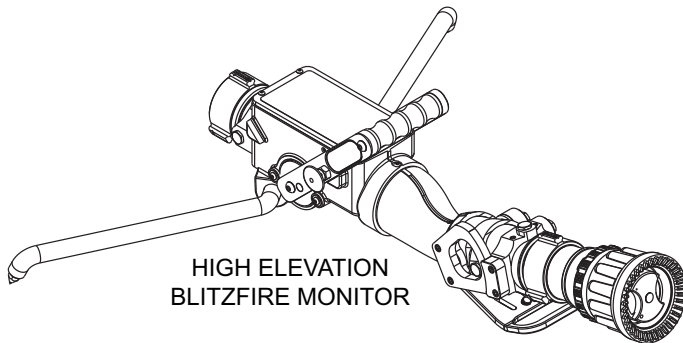

HIGH ELEVATION
 BLITZFIRE MONITOR

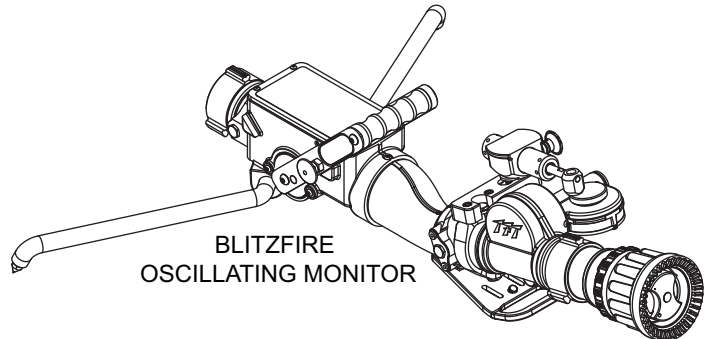

BLITZFIRE
 OSCILLATING MONITOR

BLITZFIRE® OSC

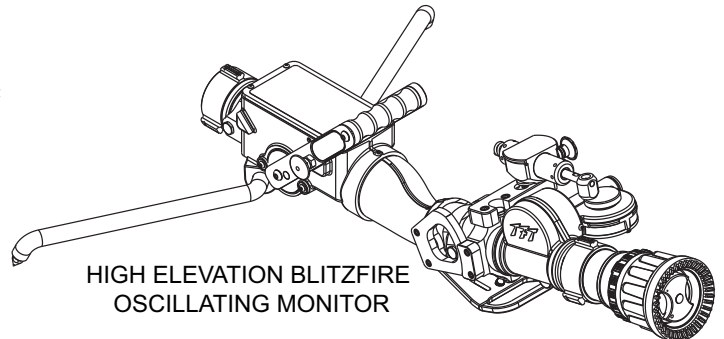

HIGH ELEVATION BLITZFIRE
 OSCILLATING MONITOR

DANGER

PERSONAL RESPONSIBILITY CODE

The member companies of FEMSA that provide emergency response equipment and services want responders to know and understand the following:

1. **Firefighting and Emergency Response are inherently dangerous activities requiring proper training in their hazards and the use of extreme caution at all times.**
2. **IT IS YOUR RESPONSIBILITY to read and understand any user's instructions, including purpose and limitations, provided with any piece of equipment you may be called on to use.**
3. **IT IS YOUR RESPONSIBILITY to know that you have been properly trained in Firefighting and/or Emergency Response and in the use, precautions, and care of any equipment you may be called upon to use.**
4. **IT IS YOUR RESPONSIBILITY to be in proper physical condition and to maintain the personal skill level required to operate any equipment you may be called upon to use.**
5. **IT IS YOUR RESPONSIBILITY to know that your equipment is in operable condition and has been maintained in accordance with the manufacturer's instructions.**
6. **Failure to follow these guidelines may result in death, burns or other severe injury.**

Fire and Emergency Manufacturers and Service Association, Inc.
PO Box 147, Lynnfield, MA 01940 • www.FEMSA.org



© 2020 FEMSA. All Rights Reserved.

SUPPORTING MATERIALS

The following documents contain supporting safety and operating information pertaining to the equipment described in this manual.

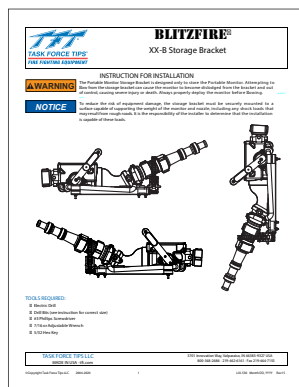

LIX-635 - BLITZFIRE XX-B Storage Bracket

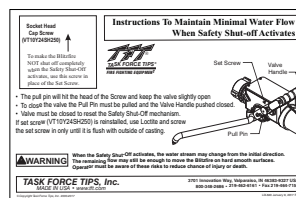





LIX-640 - Instructions to Maintain Water Flow when Safety Shut-off Activates

TABLE OF CONTENTS









- 1.0 MEANING OF SAFETY SIGNAL WORDS
- 2.0 SAFETY
- 3.0 GENERAL INFORMATION
 - 3.1 SPECIFICATIONS
 - 3.2 OPERATING ENVELOPE
 - 3.3 USE WITH SALT WATER
 - 3.4 VARIOUS MODELS AND TERMS
 - 3.4.1 BLITZFIRE MONITOR
 - 3.4.2 OSCILLATOR
- 4.0 OPERATING INSTRUCTIONS
 - 4.1 FLOW CONTROL VALVE OPERATION
 - 4.2 SAFETY SHUT-OFF VALVE OPERATION
 - 4.2.1 SAFETY SHUT-OFF VALVE TEST
 - 4.2.2 MANUAL OVERRIDE OF SAFETY SHUT-OFF VALVE
 - 4.2.3 SLOW CLOSE FEATURE
 - 4.3 FOLDING LEGS
 - 4.3.1 CARBIDE SPIKES
 - 4.4 PIVOTING INLET
 - 4.5 OUTLET PIVOTS
 - 4.6 ELEVATION HOLDING MECHANISM
- 5.0 FLOW CHARACTERISTICS
 - 5.1 AUTOMATIC, FIXED, AND SELECTABLE FLOW NOZZLES
 - 5.2 STACKED TIPS OR SMOOTH BORE NOZZLES
 - 5.3 STREAM STRAIGHTENERS
 - 5.4 USE WITH FOAM
 - 5.5 PRESSURE LOSS
- 6.0 DEPLOYMENT OF BLITZFIRE PORTABLE MONITOR
 - 6.1 CARRYING WITH AN UNCHARGED HOSE
 - 6.2 ADVANCING WITH A CHARGED HOSE
- 7.0 ANCHORING
 - 7.1 ANCHORING BY WEIGHT
 - 7.2 ANCHORING BY SPIKE HOLDS
 - 7.3 ANCHORING BY HOOKING LEGS
 - 7.4 ANCHORING BY USING THE TIE DOWN STRAP
- 8.0 OSCILLATING UNIT
 - 8.1 SAFETY - OSCILLATOR
 - 8.2 GENERAL - OSCILLATOR
 - 8.3 OPERATION - OSCILLATOR
 - 8.4 OSCILLATION SPEED AND COVERAGE
- 9.0 STORAGE
- 10.0 WARRANTY
- 11.0 MAINTENANCE
 - 11.1 SERVICE TESTING
 - 11.2 REPAIR
- 12.0 EXPLODED VIEW AND PARTS LISTS
- 13.0 OPERATION AND INSPECTION CHECKLIST

1.0 MEANING OF SAFETY SIGNAL WORDS

A safety related message is identified by a safety alert symbol and a signal word to indicate the level of risk involved with a particular hazard. Per ANSI Z535.6, the definitions of the four signal words are as follows:

	DANGER indicates a hazardous situation which, if not avoided, will result in death or serious injury.
	WARNING indicates a hazardous situation which, if not avoided, could result in death or serious injury.
	CAUTION indicates a potentially hazardous situation which, if not avoided, could result in minor or moderate injury.
	NOTICE is used to address practices not related to physical injury.

2.0 SAFETY

	An inadequate supply of pressure and/or flow will cause an ineffective stream and can result in injury or death. Choose operating conditions to deliver adequate fire suppression. See flow graphs.
	Sudden change in position of an improperly secured monitor can result in an out of control monitor. An out of control monitor can spray water in unintended directions or become a projectile, causing serious injury or death. To reduce the risk of an out of control monitor: <ul style="list-style-type: none">• Do not attempt to move the monitor while flowing• Keep elevation as high as practical• Test Shut-off valve before each use• Securely tie off monitor to an immovable object• Ensure all legs are in the unfolded position• Hook legs on stationary objects such as door frames, sign posts, etc.• Choose surfaces that allow all spikes to contact the ground• Do not place the monitor on top of debris, objects, or uneven terrain• Assure that the hose is not lifting spikes off the ground• If stability is questionable, reduce flow to limit reaction In the event of an out of control monitor: <ul style="list-style-type: none">• Immediately retreat to a safe distance• Shut down the water hose at its source before attempting to re-secure the monitor
	Interrupting flow to the monitor could cause injury or death. Avoid situations that may interrupt flow to the monitor such as hose line kinks, traffic running over hose, and automatic doors or devices that can pinch the hose.
	The stream exiting a nozzle is very powerful and capable of causing injury and property damage. Make sure the nozzle is securely attached and pointing in a safe direction before water is turned on. Do not direct water stream to cause injury or damage to persons or property.
	Equipment may be damaged if frozen while containing significant amounts of water. Such damage may be difficult to detect visually. Subsequent pressurization can lead to injury or death. Any time the equipment is subject to possible damage due to freezing, it must be tested and approved for use by qualified personnel before being considered safe for use.
	Mismatched or damaged waterway connections may cause equipment to leak or uncouple under pressure. Failure could result in injury. Equipment must be mated to matched connections.
	Dissimilar metals coupled together can cause galvanic corrosion that can result in the inability to uncouple the connection, or complete loss of engagement over time. Failure could cause injury. Per NFPA 1962, if dissimilar metals are left coupled together, an anti-corrosive lubricant should be applied to the connection and the coupling should be disconnected and inspected at least quarterly.
	To prevent mechanical damage, do not drop or throw equipment.

3.0 GENERAL INFORMATION

The BLITZFIRE is a simple, light and easy to maneuver portable monitor. This monitor can be mounted in a preconnected state on the truck-mounting storage bracket for achieving quick and effective initial attack. The monitor has a revolutionary Safety Shut-Off Valve, which will shut-off the water flow in the event of sudden movement by the monitor. This safety feature reduces the risk of injury from an out of control master stream device.

3.1 SPECIFICATIONS

Size (legs folded) (BLITZFIRE & BLITZFIRE-HE)	29.5" x 8.1" x 8.5"	(74.9 x 20.6 x 21.6 cm)
Weight (without nozzle) (BLITZFIRE & BLITZFIRE-HE)	24.5 lbs	(11.1 kg)
Size (legs folded) (BLITZFIRE OSC & BLITZFIRE-HE OSC)	37.3" x 10.5" x 9.5"	(94.7 x 26.7 x 24.4 cm)
Weight (without nozzle) (BLITZFIRE OSC & BLITZFIRE-HE OSC)	32 lbs	(14.5 kg)
Maximum inlet pressure with valve shut off	300 psi	(20 bar)
Maximum inlet pressure flowing	175 psi	(12 bar)
Flow Range	up to 500 gpm	(up to 2000 l/min)
Operating temperature of fluid	33 to 120°F	(1 to 50°C)
Storage temperature range	-40 to 150°F	(-40 to 65°C)
Standard Inlet Coupling	2 1/2" NH Female	
Standard Outlet	2 1/2" NH Male	
Vertical Stream Range	10° to 46° or 86° above horizontal	
Horizontal Stream Range	+/- 20° either side of centerline	
Materials used	Aluminum 6000 series hard anodized MIL8625 class 3 type 2, stainless steel 300 series, nylon 6-6	

Table 3.1

3.2 OPERATING ENVELOPE



Damage or injury could result from operating the monitor beyond the safe operating envelope. Do not operate the monitor outside the envelope in the following graph(s).

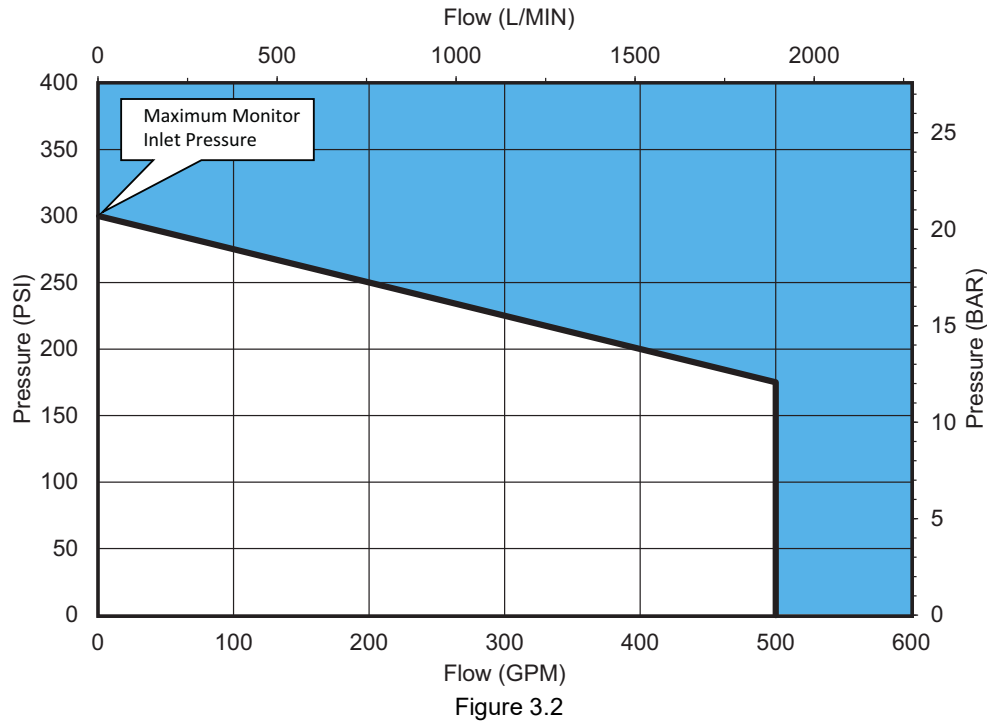

Figure 3.2

3.3 USE WITH SALT WATER

Use with salt water is permissible provided the equipment is thoroughly cleaned with fresh water after each use. The service life of the equipment may be shortened due to the effects of corrosion, and is not covered under warranty.

3.4 VARIOUS MODELS AND TERMS

3.4.1 BLITZFIRE MONITOR

The BLITZFIRE monitor is available in standard and high elevation models. Figure 3.4.1 identifies the various parts and controls on a standard BLITZFIRE portable monitor. Parts and controls for a high elevation model are similar.

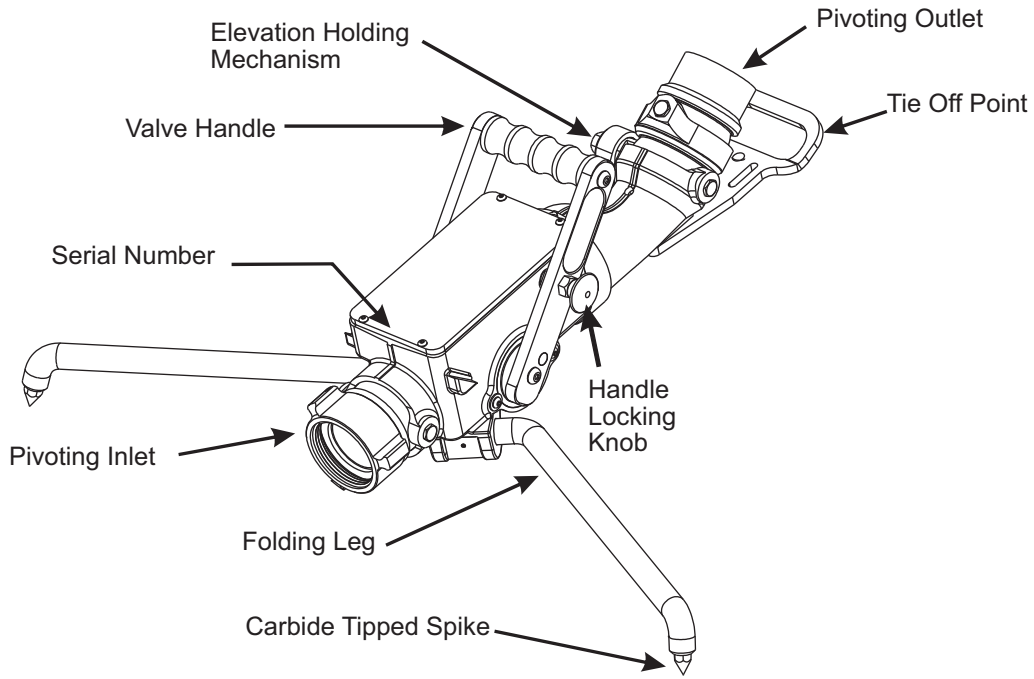

Figure 3.4.1

3.4.2 OSCILLATOR

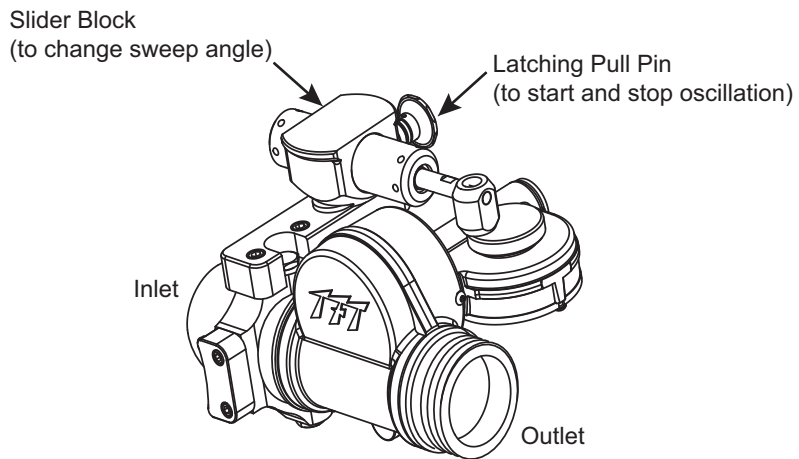

Figure 3.4.2

4.0 OPERATING INSTRUCTIONS

4.1 FLOW CONTROL VALVE OPERATION

The BLITZFIRE valve is used to control the flow and acts as a safety shut-off feature. The valve is shut-off when the valve handle is fully forward. The valve is fully on when the valve handle is fully back. The valve can be opened to any of six detented flow positions. These detented positions allow the monitor operator to regulate the flow depending on the need or what can be safely and effectively handled.

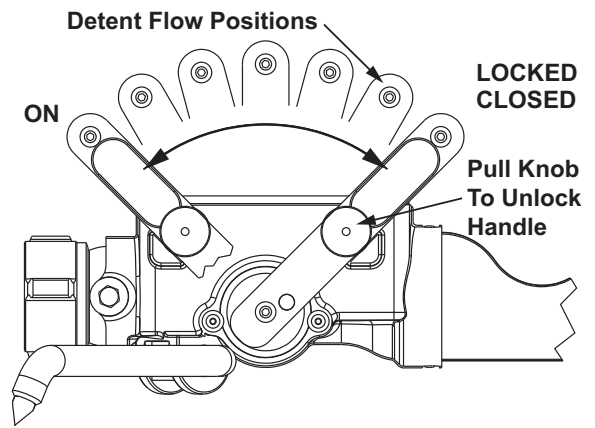

Figure 4.1A

The valve handle is locked in the closed position so that the portable monitor may be carried/moved without the valve inadvertently opening when water flow is not desired. To unlock the valve handle from the closed position:

1. Pull the knob on the right side of the valve handle.
2. While pulling the knob, use the other hand to move the valve handle slowly to an open position.

As soon as valve is opened the knob may be released. Valve handle may be moved to any detent position by pushing or pulling on the valve handle. When the valve is closed the valve handle automatically locks and must be unlocked to reopen. The monitor has a label that indicates the direction to open and close the valve.

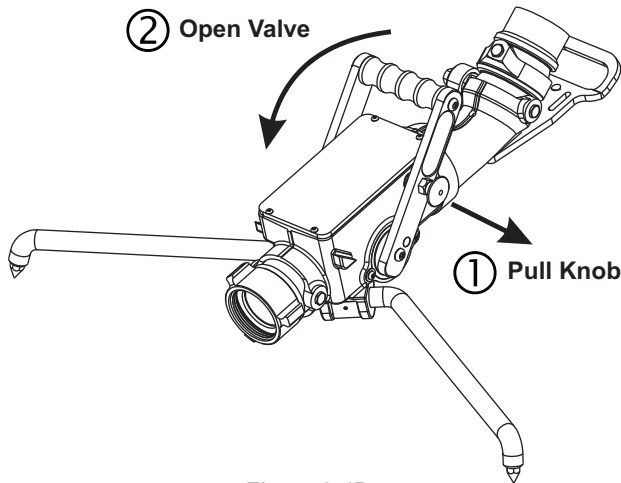

Figure 3.4B

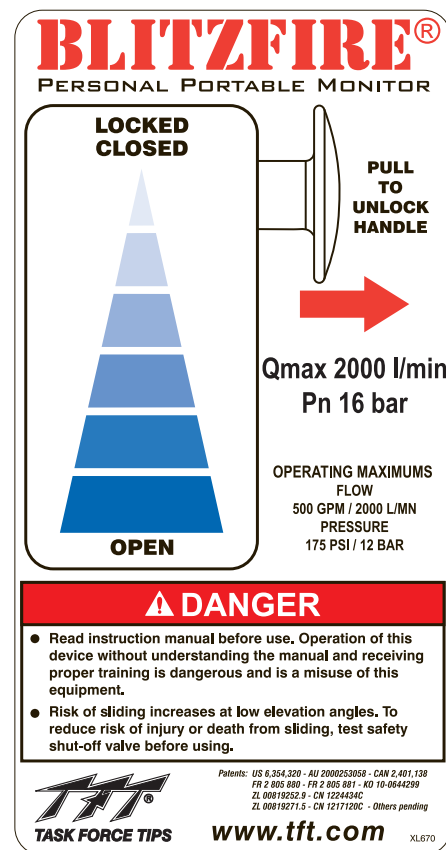

Figure 3.4C



WARNING Sudden changes in valve position can cause pressure spikes (water hammer) and could lead to hose or pipe failure or an out of control monitor. Open and close the valve slowly to avoid water hammer.

4.2 SAFETY SHUT-OFF VALVE OPERATION

The BLITZFIRE is equipped with a Safety Shut-Off Valve. The Safety Shut-Off Valve will shut off the flow to the monitor if the monitor starts to move. The Safety Shut-Off Valve relies on acceleration of the BLITZFIRE as the signal to activate. It activates at approximately one G of sideways acceleration. Placing the BLITZFIRE on tilted surfaces (greater than 10 degrees) may inhibit the resetting of the Safety Shut-Off Valve. The hose connected to the BLITZFIRE should contain any forward or backwards motion to safe levels.

WARNING

The Safety Shut-Off Valve requires approximately one G of sideways acceleration to activate. Forward and backward movement alone will not activate the Safety Shut-Off Valve. At low accelerations, the monitor may travel several yards (meters) and gain enough velocity to cause injury before the safety shutoff activates.

To reduce the risk of unlimited movement:

- Always keep the hose directly behind the monitor.
- Never loop the hose in front of the monitor.
- Always tie the monitor off securely.

To reduce the risk of personal injury from a moving/sliding monitor:

- Keep personnel out of the potential path of a moving/sliding monitor.

WARNING

Improper repairs may result in a malfunctioning Safety Shut-Off Valve, which could result in serious injury or death. Always return the monitor to Task Force Tips for any repairs to the safety shut-off valve.

Safety Shut-Off Valve operation:

1. Set up the monitor and charge the hose.
2. Point the nozzle in the desired direction.
3. Open the valve by pulling the locking pin and pulling back on the valve handle.
4. Place the handle in the desired detent position (further back for more flow, further forward for less).
5. If the monitor starts to slide, the safety valve will sense the movement and release the valve.
 - An internal spring and water pressure will move the valve handle forward to the closed position and shut off the water flow.
 - The valve handle will lock in the closed position.
6. After the cause of the sliding has been corrected, assure the valve is fully closed and reopen the valve as described in Step 3.

If the Safety Shut-Off Valve fails to reset, the valve will not remain open. Failure to reset may be due to placing the monitor on an excessively sloped surface.

The Safety Shut-Off Valve is set at the factory to completely shut off the flow when tripped. To change the shut-off to reduce the flow rather than perform a complete shut off, see the enclosed card, "Instructions to Maintain Minimal Water Flow When the Safety Shut-Off Activates" (LIX-640), or contact customer service at tft.com.

NOTICE

Valve must be fully closed to reset the safety shut-off valve mechanism. Once tripped, the valve handle will not stay open unless the mechanism is reset by fully closing the valve.

4.2.1 SAFETY SHUT-OFF VALVE TEST

WARNING

The Safety Shut-Off Valve is intended to shut off the monitor when it detects sudden sideways movement. It cannot prevent movement, but is intended to limit motion. To reduce the risk of severe injury or death:

- Test the safety shut-off operation before each use.
- Always use adequate means to secure the monitor to reduce movement.

With hose uncharged and BLITZFIRE on a level surface:

1. Open the Valve Handle to the fully open position.
2. Grasp the monitor and give it a sideways jerk, rotate the monitor sideways, or hit the monitor on the side with a rubber mallet.
3. Safety valve proper function is indicated by the valve handle moving toward the closed position. NOTE - With water flowing, the valve has additional forces on it that will move the valve to the fully closed position.

If the Safety Shut-Off Valve fails this test, return the monitor to Task Force Tips to restore proper functioning of the valve. Using the monitor without a properly functioning Safety Shut-Off valve is a misuse of the product.

4.2.2 MANUAL OVERRIDE OF SAFETY SHUT-OFF VALVE

On sloping terrain it may be necessary to manually override the Safety Shut-Off Valve. The Safety Shut-Off Valve can be overridden by the operator manually holding the valve handle in an open position.

WARNING

Overriding the Safety Shut-Off Valve requires the monitor to be manned. Tampering with the valve handle will render the Safety Shut-Off Valve inoperable and could result in injury or death. Never tie or prop open the valve handle.

4.2.3 SLOW CLOSE FEATURE

The BLITZFIRE has a valve damping mechanism to slow valve closure as it approaches OFF, to reduce the effects of water hammer. The damping mechanism has a vane moving in dampening fluid connected to the valve handle on the left side of the monitor.



Improper servicing of the slow close device may result in a malfunctioning Safety Shut-Off Valve, which could cause injury or death. If service is needed on the slow close device, contact Task Force Tips. Do not add or change dampening fluid.



Water Hammer occurs any time a valve is closed when water is flowing. This can cause sudden movement or ruptured hose lines, which could result in injury or death. The dampening device in the Blitzfire monitor reduces the effects of water hammer, but DOES NOT ELIMINATE IT! All personnel should adhere to procedures approved by the AHJ to avoid risk when near any hose that might be shut off quickly.

4.3 FOLDING LEGS

The BLITZFIRE Portable Monitor has two legs that fold for storage and unfold for operation. The legs are held in the folded and unfolded position by spring detents. To fold or unfold the legs:

1. Grasp the spike end of one leg and pivot it to the folded or unfolded position.
2. Repeat for the other leg.



In the unfolded position, the legs provide a stable base for operation of the monitor. Lack of stability can cause an out of control monitor resulting in injury or death. Do not operate as a portable monitor with one or both legs in the folded position.

4.3.1 CARBIDE SPIKES

The BLITZFIRE Portable Monitor has 3 tungsten carbide tipped spikes on the legs and the base to resist sliding by digging into the surface the monitor is sitting on. The amount of sliding force these spikes can withstand depends upon the amount of downward and sideways force that is on the base, and the hardness and texture of the surface the spikes are in contact with. At low elevation angles, it is difficult for these spikes to resist sliding. These spikes are essential to safe operation of the monitor and must be in contact with the ground at all times. Set the monitor on an even surface so that all three spikes contact the ground. Replace any spike if the tip diameter exceeds 1/16 inch (1.6mm). Contact TFT to order Replacement Spike Kit XX482-KIT.



For stable operation all spikes must maintain contact with the ground. Lack of stability can cause an out of control monitor resulting in injury or death. Do not place the monitor on top of debris, objects, or uneven terrain that could keep any of the spikes from contacting the ground.



On hard slippery surfaces the spikes may provide little resistance to sliding. A sliding monitor may become out of control and may cause injury or death.

To help increase resistance to sliding:

- Tie off the monitor
- Hook the legs on a stationary object
- Apply a person's weight to the monitor
- Replace any spike if the tip diameter exceeds 1/16 inch (1.6 mm)



Spikes are sharp and exposed. Use care around spikes to avoid injury and damage to clothing or other property.

4.4 PIVOTING INLET

The BLITZFIRE has a pivoting inlet so that different size hoses can be used without lifting the spikes off the ground. The pivoting inlet also allows the monitor to be positioned on porches, stair landings, and the like. The pivot moves up and down 20 degrees. The BLITZFIRE is equipped with three spikes to provide traction when flowing from the ground. For the spikes to provide traction, they must remain in contact with the ground.

4.5 OUTLET PIVOTS

The monitor's outlet pivots allow for 20 degrees of horizontal rotation either side of center. The elevation range is from 10 to 46 or 86 degrees unmanned. Push or pull on the nozzle to redirect the stream. The pivots are easy to reposition under pressure and are good for rapid redirecting of the stream. However, if the pivot is rapidly bumped against its travel limit, the Safety Shut-Off Valve may activate and shut off the monitor. The BLITZFIRE has been designed to operate at very low elevation angles to maximize usefulness for interior attack. As with any monitor, when the elevation angle is low the risk of sliding is increased. This is because at low elevation angles the reaction force is more horizontal and less vertical.

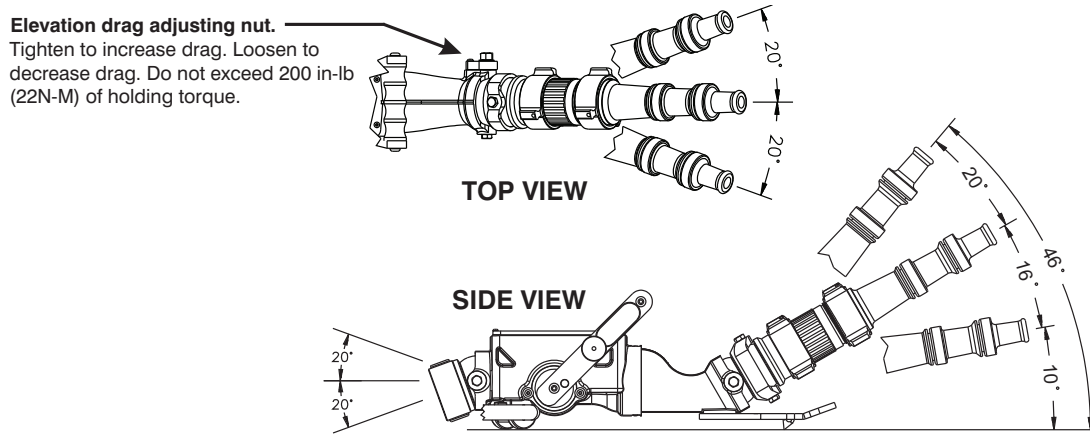

Figure 4.5A

Blitzfire Travel Range

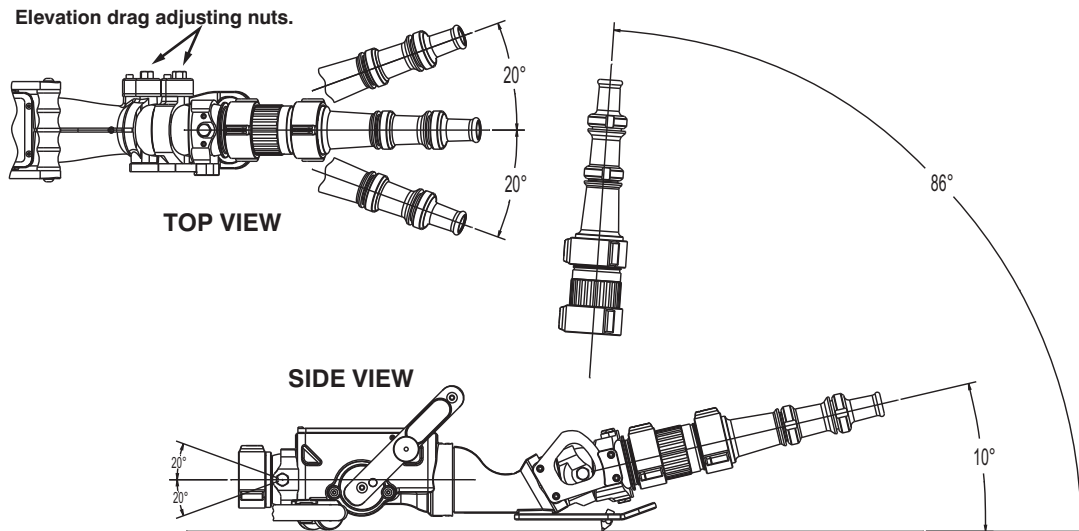

Figure 4.5B

Blitzfire HE (High Elevation) Travel Range

4.6 ELEVATION HOLDING MECHANISM

The elevation pivot has a mechanism to support the weight of a nozzle. It is factory set to support the weight of nozzles likely to be used. It may be adjusted. The mechanism releases when raising the nozzle so upwards drag from the mechanism is not felt. Avoid the use of long stream straighteners or heavy nozzles which may overcome the holding torque of the elevation mechanism.

NOTICE

Tighten the holding mechanism in small increments. Tighten only enough to compensate for the weight of the nozzle (and FoamJet, if applicable). Overtightening of the drag nut will cause damage or premature wear to the elevation holding mechanism.

5.0 FLOW CHARACTERISTICS

The BLITZFIRE Portable Monitor is designed for maximum flows of 500 GPM (2000 LPM) and a maximum pressure of 175 PSI (12 BAR). Do not exceed these limits.

5.1 AUTOMATIC, FIXED, AND SELECTABLE FLOW NOZZLES

A variety of water or foam nozzles may be used with the BLITZFIRE Portable Monitor.

Automatic nozzles maintain a constant pressure by adjusting their opening to match the available flow. Consult the nozzle manufacturer for maximum flow and pressure ratings. In all cases do not exceed 500 GPM (2000 LPM) and/or 175 PSI (12 BAR).

5.2 STACKED TIPS OR SMOOTH BORE NOZZLES

NOZZLE DIAMETER	NOZZLE INLET PRESSURE									
	50 PSI		80 PSI		100 PSI		150 PSI		175 PSI	
	FLOW (GPM)	REACTION (LBS)	FLOW (GPM)	REACTION (LBS)	FLOW (GPM)	REACTION (LBS)	FLOW (GPM)	REACTION (LBS)	FLOW (GPM)	REACTION (LBS)
1.0"	210	80	266	126	297	157	364	236	390	275
1-1/4"	328	120	415	196	464	245	---	---	---	---
1-1/2"	473	177	---	---	---	---	---	---	---	---

NOZZLE DIAMETER	NOZZLE INLET PRESSURE									
	4 BAR		6 BAR		8 BAR		10 BAR		12 BAR	
	FLOW (L/min)	REACTION (KG)	FLOW (L/min)	REACTION (KG)	FLOW (L/min)	REACTION (KG)	FLOW (L/min)	REACTION (KG)	FLOW (L/min)	REACTION (KG)
25mm	830	40	1000	60	1200	80	1300	100	1400	120
32mm	1300	70	1700	100	1900	130	---	---	---	---
38mm	1900	90	---	---	---	---	---	---	---	---

---	Flow exceeds rating of Blitzfire Portable Monitor
-----	--

Table 5.2

5.3 STREAM STRAIGHTENERS

Stream quality, especially with smooth bore nozzles, is improved with the use of a stream straightener. A stream straightener is integrated into the exit of the monitor.

5.4 USE WITH FOAM

The monitor may be used with various foam nozzles and foam solutions. Refer to fire service training for the proper use of foam.



For Class B fires, lack of foam or interruption in the foam stream can cause a break in the foam blanket and greatly increase the risk of injury or death. Follow procedures established by the AHJ for the specific fuel and conditions.



Improper use of foam or using the wrong type of foam can result in illness, injury, or damage to the environment. Follow foam manufacturer's instructions and fire service training as directed by the AHJ.



Use of compressed air foam (CAF) with portable monitors can cause sudden surges in nozzle reaction force resulting in risk of injury or death from hose whipping or an out of control monitor. Be prepared for sudden changes in nozzle reaction caused by:

- Slug loading (Loss of foam concentrate sends slugs of air and water into the nozzle)
- Sudden release of built-up pressure in the hose when opening a nozzle

5.5 PRESSURE LOSS

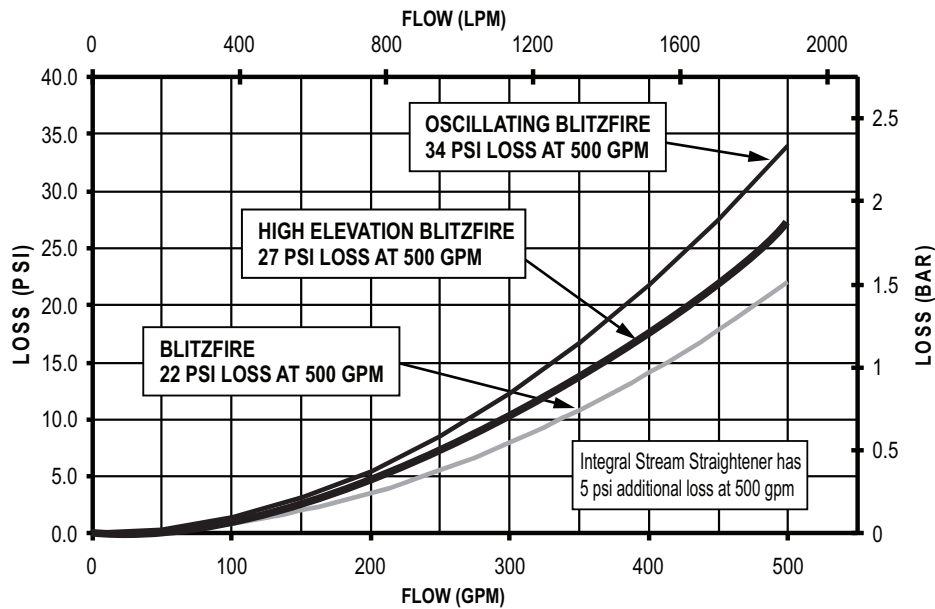

Figure 5.5A

6.0 DEPLOYMENT OF BLITZFIRE PORTABLE MONITOR

It is the responsibility of the individual fire department or agency to determine physical capabilities and suitability for an individual's use of this equipment.

6.1 CARRYING WITH AN UNCHARGED HOSE

On a preconnected hoseline the BLITZFIRE may be carried using the valve handle, front handle/tie off point, or over the shoulder with the legs folded as illustrated.



Figure 6.1

6.2 ADVANCING WITH A CHARGED HOSE

On a charged hose the BLITZFIRE may be advanced by holding the valve handle and one of the legs as shown. Valve handle should be locked in the closed position to keep the valve from inadvertently opening.



Figure 6.2

7.0 ANCHORING

The nozzle reaction force on the BLITZFIRE Portable Monitor may be as high as 330 lbs - 500 GPM at 175 PSI (150 kg- 2000 LPM at 12 BAR). This nozzle reaction must be restrained to keep the monitor from moving.

The monitor should be anchored from moving by one or more of these methods:

METHOD	RISK of MOVEMENT
Anchoring by Weight	HIGH
Anchoring by Spike Holds	MEDIUM
Hooking Legs on Vertical Surfaces	MEDIUM
Using the Tie Down Strap	LOW

Table 7.0

7.1 ANCHORING BY WEIGHT

On surfaces with good traction, a person's weight on the monitor and/or hose may be sufficient to keep the monitor from sliding. This is highly dependent on the friction of the surface. The ability to keep one or more people's weight on the monitor is subject to operator fatigue and may not be as reliable as other methods. Operating at limited flows will also reduce the risk of sliding.

7.2 ANCHORING BY SPIKE HOLDS

The holding ability of the spikes is generally excellent on surfaces like asphalt, wooden and carpeted floors because they allow the spike to penetrate well. On hard smooth surfaces such as ceramic tile, smooth concrete, marble, terrazzo, or steel decking the BLITZFIRE Portable Monitor's spikes may not hold well. Placing the spikes into cracks, expansion joints, gratings or the like will help hold the monitor from sliding. Even with the spikes anchored, sliding may be caused by the surface cracking under the load, or from the hose or nozzle moving the monitor thereby dislodging the spikes from their hold.

The holding ability of the spikes on soft surfaces such as sand, gravel and mud is generally poor. Other anchoring methods should be considered.

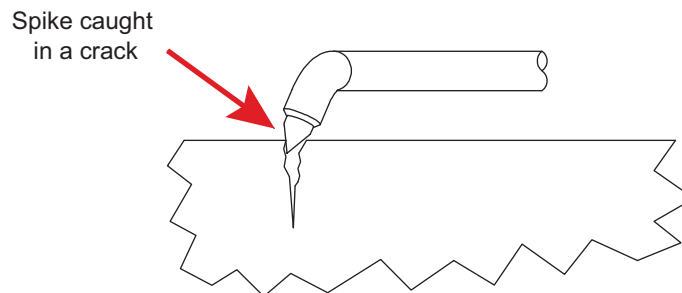

Figure 7.2

7.3 ANCHORING BY HOOKING LEGS

The legs on the BLITZFIRE Portable Monitor point back slightly so they can act as a hook for anchoring on posts, walls, door frames or other fixed objects. Sliding can occur if the legs are unhooked due to the influence of the hose, nozzle, or operator.

Anchoring by Hooking to a Post

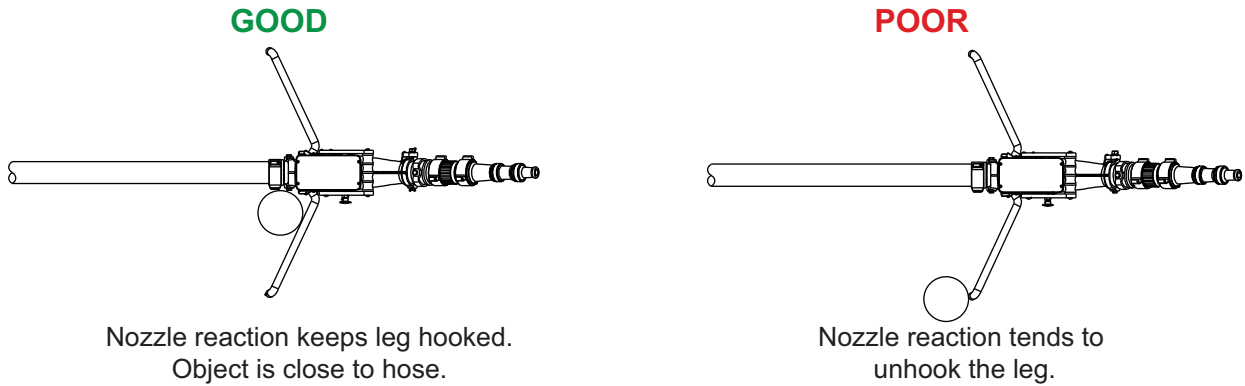

Figure 7.3A

Anchoring by Hooking to a Wall or Door Frame

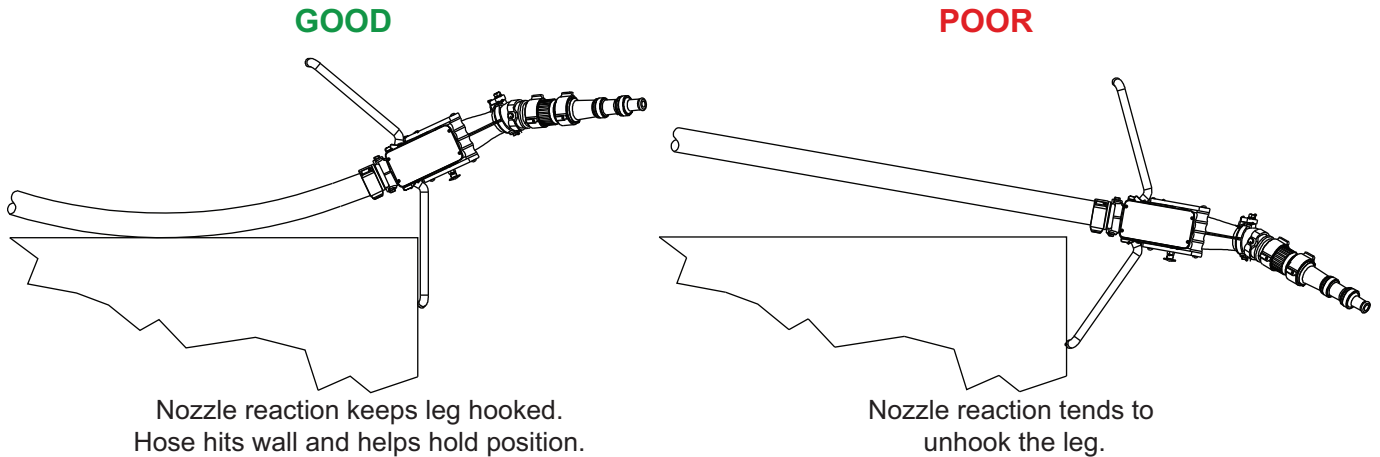

Figure 7.3B

7.4 ANCHORING BY USING THE TIE DOWN STRAP

The safest method of restraining the monitor is to use a tie down strap. It is inherently more reliable than other methods since it does not rely on traction or digging in of the spikes. It is also the safest method because even if the monitor slides, its travel is limited by the strap length. A forward attachment point and a strap are provided with the BLITZFIRE. A loop on the end of the strap may be placed over the anchor point or the strap may be wrapped around an object, such as a tree, and the snap end of the strap passed through the loop and pulled tight. Snap the hook into the hole in the carrying handle at the front of the BLITZFIRE. Keep the entire length of the strap as close to the ground as possible.

If the strap is too short to reach a suitable anchor, it may be extended with strong rope or chain. Keep the distance between the monitor and anchor as short as possible. Remove all slack between the monitor and anchor before flowing water.

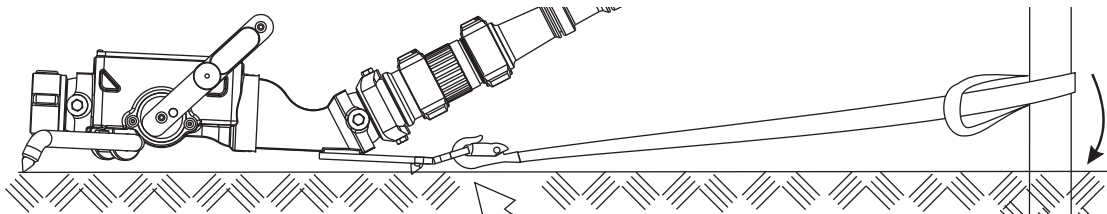

Figure 7.4

WARNING

Personnel in the path of an out of control monitor have and increase risk of injury or death. Securely tying the monitor off to an immovable object can limit the monitor travel in the event of an out of control monitor. Always tie off the monitor when it is in use. Remove all slack between the anchor and monitor before flowing water.

8.0 OSC OSCILLATING UNIT

An automatic oscillating mechanism is available for the BLITZFIRE Monitor. The BLITZFIRE Monitor can be purchased with the oscillating mechanism factory installed or added at the factory later.

8.1 SAFETY - OSCILLATOR

⚠ DANGER

Modifying this oscillating mechanism to fit any other monitor will cause the reaction force of the nozzle to be unaligned with the center of rotation. An unaligned monitor may spin very fast with a very high force, which can result in serious injury or death. Do not modify the oscillator to fit any other monitor.

⚠ WARNING

When the oscillator is in operation, the reaction force is acting in different directions on the leg spikes. These sudden changes in direction may cause the monitor to become off-balance resulting in sliding or loss of control. Make sure the monitor is on a firm surface with adequate holding power and properly anchored by the tie down strap before operating the oscillator.

⚠ CAUTION

The oscillator unit contains moving parts that can pinch fingers and hands when the unit is in operation. Keep hands and fingers away from the moving parts of the oscillating unit when water is flowing.

⚠ CAUTION

Because the nozzle attached to the oscillator must slow down, stop and reverse direction at the end of each sweep, the ends of the covered area will receive more water than the center. If the center area of coverage needs the most cooling, occasionally narrow the area of coverage or use the oscillator manually.

8.2 GENERAL - OSCILLATOR

The BLITZFIRE oscillating mechanism can be used for exposure protection, cooling, or any other situation where it is desirable to have a monitor sweep back and forth.

The oscillating mechanism is driven by a turbine wheel. A worm gear drive reduces the speed and increases the torque of the turbine wheel. A simple crank mechanism makes the outlet of the BLITZFIRE and the nozzle attached to it move back and forth. The horizontal sweep can be set for 20, 30, and 40 degree coverage. The oscillating mechanism can be uncoupled and the water stream can be aimed manually.

The speed of oscillation is a function of flow rate, see the BLITZFIRE Oscillation Speed graph. A minimum flow rate of 175 gpm is required for proper oscillator operation.

8.3 OPERATION - OSCILLATOR

The BLITZFIRE oscillator is protected by a shock absorber system. If the nozzle encounters an obstruction, the shock absorber will compress or extend as needed to protect the gears from overload.

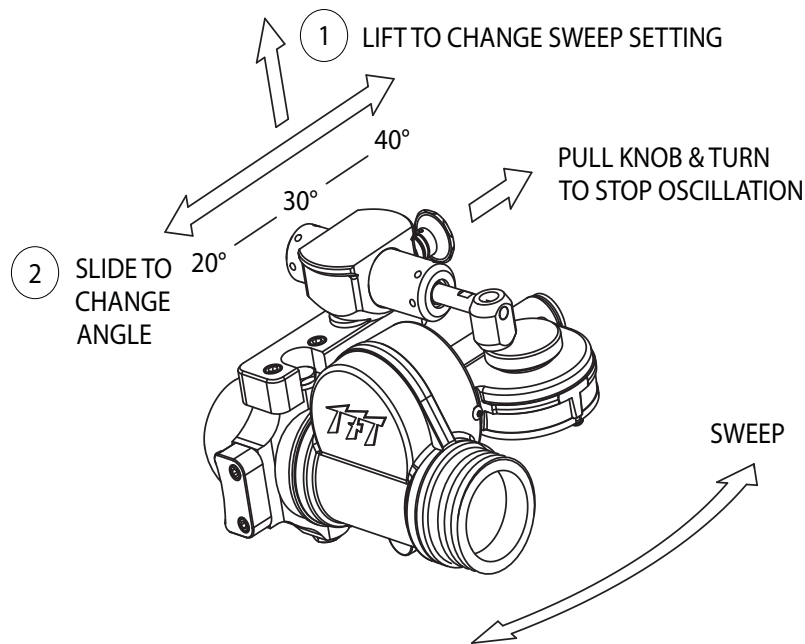

Figure 8.3

8.4 OSCILLATION SPEED AND COVERAGE

Oscillation Speed: The chart shows how many times per minute the oscillator makes one complete cycle as a function of flow. The higher the flow, the faster it oscillates. A minimum flow rate of 175 GPM is required for proper oscillator operation.

Nozzle Reach: Refer to the operation manual for the specific nozzle. For reach with oscillation, subtract 20% from the distance.

APPROXIMATE CYCLES/MIN	GPM	L/MIN
8	175	650
13	250	1000
21	375	1500
28	500	2000

Blitzfire OSCILLATION SPEED

Table 8.4

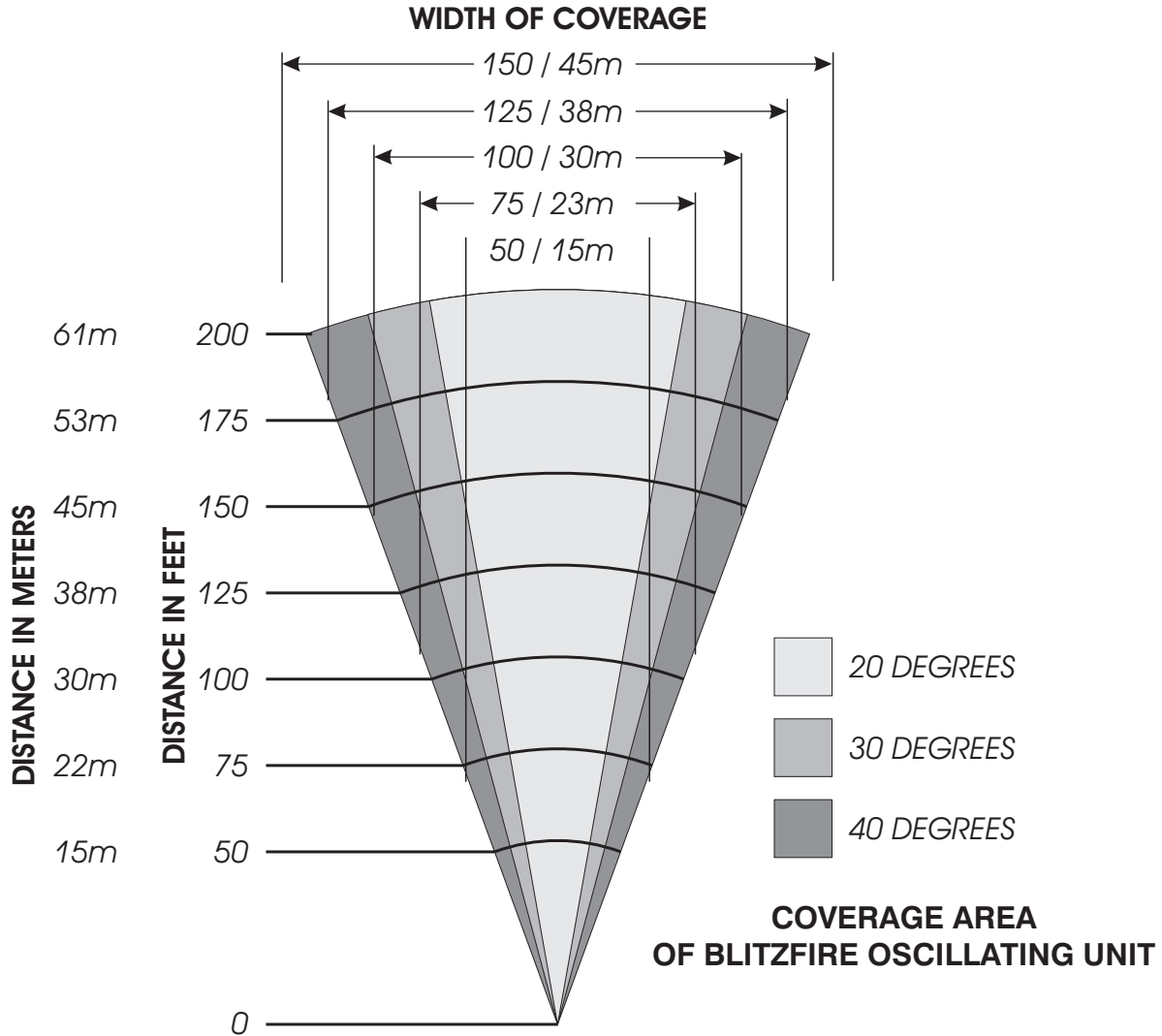

Figure 8.4

NOTICE

The type of nozzle and flow pressure are critical to the coverage area. The graph shows coverage area based on the movement capability of the oscillating mechanism. Actual coverage will depend on flow, pressure, type of nozzle, angle of fog pattern, and wind conditions.

9.0 STORAGE

The monitor may be stored pre-connected to its hose on the optional storage bracket, TFT part number XX-B. The storage bracket may be mounted on a horizontal surface, or a vertical surface with the nozzle end pointing down or sideways.

To mount the bracket, follow the instructions (LIX-635) provided with the bracket kit.

WARNING

The Portable Monitor Storage Bracket is designed only to store the Portable Monitor. Attempting to flow from the storage bracket can cause the monitor to become dislodged from the bracket and out of control, causing severe injury or death. Always properly deploy the monitor before flowing.

10.0 WARRANTY

Task Force Tips LLC, 3701 Innovation Way, Valparaiso, Indiana 46383-9327 USA ("TFT") warrants to the original purchaser of its products ("equipment"), and to anyone to whom it is transferred, that the equipment shall be free from defects in material and workmanship during the five (5) year period from the date of purchase for mechanical components, and the two (2) year period from the date of purchase for electrical components. TFT's obligation under this warranty is specifically limited to replacing or repairing the equipment (or its parts) which are shown by TFT's examination to be in a defective condition attributable to TFT. To qualify for this limited warranty, the claimant must return the equipment to TFT, at 3701 Innovation Way, Valparaiso, Indiana 46383-9327 USA, within a reasonable time after discovery of the defect. TFT will examine the equipment. If TFT determines that there is a defect attributable to it, TFT will correct the problem within a reasonable time. If the equipment is covered by this limited warranty, TFT will assume the expenses of repair.

If any defect attributable to TFT under this limited warranty cannot be reasonably cured by repair or replacement, TFT may elect to refund the purchase price of the equipment, less reasonable depreciation, in complete discharge of its obligations under this limited warranty. If TFT makes this election, claimant shall return the equipment to TFT free and clear of any liens and encumbrances.

This is a limited warranty. The original purchaser of the equipment, any person to whom it is transferred, and any person who is an intended or unintended beneficiary of the equipment, shall not be entitled to recover from TFT any consequential or incidental damages for injury to person and/or property resulting from any defective equipment manufactured or assembled by TFT.

It is agreed and understood that the price stated for the equipment is in part consideration for limiting TFT's liability. Some states do not allow the exclusion or limitation of incidental or consequential damages, so the above may not apply to you.

TFT shall have no obligation under this limited warranty if the equipment is, or has been, misused or neglected (including failure to provide reasonable maintenance) or if there have been accidents to the equipment or if it has been repaired or altered by someone else.

THIS IS A LIMITED EXPRESS WARRANTY ONLY. TFT EXPRESSLY DISCLAIMS WITH RESPECT TO THE EQUIPMENT ALL IMPLIED WARRANTIES OF MERCHANTABILITY AND ALL IMPLIED WARRANTIES OF FITNESS FOR A PARTICULAR PURPOSE. THERE IS NO WARRANTY OF ANY NATURE MADE BY TFT BEYOND THAT STATED IN THIS DOCUMENT.

This limited warranty gives you specific legal rights, and you may also have other rights which vary from state to state.

11.0 MAINTENANCE

TFT products are designed and manufactured to be damage resistant and require minimal maintenance. However, as the primary firefighting tool upon which your life depends, it should be treated accordingly. The unit should be kept clean and free of dirt by rinsing with water after each use. Any inoperable or damaged parts should be repaired or replaced before placing the unit in service. To help prevent mechanical damage, do not drop or throw equipment.

In applications where appliances are left continuously connected to the apparatus or other devices or are used where water is trapped inside the appliance, the appliance must be flushed with fresh water following each use and inspected for damage.

This appliance should be disconnected, cleaned and visually inspected inside and out at least quarterly, or as water quality and use may require. Moving parts such as handles, valve ball and couplings should be checked for smooth and free operation. Seals shall be greased as needed with Silicone based grease such as Molykote 112. Any scrapes that expose bare aluminum should be cleaned and touched up with enamel paint such as Rust-Oleum. Replace any missing or damaged parts before returning to service.

Any equipment taken out of service due to failure should be returned to the factory for repair or replacement. If you have any questions regarding the testing or maintenance of your valve, please call Task Force Tips at 800-348-2686.

11.1 SERVICE TESTING

In accordance with NFPA 1962, equipment must be tested a minimum of annually. Units failing any part of this test must be removed from service, repaired and retested upon completion of the repair.

11.2 REPAIR

Factory service is available. Factory serviced equipment is repaired by experienced technicians, wet tested to original specifications, and promptly returned. Call TFT service department at 1-800-348-2686 to troubleshoot and, if needed, directions for return. A return for service form can also be obtained at tft.com/Support/Returning-an-Item-for-Service.

Repair parts and service procedures are available for those wishing to perform their own repairs. Task Force Tips assumes no liability for damage to equipment or injury to personnel that is a result of user service. Contact the factory or visit the web site at tft.com for parts lists, exploded views, test procedures and troubleshooting guides.

Performance tests shall be conducted on the equipment after a repair, or anytime a problem is reported to verify operation in accordance with TFT test procedures. Consult factory for the procedure that corresponds to the model and serial number of the equipment. Any equipment which fails the related test criteria should be removed from service immediately. Troubleshooting guides are available with each test procedure or equipment can be returned to the factory for service and testing.



It is the responsibility of service technicians to ensure the use of appropriate protective clothing and equipment. The chosen protective clothing and equipment must provide protection from potential hazards users may encounter while servicing equipment. Requirements for protective clothing and equipment are determined by the Authority Having Jurisdiction (AHJ).



Any alterations to the product or its markings could diminish safety and constitutes a misuse of this product.



All replacement parts must be obtained from the manufacturer to assure proper performance and operation of the device.

12.0 EXPLODED VIEW AND PARTS LISTS

Exploded views and parts lists are available at tft.com/serial-number.

This page intentionally left blank.

13.0 OPERATION AND INSPECTION CHECKLIST

BEFORE BEING PLACED BACK IN SERVICE, appliances must be inspected to this list:

1. All valves open and close smoothly and fully.
2. The waterway is clear of obstructions.
3. There is no damage to any thread or other type of connection.
4. All locks and hold-down devices are in proper working order.
5. Internal gaskets are in good repair in accordance with NFPA 1962.
6. There is no damage to the appliance (dents, cracks, corrosion, or other defects that could impair operation).
7. All swiveling connections rotate freely.
8. There are no missing parts or components.
9. The marking of maximum operating pressure is visible.
10. There are no missing, broken, or worn lugs on couplings.

BEFORE EACH USE, appliances must be inspected to this list:

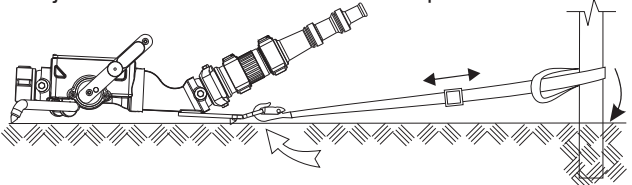
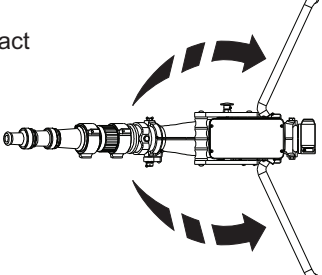
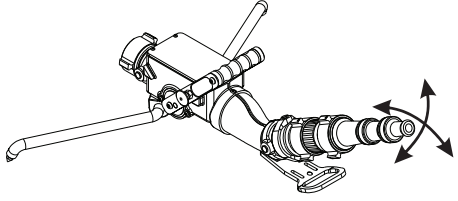
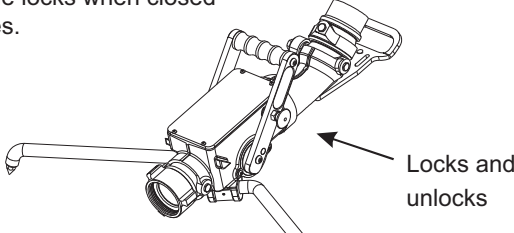
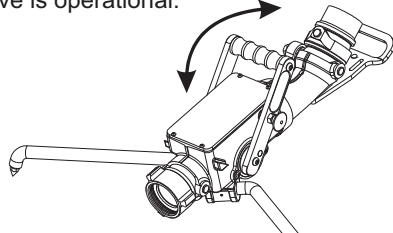
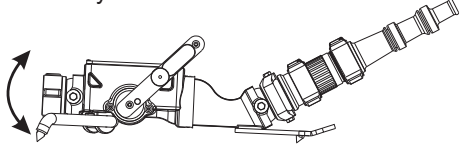
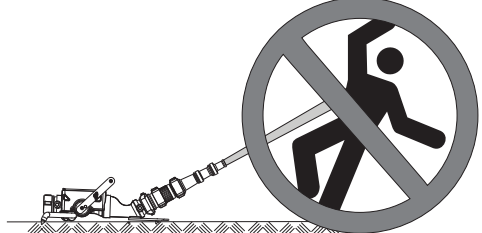
<p>1) There is no damage to the appliance that could impair safe operation (e.g. dents, cracks, corrosion, missing, broken or loose parts, damaged markings, or other defects).</p> <ul style="list-style-type: none"> • Waterway is clear of obstructions. • Gaskets are in good repair. • Hose and nozzle are securely attached. • The pressure setting on the relief valve (if so equipped) is set correctly. <p>2) Hose and nozzle are securely attached.</p>	<p>7) Monitor is anchored and securely tied off to an immovable object with no slack in the anchor strap.</p>  <p>• Tied off (REQUIRED) • Hooked leg • Spike hold • Weight</p>
<p>3) Both legs are fully open. 4) All three spikes are in contact with the ground.</p> 	<p>8) Outlet pivots smoothly in both directions.</p> 
<p>5) Valve handle locks when closed and releases.</p>  <p>Locks and unlocks</p>	<p>9) Shut-Off valve is operational.</p> 
<p>6) Inlet pivots freely.</p> 	<p>10) Monitor is pointed in a safe direction.</p> 

WARNING

Equipment failing any part of the checklist is unsafe for use and must have the problem corrected before use or being placed back into service. Operating equipment that has failed the checklist is a misuse of this equipment.

TASK FORCE TIPS LLC
MADE IN USA · tft.com

3701 Innovation Way, Valparaiso, IN 46383-9327 USA
800-348-2686 · 219-462-6161 · Fax 219-464-7155