



MANUAL: BLITZFIRE® Portable Monitor Series

INSTRUCTIONS FOR SAFE OPERATION AND MAINTENANCE

⚠ DANGER

Understand manual before use. Operation of this device without understanding the manual and receiving proper training is a misuse of this equipment. Obtain safety information at www.tft.com/serial-number.

⚠ DANGER

Risk of sliding increases at low elevation angles. To reduce risk of injury or death from sliding, test safety shutoff before using.

This Instruction Manual is intended to familiarize firefighters and maintenance personnel with the operation, servicing, and safety procedures associated with the portable monitor.

This manual should be kept available to all operating and maintenance personnel.

Maximum Pressure at no flow:
300 PSI (20 bar)

Maximum Operating Condition:
175 PSI (12 bar) @ 500 GPM (2000 l/min)

Hydrostatic Proof Test:
900 PSI (62 bar) per NFPA 1965

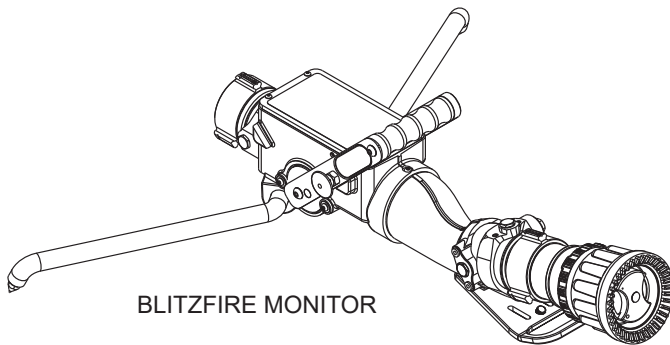

BLITZFIRE MONITOR

blitzfire®

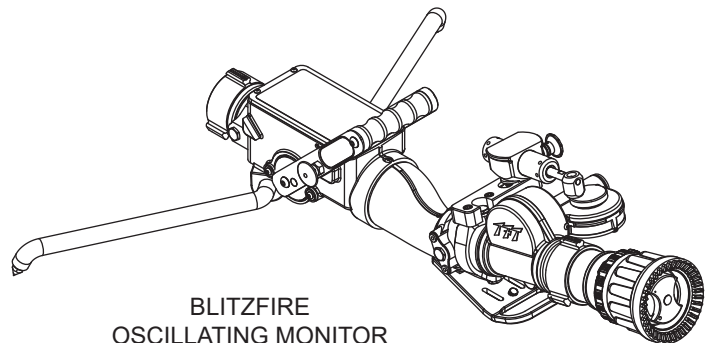

BLITZFIRE
OSCILLATING MONITOR

blitzfire® osc

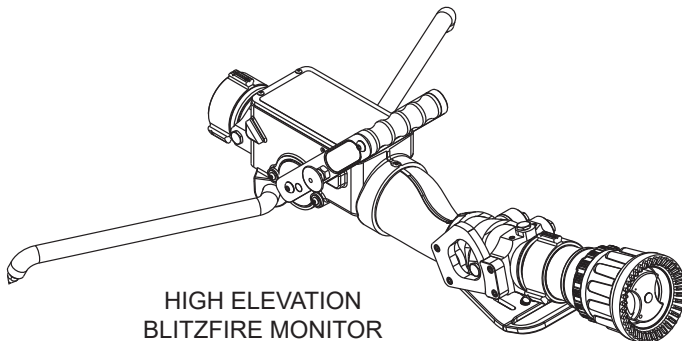

HIGH ELEVATION
BLITZFIRE MONITOR

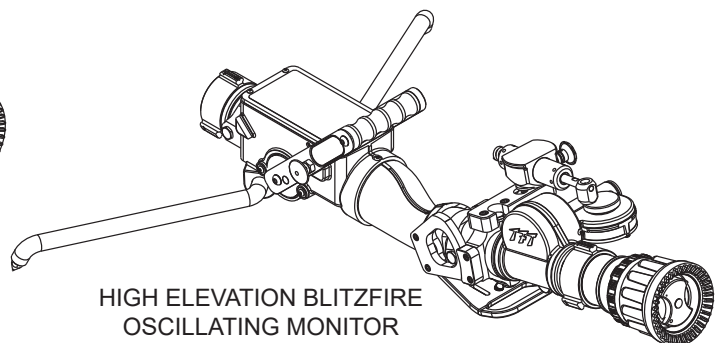

HIGH ELEVATION BLITZFIRE
OSCILLATING MONITOR

TASK FORCE TIPS, INC.
MADE IN USA • www.tft.com

3701 Innovation Way, Valparaiso, IN 46383-9327 USA
800-348-2686 • 219-462-6161 • Fax 219-464-7155

Table Of Contents

1.0 MEANING OF SAFETY SIGNAL WORDS	10.0 DRAWINGS AND PART LISTS
2.0 SAFETY	10.1 SAFETY MECHANISM ASSEMBLY VIEW
3.0 GENERAL INFORMATION	10.2 BLITZFIRE MONITOR EXPLODED VIEW
3.1 VARIOUS MODELS AND TERMS	10.2.1 BLITZFIRE MONITOR PARTS LIST
3.2 SPECIFICATIONS	10.3 STANDARD BLITZFIRE OUTLET EXPLODED VIEW
3.2.1 MECHANICAL	10.3.1 STANDARD BLITZFIRE OUTLET PARTS LIST
3.2.2 OPERATING ENVELOPE	10.4 HIGH ELEVATION BLITZFIRE OUTLET EXPLODED VIEW
3.3 FLOW CONTROL VALVE OPERATION	10.4.1 HIGH ELEVATION BLITZFIRE OUTLET PARTS LIST
3.3.1 UNLOCKING THE VALVE HANDLE FROM THE CLOSED POSITION	10.5 OSCILLATING EXPLODED VIEW
3.3.2 SAFETY SHUT-OFF VALVE OPERATION	10.5.1 OSCILLATING PARTS LIST
3.3.3 SAFETY SHUT-OFF VALVE TEST	11.0 WARRANTY
3.3.4 MANUAL OVERRIDE OF SAFETY SHUT-OFF VALVE	12.0 MAINTENANCE
3.3.5 SLOW CLOSE VALVE FEATURE	12.1 SERVICE TESTING
3.4 FOLDING LEGS	12.1.1 HYDRAULIC TEST
3.4.1 CARBIDE SPIKES	12.1.2 SHUTOFF VALVE TEST
3.5 PIVOTING INLET	12.1.3 RECORDS
3.6 OUTLET PIVOTS	12.2 REPAIR
3.6.1 ELEVATION HOLDING MECHANISM	13.0 ANSWERS TO YOUR QUESTIONS
3.7 COUPLINGS	14.0 OPERATION and INSPECTION CHECKLIST
3.8 USE WITH SALT WATER	
4.0 FLOW CHARACTERISTICS	
4.1 AUTOMATIC, FIXED AND SELECTABLE FLOW NOZZLES	
4.2 STACKED TIPS OR SMOOTHBORE NOZZLES	
4.3 STREAM STRAIGHTENERS	
4.4 USE WITH FOAM	
4.5 PRESSURE LOSS	
5.0 OPERATION	
5.1 DEPLOYMENT	
5.2 CARRYING WITH AN UNCHARGED HOSE	
5.3 ADVANCING WITH A CHARGED HOSE	
6.0 ANCHORING	
6.1.1 ANCHORING BY WEIGHT	
6.1.2 ANCHORING BY SPIKE HOLDS	
6.1.3 ANCHORING BY HOOKING LEGS	
6.1.4 ANCHORING BY TYING OFF WITH SAFETY STRAP	
7.0 OSCILLATION UNIT GENERAL INFORMATION	
7.1 SAFETY – OSCILLATOR	
7.2 VARIOUS MODELS AND TERMS – OSCILLATOR	
7.3 OPERATION – OSCILLATOR	
7.4 OSCILLATING SPEED AND COVERAGE	
8.0 APPROVALS	
9.0 STORAGE	



PERSONAL RESPONSIBILITY CODE

The member companies of FEMSA that provide emergency response equipment and services want responders to know and understand the following:





1. Firefighting and Emergency Response are inherently dangerous activities requiring proper training in their hazards and the use of extreme caution at all times.
2. It is your responsibility to read and understand any user's instructions, including purpose and limitations, provided with any piece of equipment you may be called upon to use.
3. It is your responsibility to know that you have been properly trained in Firefighting and /or Emergency Response and in the use, precautions, and care of any equipment you may be called upon to use.
4. It is your responsibility to be in proper physical condition and to maintain the personal skill level required to operate any equipment you may be called upon to use.
5. It is your responsibility to know that your equipment is in operable condition and has been maintained in accordance with the manufacturer's instructions.
6. Failure to follow these guidelines may result in death, burns or other severe injury.











Fire and Emergency Manufacturers and Service Association
P.O. Box 147, Lynnfield, MA 01940 • www.FEMSA.org

1.0 MEANING OF SAFETY SIGNAL WORDS

A safety related message is identified by a safety alert symbol and a signal word to indicate the level of risk involved with a particular hazard. Per ANSI standard Z535.6-2011, the definitions of the four signal words are as follows:

	DANGER indicates a hazardous situation which, if not avoided, will result in death or serious injury.
	WARNING indicates a hazardous situation which, if not avoided, could result in death or serious injury.
	CAUTION indicates a potentially hazardous situation which, if not avoided, could result in minor or moderate injury.
	NOTICE is used to address practices not related to physical injury.

2.0 SAFETY

	An inadequate supply of nozzle pressure and/or flow will cause an ineffective stream and can result in injury, death, or loss of property. See flow graphs in section 3.0 or call 800-348-2686 for assistance.
	This equipment is intended for use by trained personnel for firefighting. Their use for other purposes may involve hazards not addressed by this manual. Seek appropriate guidance and training to reduce risk of injury.
	An out of control monitor can cause injury or death. To reduce the risk of instability, do not attempt to move the monitor with water flowing.
	The flow from the monitor may be vital to keep a firefighter from injury or death. Avoid situations that may interrupt flow to the monitor such as: hose line kinks, traffic running over hose, and automatic doors or devices that can pinch the hose.
	The monitor may be damaged if frozen while containing sufficient amounts of water. Such damage may be difficult to detect visually and can lead to possible injury or death. Any time the monitor is subject to possible damage from freezing, it must be hydrostatically tested by qualified personnel before being considered safe for use.
	Master streams are powerful and capable of causing injury and property damage. Make sure the monitor is pointing in a safe direction before water to the nozzle is turned on. Use care in directing the stream.
	Monitor must be properly connected to a hose and nozzle with matched threads. Mismatched or damaged threads may cause leaking or uncoupling under pressure and could cause injury.
	Dissimilar metals coupled together can cause galvanic corrosion that can result in the inability to unscrew the threads or complete loss of thread engagement over time. Per NFPA 1962, if dissimilar metals are left coupled together an anti-corrosive lubricant should be applied to the threads. Also the coupling should be disconnected and inspected at least quarterly.
	To prevent mechanical damage, do not drop or throw equipment.

3.0 GENERAL INFORMATION

The Blitzfire is a simple, light and easy to maneuver portable monitor. The monitor has a revolutionary safety shut-off valve, which will shut-off the water flow in the event of sudden movement by the monitor. This safety feature reduces the risk of injury from an out of control master stream device. General product specifications are as follows:

- Standard Inlet Coupling: 2 ½ inch NH Female
- Standard Outlet: 2 ½ inch NH male
- Flow range: up to 500 GPM (2000 LPM)
- Vertical Stream Range: 10 to 46 or 86 degrees above horizontal
- Horizontal Stream Range: +/- 20 degrees either side of centerline

3.1 VARIOUS MODELS AND TERMS

The Blitzfire Portable Monitor is an efficient, compact and easy to maneuver portable monitor. This monitor can be mounted in a pre-connected state on the truck-mounting storage bracket for achieving quick and effective initial attack.

The Blitzfire monitor is available in standard and high elevation models. Figure 3.1 identifies the various parts and controls on a standard Blitzfire portable monitor. Parts and controls for a high elevation model are similar.

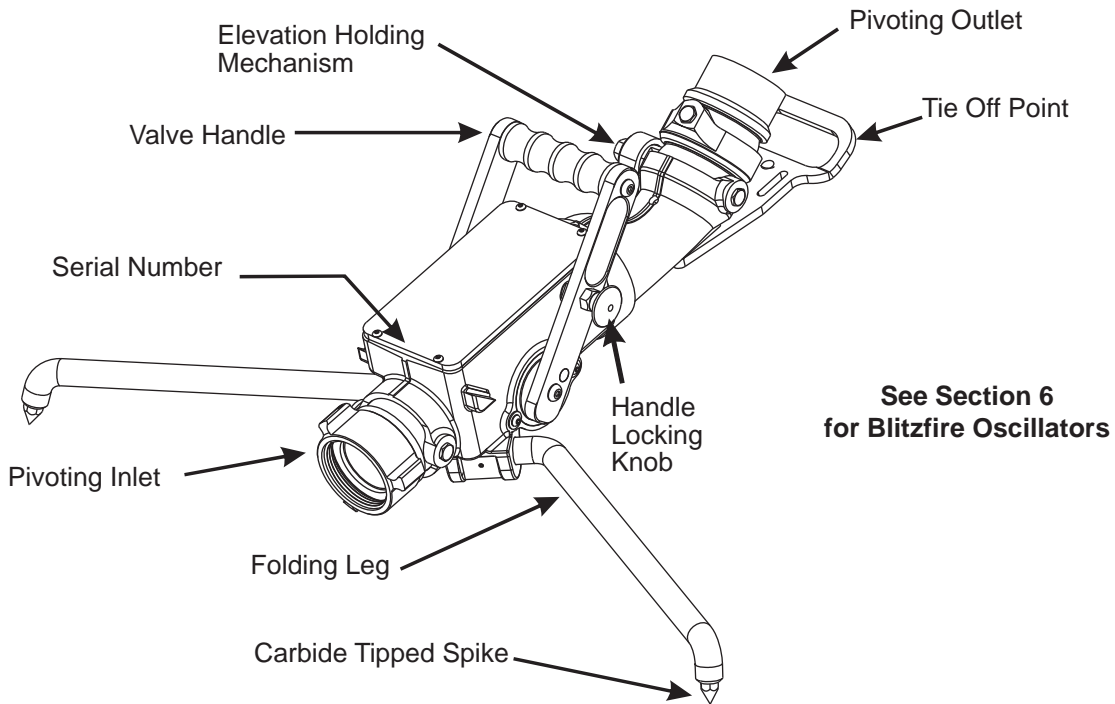

Figure 3.1 Parts and Controls

3.2 SPECIFICATIONS

3.2.1 MECHANICAL

Maximum inlet pressure with valve shut off	300 PSI (20 bar)
Operating temperature range of dampening fluid	33°F - 120°F (1°C - 50°C)
Materials used	Aluminum 6000 series hard anodized MIL8625 class 3 type 2, stainless steel 300 series, nylon 6-6, nitrile rubber

3.2.2 OPERATING ENVELOPE

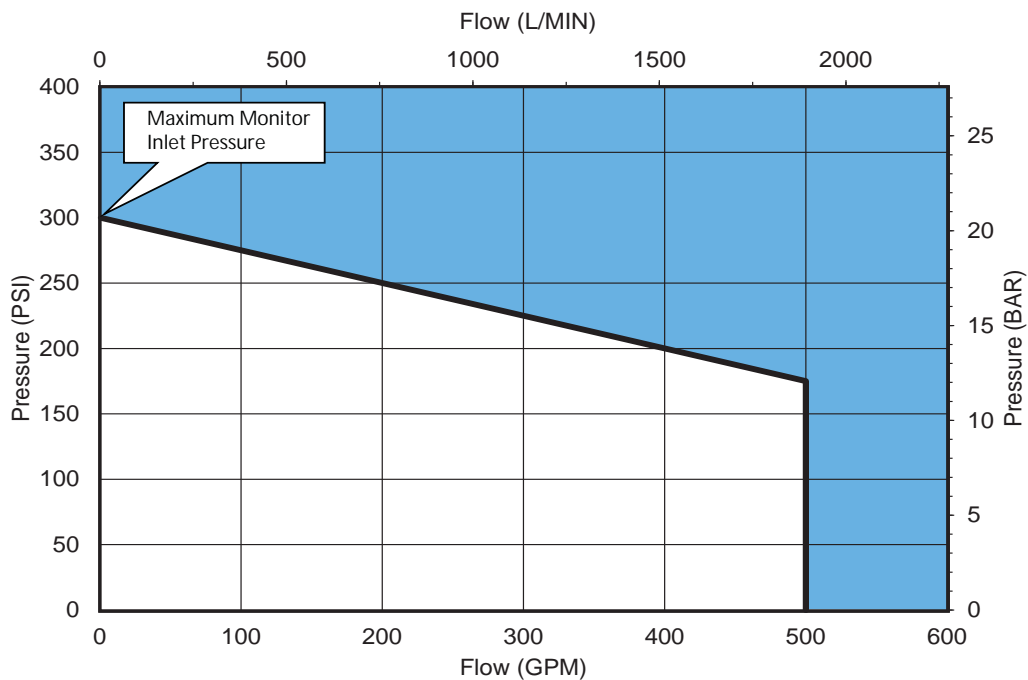

3.3 FLOW CONTROL VALVE OPERATION

The Blitzfire has a valve that can be used to control the flow and acts as a safety shut-off feature. The valve is shut-off when the valve handle is fully forward. The valve is fully on when the valve handle is fully back. The valve can be opened to any of six detented flow positions. These detented positions allow the monitor operator to regulate the flow depending on the need or what can be safely and effectively handled.

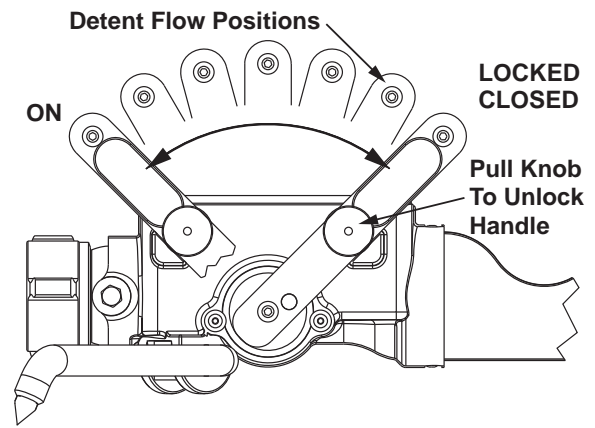

Figure 3.3 Valve Handle Positions

3.3.1 UNLOCKING THE VALVE HANDLE FROM THE CLOSED POSITION

The valve handle is locked in the closed position so that the valve handle may be used to carry the Blitzfire without the valve inadvertently opening. To unlock the valve handle from the closed position:

1. Pull knob on right side of the valve handle.
2. While pulling on knob, open the valve with the other hand.

As soon as valve is opened the knob may be released. The valve handle may be moved to any detent valve position by pushing or pulling on the valve handle. When the valve is closed the valve handle automatically locks and must be unlocked again to reopen. The valve opening procedure is shown in figure 3.3.1.

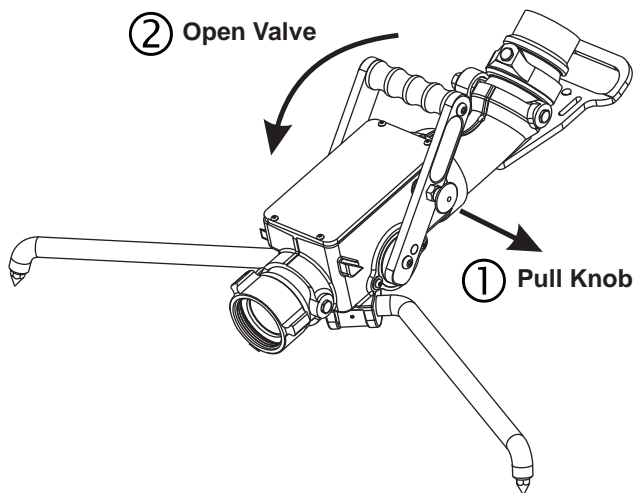
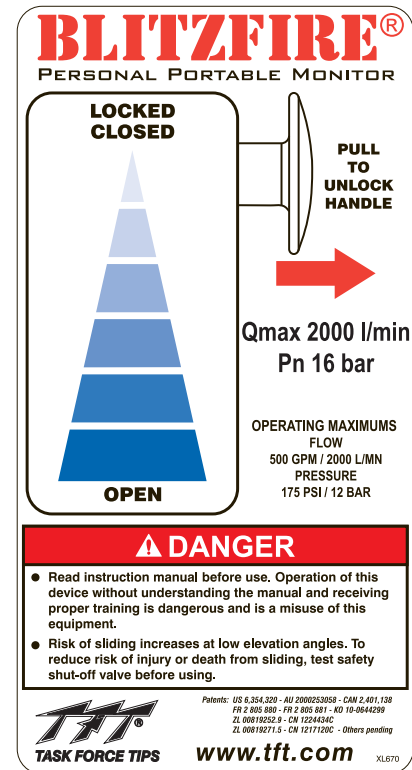

Figure 3.3.1 Valve Opening Procedure



⚠️ WARNING

Quick changes in valve position can cause high pressure spikes due to water hammer and may result in damaged equipment which could lead to injury or death. Open and close the valve slowly to avoid water hammer.

⚠️ WARNING

Injury or death may occur by attempting to use a damaged valve. The device shall be inspected and tested at least quarterly. Before using the monitor inspect it for damage resulting from:

- Failure to drain followed by exposure to freezing conditions
- Exposure of monitor to temperatures in excess of 160 degrees F
- Missing parts
- Physical abuse

⚠️ WARNING

Injury or death from an out of control monitor can occur. If monitor gets out of control, retreat from monitor immediately. Do not attempt to regain control of monitor while it is flowing.

To minimize the risk of an out of control monitor:

- Test Shut-off Valve before each use.
- Tie off the monitor when practical.
- Hook legs on stationary objects such as door frames, cracks, sign posts etc.
- Keep elevation as high as practical.
- Choose surfaces that allow spikes to dig in.
- Assure that the hose is not lifting the spikes off the ground.
- Reduce flow to limit nozzle reaction if stability is questionable

3.3.2 SAFETY SHUT-OFF VALVE OPERATION

The Blitzfire is equipped with a Safety Shut-Off Valve. The Safety Shut-Off Valve will shut off the monitor's flow if the monitor starts to move. The Safety Shut-Off Valve relies on acceleration of the Blitzfire as the signal to activate. It activates at approximately one G of sideways acceleration. Placing the Blitzfire on tilted surfaces (greater than 10 degrees) may inhibit the resetting of the Safety Shut-Off Valve. The hose connected to the Blitzfire should contain any forward or backwards motion to safe levels.

NOTICE

To make the Blitzfire not shut off completely, see the card titled "Instructions to Maintain Minimal Water Flow When the Safety Shut-off Activates". (LIX-640)

Safety shut-off valve operation:

1. Set up monitor and charge the hose.
2. Point the nozzle in the desired direction.
3. Open the valve by pulling the locking pin and pulling back on the valve handle (see section 3.3.1)
4. Place the valve handle in the desired detent position (further back for more flow, further forward for less).
5. If the monitor starts to slide, the safety valve will sense the movement and release the valve.
 - An internal spring and water pressure will move the valve forward to the closed position and shut off the water flow.
 - The valve handle will lock in the closed position.
6. The safety shut-off valve will automatically reset.
7. After the cause of the sliding has been corrected, reopen the valve as outlined in step 3.

NOTICE

Valve must be fully closed to reset the safety shut-off mechanism. Once tripped the valve handle will not stay open unless the mechanism is reset by fully closing the valve.

If the safety shut-off valve fails to reset, the valve will not remain open. Failure to reset may be due to placing the monitor on an excessively sloped surface.

WARNING

The safety shut-off valve is only sensitive to sideways acceleration of the monitor. Keep the hose directly behind the monitor to reduce potential acceleration in the forward and backward direction. Do not loop hose in front of monitor.

WARNING

The safety shut-off valve needs approximately one G of sideways acceleration to activate. At low accelerations the monitor may travel several yards (meters) and gain enough velocity to cause injury before the safety shut-off valve activates. Personnel several feet away and in the potential path of a sliding monitor are at risk of injury. Keep non-operating personnel out of the potential path of a sliding monitor.

WARNING

Improper repairs may result in a malfunctioning safety shut-off valve. If repair is needed on the safety shut-off valve, return the monitor to Task Force Tips.

3.3.3 SAFETY SHUT-OFF VALVE TEST

WARNING

To avoid injury or death, test safety shut-off valve before each use.

With hose uncharged and Blitzfire on a level surface:

1. Open the Valve Handle to the fully open position.
2. Grasp the monitor and give it a sideways jerk, rotate to trip the valve or hit on the side with a rubber mallet.
3. The Valve Handle should move to the closed position.

Note: With water flowing the valve has additional forces on it that will close the valve the rest of the way.

If the Safety Shut-Off Valve fails the test, return the monitor to Task Force Tips to restore proper functioning of the safety shut-off valve. If the monitor is used before repair, the user accepts the risk of an out of control monitor.

WARNING

The safety shut-off valve is intended to shut off the monitor when it moves. It will not prevent it from moving. The device shall limit the motion and injury that may occur once the monitor starts to move. Use adequate means to secure the monitor to prevent injury.

3.3.4 MANUAL OVERRIDE OF SAFETY SHUT-OFF VALVE

On sloping terrain it may be necessary to manually override the Safety Shut-Off Valve. The Safety Shut-Off Valve can be overridden by holding the valve handle in an open position.

⚠ WARNING Do not tie or prop open the valve handle. Tampering with the valve handle will render the Safety Shut-Off inoperable and may result in injury or death.

3.3.5 SLOW CLOSE VALVE FEATURE

The Blitzfire has a valve damping mechanism to slow valve closure as it approaches OFF to reduce the effects of water hammer. The damping mechanism has a vane moving in dampening fluid connected to the valve handle on the left side of the monitor.

⚠ WARNING Do not add or change dampening fluid. Improper servicing may result in a malfunctioning safety shut-off valve. If service is needed on the slow close device, contact Task Force Tips service department at 800-348-2686.

⚠ WARNING “Water Hammer” is present any time a valve is closed when water is flowing. The effects of water hammer can be made worse with short hose lines, small hose lines, and high flows. All personnel operating in the vicinity of charged hose lines should be especially cautious around any hose that is providing high flows that might be shut off quickly in an emergency. The dampening device in the Blitzfire monitor reduces the effects of water hammer but DOES NOT ELIMINATE IT!

3.4 FOLDING LEGS

The Blitzfire has two legs that fold for storage and unfold for operation. The legs are held in the folded and unfolded position by spring detents. To fold or unfold the legs:

1. Grasp the spike end of one leg and pivot it to the folded or unfolded position.
2. Repeat for the other leg.

⚠ WARNING In the unfolded position the legs provide a stable base for operation of the monitor. Lack of stability can cause an out of control monitor resulting in injury or death. Do not operate as a portable monitor with either one or both legs in the folded position.

3.4.1 CARBIDE SPIKES

The Blitzfire monitor has 3 tungsten carbide tipped spikes on the legs and the base to resist sliding by digging into the surface the monitor is sitting on. The amount of sliding force these spikes can withstand depends upon the amount of downward and sideways force that is on the monitor and the hardness and texture of the surface the spikes are in contact with. At low elevation angles it is difficult for these spikes to resist sliding. These spikes are essential to safe operation of the monitor and must be in contact with the ground at all times. Set the monitor on an even surface so that all three spikes contact the ground. Replace any spike if the tip diameter exceeds 1/16 inch (1.6 mm). Order replacement spike kit: XX482-KIT.

⚠ WARNING For stable operation the three spikes must maintain in contact with the ground. Do not place the Blitzfire on top of debris, objects, or uneven terrain that would keep any of the spikes from contacting the ground.

⚠ WARNING On hard slippery surfaces the spikes may provide little resistance to sliding. In these cases the monitor should be tied off or the legs hooked on stationary objects to keep the monitor in position. Also, a person’s weight applied to the monitor may help increase resistance to sliding.

⚠ CAUTION Spikes must be sharp to provide resistance to sliding. Replace any spike if the tip diameter exceeds 1/16 inch (1.6 mm).

⚠ CAUTION Spikes are sharp and exposed. Use care around spikes to avoid injury and damage to clothing or other property.

3.5 PIVOTING INLET

The Blitzfire has a pivoting inlet so that different size hoses can be used without lifting the spikes off the ground. The pivoting inlet also allows the monitor to be positioned on porches, stair landings, and the like. The pivot moves up and down 20 degrees. The Blitzfire is equipped with three spikes to provide traction when flowing from the ground. For the spikes to provide traction they must remain in contact with the ground. Assure that the hose is not on top of anything that would cause the spikes to lift off the ground. Figure 3.6a and 3.6b shows the inlet pivot.

3.6 OUTLET PIVOTS

Figure 3.6a and 3.6b shows the outlet pivot travel range. Push or pull on the nozzle to redirect the stream. The pivots are easy to reposition under pressure and are good for rapid redirecting of the stream. However, if the pivot is rapidly bumped against its travel limit, the Safety Shut-Off Valve may activate and shut off the monitor. The Blitzfire has been designed to operate at very low elevation angles to maximize usefulness for interior attack. As with any monitor, when the elevation angle is low the risk of sliding is increased. This is because at low elevation angles the reaction force is more horizontal and less vertical.

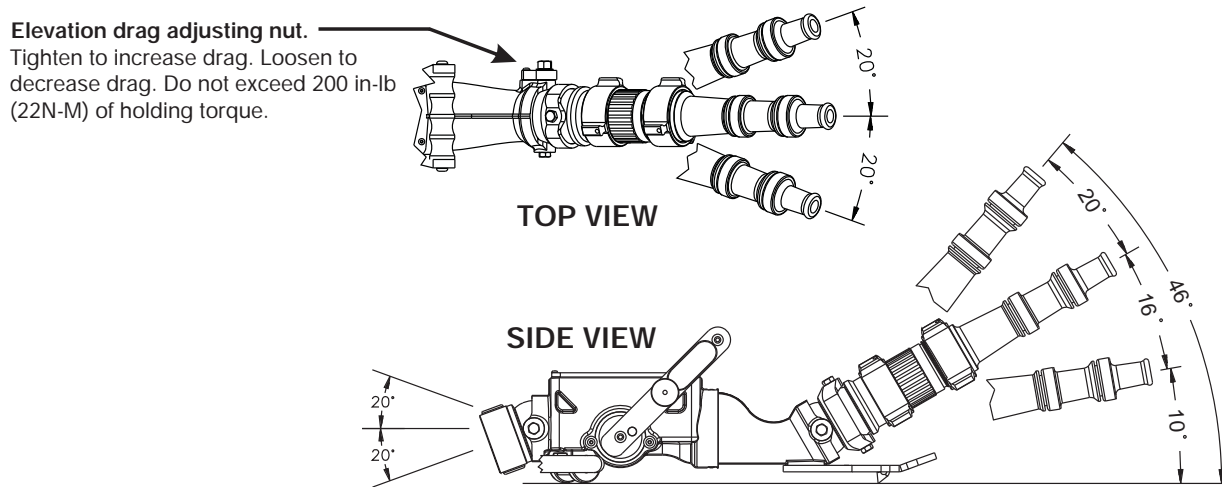

Figure3.6a Blitzfire Travel Range

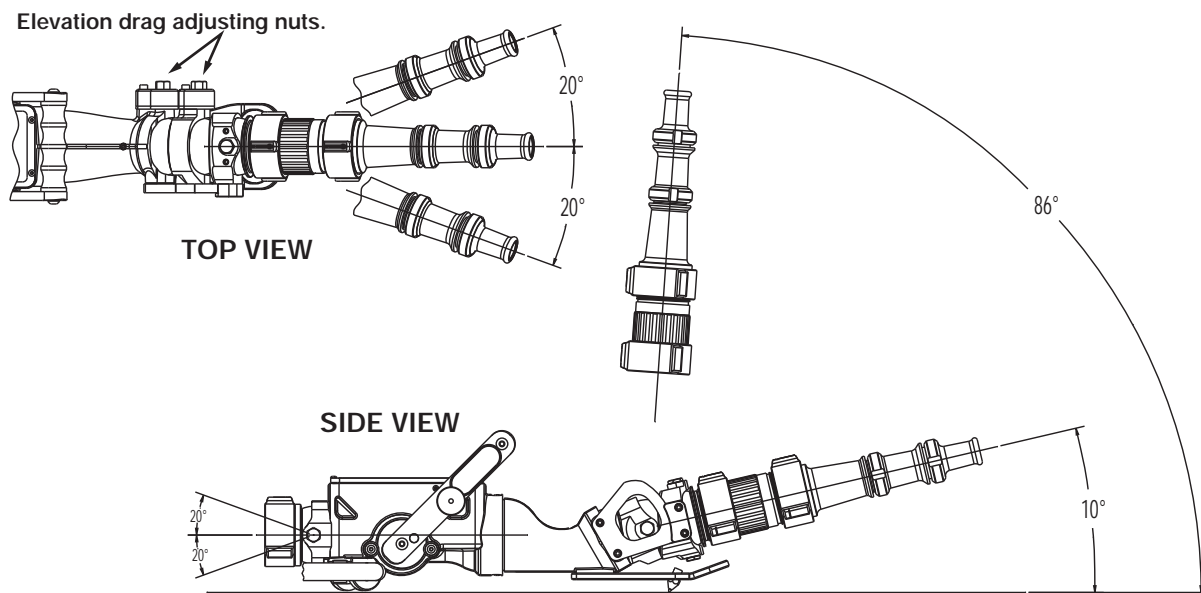

Figure 3.6b Blitzfire High Elevation Travel Range

3.6.1 ELEVATION HOLDING MECHANISM

The elevation pivot has a mechanism to support the weight of a nozzle. It is factory set to support the weight of nozzles likely to be used. It may be adjusted (see figure 3.5a and 3.5b). The mechanism releases when raising the nozzle so upwards drag from the mechanism is not felt. Avoid the use of long stream straighteners or heavy nozzles which may overcome the holding torque of the elevation mechanism.

NOTICE

Only tighten in small increments and only tighten just enough to compensate for the weight of the nozzle (and FoamJet, if applicable). Over tightening of the drag nut will cause damage or premature wear to the elevation holding mechanism.

3.7 COUPLINGS

The Blitzfire Portable Monitor has a full-time swiveling inlet coupling so that when the hose is charged, any twist in the hose will minimize the lifting of the spikes off the ground. The monitor is equipped with three spikes to provide traction when flowing from the ground. For the spikes to provide traction they must remain in contact with the ground. Assure that the hose is not on top of anything that would cause the spikes to be lifted off the ground.

Hose couplings are hard anodized to help prevent corrosion. The effects of corrosion can be minimized by good maintenance practice

3.8 USE WITH SALT WATER

Use with salt water is permissible provided the monitor is thoroughly cleaned with fresh water after each use. The service life of the monitor may be shortened due to the effects of corrosion and is not covered under warranty.

4.0 FLOW CHARACTERISTICS

The Blitzfire Portable Monitor is designed for maximum flows of 500 GPM (2000 LPM) and a maximum pressure of 175 PSI (12 BAR). Do not exceed these limits.

4.1 AUTOMATIC, FIXED, AND SELECTABLE FLOW NOZZLES

A variety of water or foam nozzles may be used with the Blitzfire Portable Monitor. Automatic nozzles maintain a constant pressure by adjusting their opening to match the available flow. Consult the nozzle manufacturer for maximum flow and pressure ratings. In all cases do not exceed 500 GPM (2000 LPM) and/or 175 PSI (12 BAR).

4.2 STACKED TIPS OR SMOOTHBORE NOZZLES

NOZZLE DIAMETER	NOZZLE EXIT PRESSURE									
	50 PSI		80 PSI		100 PSI		150 PSI		175 PSI	
	FLOW (GPM)	REACTION (LBS)	FLOW (GPM)	REACTION (LBS)	FLOW (GPM)	REACTION (LBS)	FLOW (GPM)	REACTION (LBS)	FLOW (GPM)	REACTION (LBS)
1.0 INCH	210	80	266	126	297	157	364	236	390	275
1-1/4 INCH	328	120	415	196	464	245	—	—	—	—
1-1/2 INCH	473	177	—	—	—	—	—	—	—	—

NOZZLE DIAMETER	NOZZLE EXIT PRESSURE									
	4 BAR		6 BAR		8 BAR		10 BAR		12 BAR	
	FLOW (L/min)	REACTION (KG)	FLOW (L/min)	REACTION (KG)	FLOW (L/min)	REACTION (KG)	FLOW (L/min)	REACTION (KG)	FLOW (L/min)	REACTION (KG)
25 MM	830	40	1000	60	1200	80	1300	100	1400	120
32 MM	1300	70	1700	100	1900	130	—	—	—	—
38 MM	1900	90	—	—	—	—	—	—	—	—



FLOW EXCEEDS RATING OF BLITZFIRE PORTABLE MONITOR

4.3 STREAM STRAIGHTENERS

Stream quality, especially with smooth bore nozzles, is generally improved with the use of a stream straightener. A stream straightener is integrated into the exit of the monitor.

4.4 USE WITH FOAM

The Blitzfire may be used with various foam nozzles and foam solutions. Refer to fire service training for the proper use of foam.

⚠ WARNING

Use of compressed air foam (CAF) with portable nozzles can cause sudden surges in nozzle reaction force resulting in injury or death from loss of footing, hose whipping, or an out of control portable monitor. Be prepared for sudden changes in nozzle reaction caused by: Slug loading (Loss of foam concentrate sends slugs of air and water into the nozzle) sudden release of built-up pressure in the hose when opening a nozzle.

4.5 BLITZFIRE PRESSURE LOSS

Figure 4.5 gives the pressure loss for the Blitzfire Portable Monitor

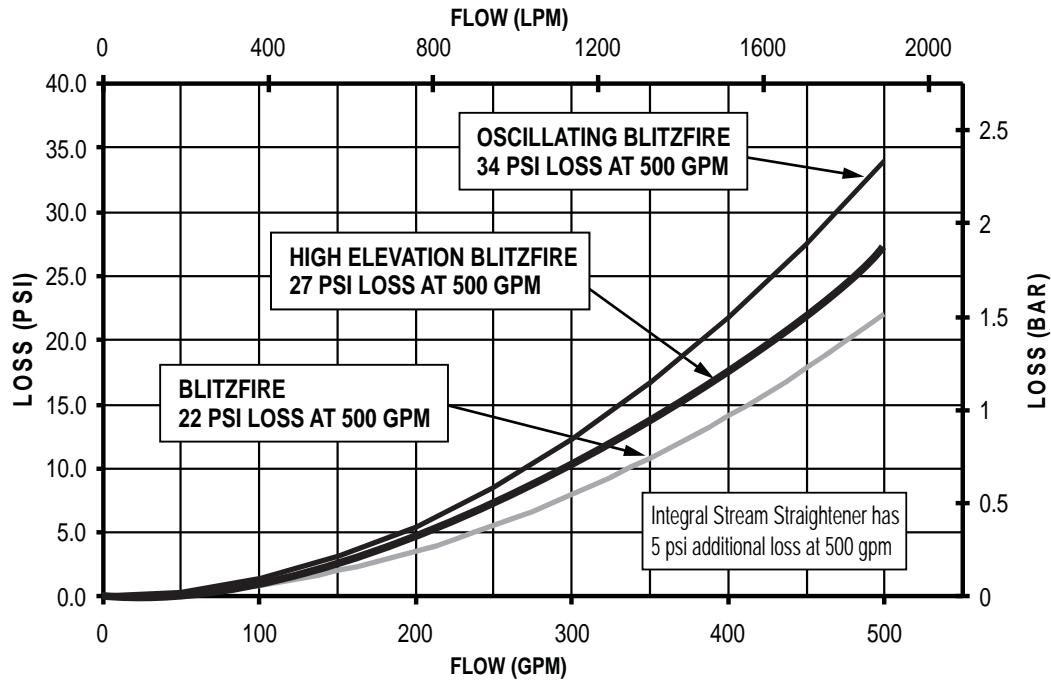

Figure 4.5 Blitzfire Pressure Loss

5.0 OPERATION

5.1 DEPLOYMENT

It is the responsibility of the individual fire department or agency to determine physical capabilities and suitability for an individual's use of this equipment.

5.2 CARRYING WITH AN UNCHARGED HOSE

On a preconnected hoseline the Blitzfire may be carried over the shoulder with the legs folded as illustrated in figure 5.2.



Figure 5.2 Carrying the Blitzfire on an Uncharged Hose

5.3 ADVANCING WITH A CHARGED HOSE

On a charged hose the Blitzfire may be advanced by holding the valve handle and one of the legs as shown in figure 5.3. Valve handle should be locked in the closed position to keep the valve from inadvertently opening.

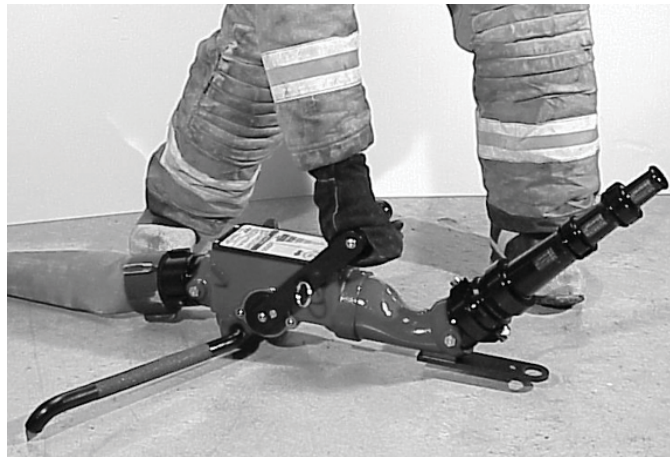

Figure 5.3 Advancing the Blitzfire with a Charged Hose

6.0 ANCHORING

The nozzle reaction force on the Blitzfire Portable Monitor may be as high as 330 lbs - 500 GPM at 175 PSI (150 kg- 2000 LPM at 12 BAR). This nozzle reaction must be restrained to keep the monitor from moving.

The monitor should be anchored from moving by one or more of these methods:

METHOD	RISK of MOVING
Anchoring by Weight	High
Anchoring by Spike Holds	Medium
Hooking legs on vertical surfaces	Medium
Using a tie off strap	Low

6.1.1 ANCHORING BY WEIGHT

On surfaces with good traction a person's weight on the monitor and/or hose may be sufficient to keep the monitor from moving. This is highly dependant on the friction of the surface. The ability to keep one or more than one person's weight on the monitor is subject to operator fatigue and may not be as reliable as other methods. Operating at limited flows will reduce the risk.

6.1.2 ANCHORING BY SPIKE HOLDS

Anchoring by spike holds is defined as intentionally placing one or more spikes into a crack, hole, or other hold to anchor the monitor from moving. On hard smooth surfaces such as ceramic tile, smooth concrete, marble, terrazzo, or steel decking the Blitzfire's spikes may not hold well. Placing the spikes into cracks, expansion joints, or gratings or the like will help hold the monitor from sliding. Even with the spikes anchored, sliding may be caused by the surface cracking under the load, or from the hose or nozzle moving the monitor thereby dislodging the spikes from their hold. Figure 6.1.2 shows a close up of a spike caught in a crack.

The holding ability of the spikes on soft surfaces such as sand, gravel and mud is generally poor, therefore other anchoring methods should be considered.

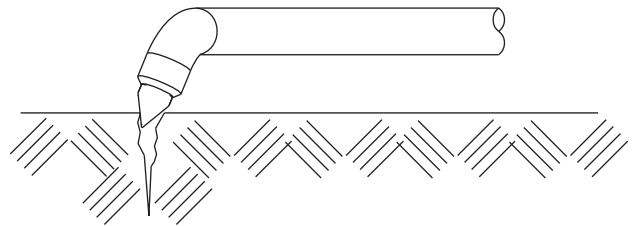

Figure 6.1.2 Spike Caught in a Crack

6.1.3 ANCHORING BY HOOKING LEGS

The legs on the Blitzfire point back slightly so they can act as a hook for anchoring on posts, walls, door frames or other fixed objects. Sliding can occur if the legs are unhooked due to the influence of the hose, nozzle, or operator. See figure 5.3 for illustrations of hooking the legs.

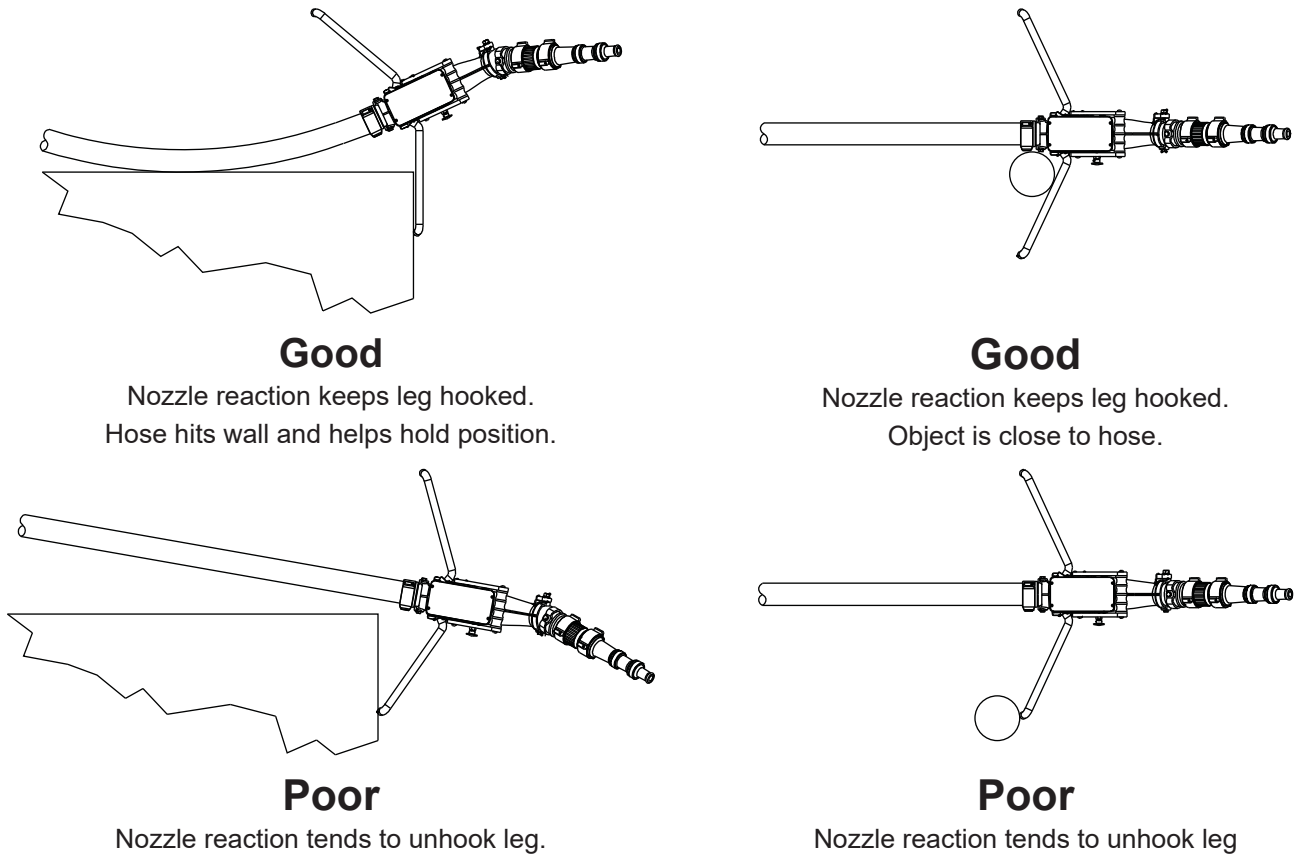

Figure 5.3 Hooking Legs to Gain Support

6.1.4 ANCHORING BY TYING OFF WITH SAFETY STRAP

The safest method of restraining the monitor is to use a tie down strap. It is inherently more reliable than other methods since it does not rely on traction or digging in of the spikes. It is also the safest method because, even if the monitor moves, its travel is limited by the strap. A forward attachment point and a strap are provided with the Blitzfire. A loop on the end of the strap may be placed over the anchor point or the strap may be wrapped around an object, such as a tree, and the snap end of the strap passed through the loop and pulled tight. Keep the entire length of the strap as close to the ground as possible. Snap the hook into the hole in the front of the Blitzfire. If the strap is too short to reach a suitable anchor, it may be extended with strong rope or chain. Keep the distance between the Blitzfire and anchor as short as possible. Remove all slack between the Blitzfire and anchor before flowing water. Figure 6.1.4 shows the elements of tying off the monitor.

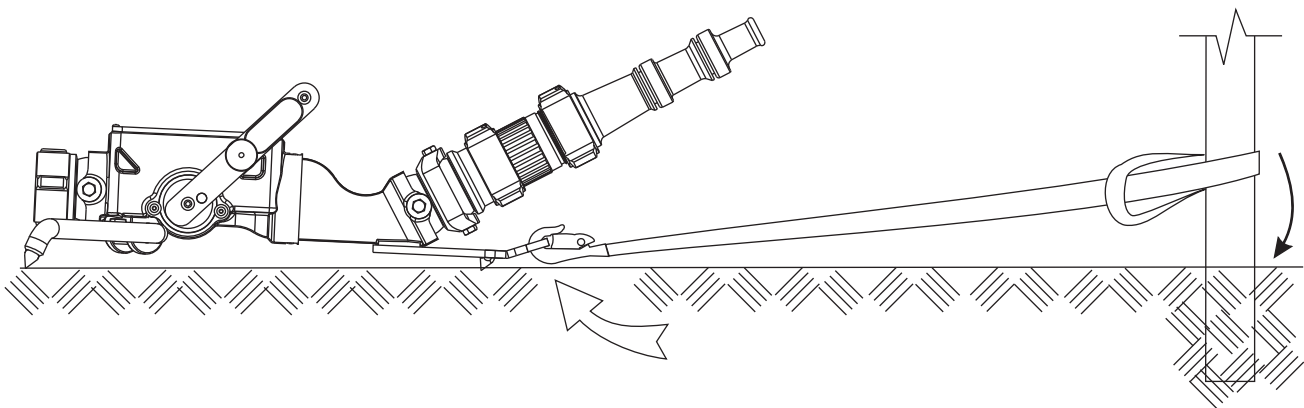

Figure 6.1.4 Tying Off of Blitzfire Monitor

7.0 OSCILLATION UNIT GENERAL INFORMATION

An automatic oscillating mechanism is available for the Blitzfire Monitor. The Blitzfire Monitor can be purchased with the oscillating mechanism factory installed or added at the factory later.

7.1 SAFETY - OSCILLATOR

⚠ DANGER

Do not attempt to modify this oscillating mechanism to fit any other monitor. To do so will cause the reaction force of the nozzle to be unaligned with the center of rotation. The monitor may spin very fast with a very high force.

⚠ WARNING

Keep hands and fingers away from the moving parts of the oscillating unit when water is flowing. There are moving parts that can pinch fingers and hands.

⚠ WARNING

Make sure the Blitzfire is on a firm surface with adequate holding power. As the nozzle goes back and forth, the reaction force is acting in different directions on the leg spikes. Surfaces such as asphalt, turf and dirt generally have good holding power. Surfaces like concrete and loose gravel hold poorly.

⚠ CAUTION

Because the nozzle attached to the Blitzfire must slow down, stop and reverse direction at the end of each sweep, the ends of the covered area will receive more water than the center. If the center area of coverage needs the most cooling, occasionally narrow the area of coverage or use the oscillator manually.

⚠ CAUTION

Because the oscillating mechanism is always moving, the monitor should be manned at all times. When oscillation is disengaged, be prepared for unintended movement of the nozzle.

7.2 VARIOUS MODELS AND TERMS – OSCILLATOR

The Blitzfire oscillating mechanism can be used for exposure protection, cooling, or any other situation where it is desirable to have a monitor sweep back and forth. The horizontal sweep can be set for a 20, 30 and 40 degree sweep. The oscillating mechanism can be uncoupled and the water stream can be aimed manually.

The oscillating mechanism is driven by a turbine wheel. A worm gear drive reduces the speed and increases the torque of the turbine wheel. A simple crank mechanism makes the outlet of the Blitzfire and the nozzle attached to it move back and forth. The horizontal sweep can be set for a 20, 30 and 40 degree sweep. The oscillating mechanism can be uncoupled and the water stream can be aimed manually.

7.3 OPERATION – OSCILLATOR

Operating details for the Blitzfire Oscillator are shown in figure 7.3.

The Blitzfire oscillator is protected by a shock absorber system. If the nozzle encounters an obstruction the shock absorber will compress or extend as needed to protect the gears from overload.

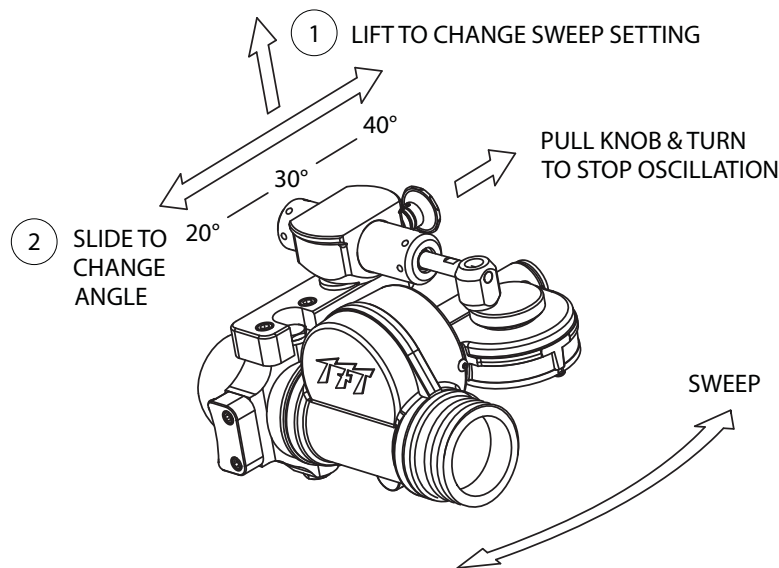

Fig. 7.3 Blitzfire Monitor Oscillator

7.4 OSCILLATION SPEED AND COVERAGE

Oscillation speed: The chart shows how many times per minute the oscillator makes one complete cycle as a function of flow. The higher the flow, the faster it oscillates.

For nozzle reach, refer to the operation manual for the specific nozzle. For reach with oscillation, subtract 20% from the distance.

The speed of oscillation is a function of flow rate, see the Blitzfire Oscillation Speed graph. A minimum flow rate of 175 GPM is required for proper oscillator operation.

APPROXIMATE CYCLES/MIN	GPM	L/MIN
8	175	650
13	250	1000
21	375	1500
28	500	2000

BLITZFIRE OSCILLATION SPEED

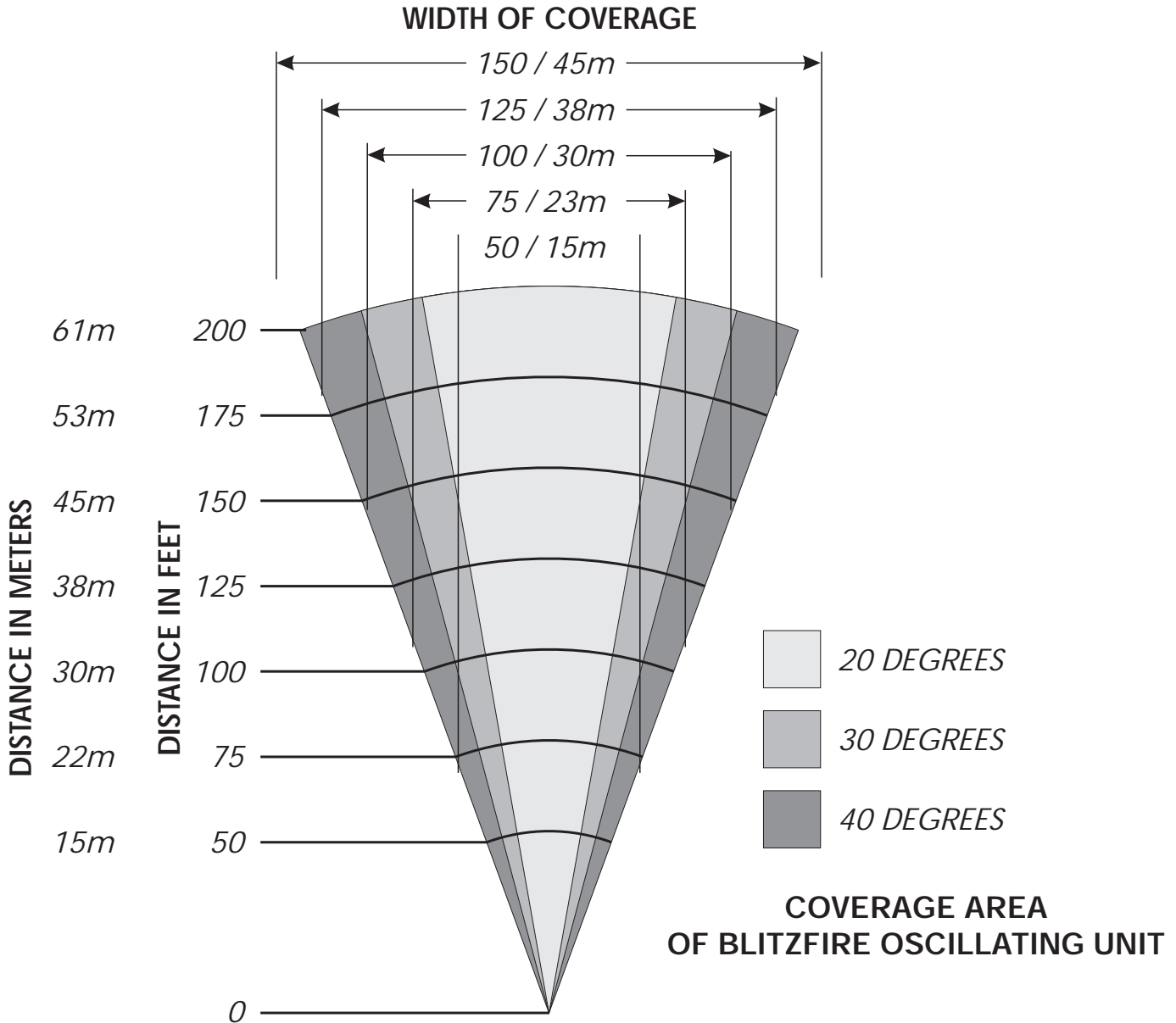

Fig. 7.4 Oscillation Speed and Coverage

NOTICE

The type of nozzle and flow pressure are critical to the coverage area. The graph shows coverage area based on the movement capability of the oscillating mechanism. Actual coverage will depend on flow, pressure, type of nozzle, angle of fog pattern and wind conditions.

8.0 APPROVALS

Many monitor configurations carry the FM Approval rating, NFPA certification, or EN certification.

9.0 STORAGE

The monitor may be stored pre-connected to its hose on the optional storage bracket, TFT part number XX-B. The storage bracket may be mounted on a horizontal surface or a vertical surface with the nozzle end pointing down or sideways. To mount the bracket follow the instructions provided with the bracket kit.

⚠ WARNING

The storage bracket is not intended to support the nozzle reaction forces from a flowing monitor.

10.0 DRAWINGS AND PARTS LISTS

10.1 SAFETY MECHANISM ASSEMBLY VIEW

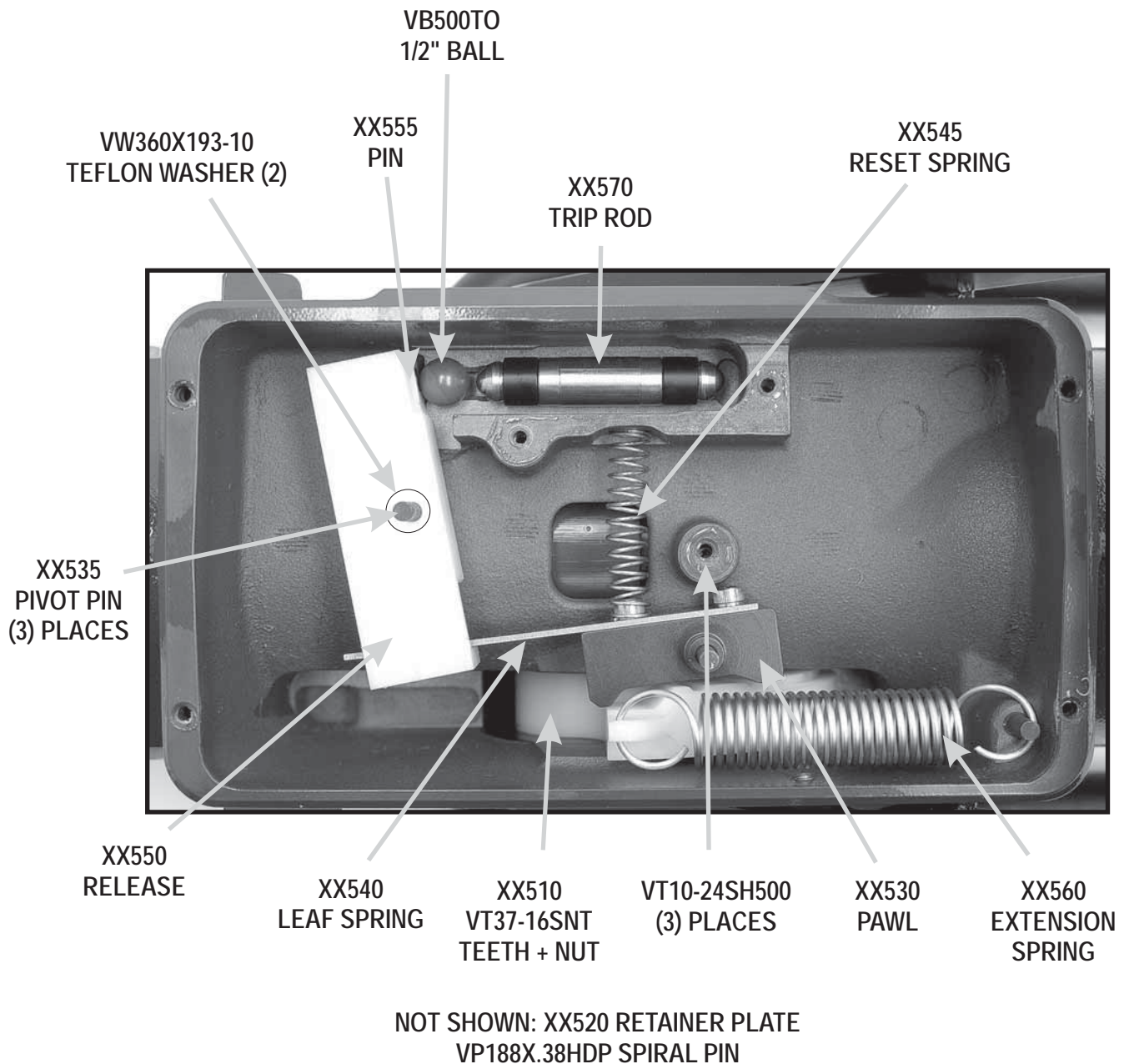

10.2 BLITZFIRE MONITOR EXPLODED VIEW

FOR REPAIR INFORMATION ON THE
AUTOMATIC SHUTOFF OR THE SLOW
CLOSE MECHANISM, CONTACT
TASK FORCE TIPS AT 800-348-2686.

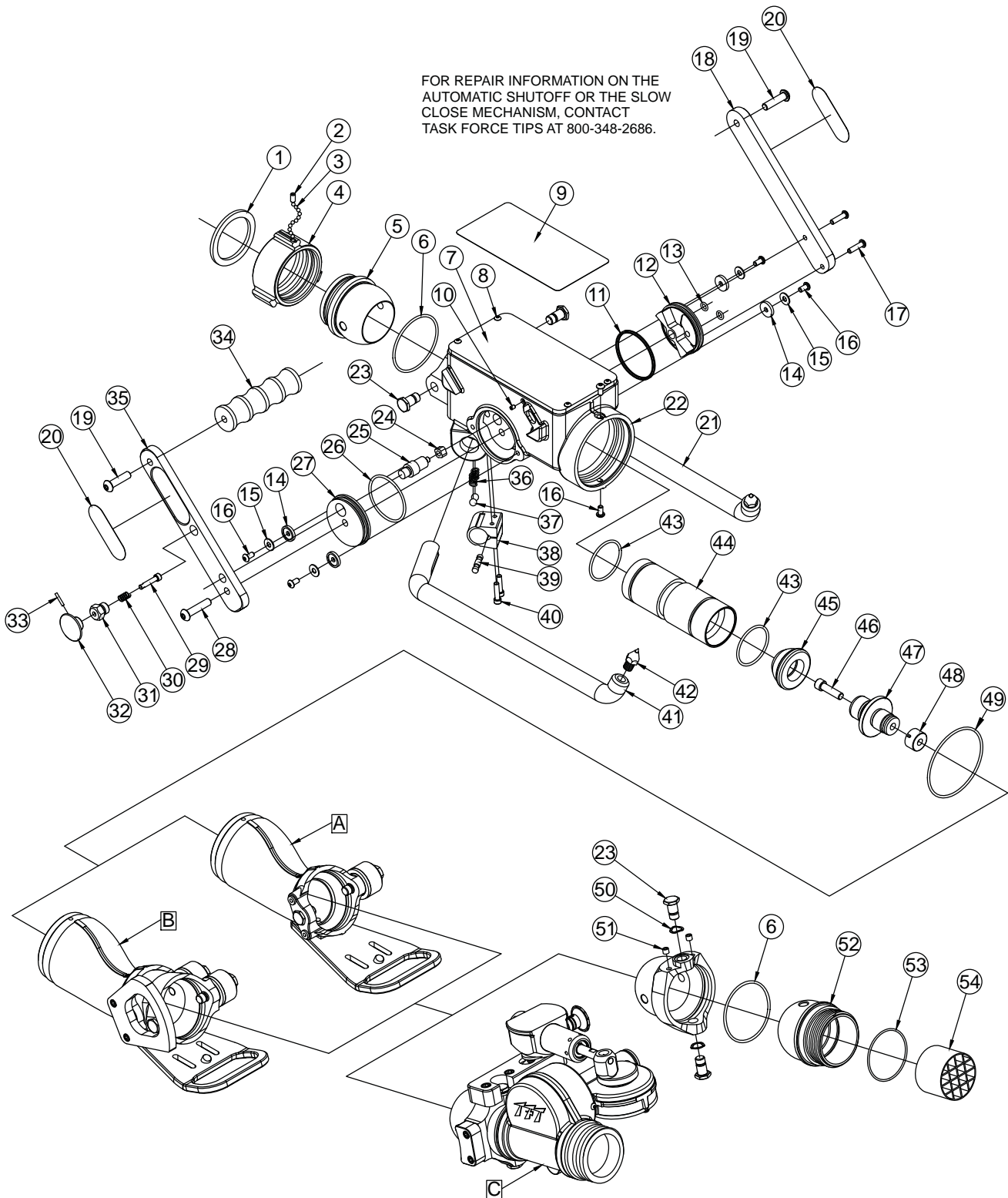

10.2.1 BLITZFIRE MONITOR PARTS LIST

INDEX	DESCRIPTION	QTY	ITEM #
1	GASKET 2.5"	1	V3190
2	1/4-28 X 1/2 SOCKET SET SCREW	1	VT25-28SS500
3	3/16" SS BALL	48	V2120
4	COUPLING 2.5"	1	M307*
5	INLET SWIVEL	1	XX605
6	O-RING-235	1	VO-235
7	COVER PLATE	1	XX205
	COVER PLATE GASKET	1	XX200
8	10-24 1/2 BUTTON HEAD SCREW	4	VT10-24BH500
9	INSTRUCTION LABEL	1	XL670
10	10-24 X 1/4 SOCKET SET SCREW	1	VT10-24SS250
11	QUAD-RING-231	1	VOO-4231
12	DRAG DISK	1	XX645
13	O-RING-109	2	VO-109
14	DISC RETAINER	4	XX642
15	WASHER	4	VW687X281-50
16	1/4-28 X 1/2 BUTTON HEAD SCREW	6	VT25-28BH500
17	1/4-20 X 1 BUTTON HEAD SCREW	2	VT25-20BH1.0
18	LEFT HANDLE	1	XX621
19	3/8-16 X 1-1/2 BUTTON HEAD SCREW	2	VT37-16BH1.5
20	HANDLE LABEL	2	XL620
21	LEFT LEG	1	XX470L
22	BODY	1	XX600
	TRIP MECHANISM	1	XX910
23	SWIVEL TRUNNION	2	XX320
24	SQUARE BUSHING	1	XX630
25	CAM PIN	1	XX610
26	O-RING-230 TEFLON	1	VO-230T
27	DISK	1	XX640
28	3/8-16 X 1.7 BUTTON HEAD SCREW	1	VT37-16BH1.7
29	PULL PIN	1	XX343

INDEX	DESCRIPTION	QTY	ITEM #
30	PULL PIN SPRING	1	XX342
31	PULL PIN HOUSING	1	XX355
32	PULL KNOB	1	XX341
33	1/8 X 3/4 HDP SPIROL PIN	1	VP125X750H
34	HANDLE TOP	1	XX625
35	RIGHT HANDLE	1	XX620
36	DETENT SPRING	4	XX655
37	3/8" TORLON BALL	4	VB375TO
38	LEG RETAINER	2	XX475
39	LEG RETAINER PIN	2	XX476
40	1/4-20 X 1 SOCKET HEAD SCREW	4	VT25-20SH1.0
41	RIGHT LEG	1	XX470R
42	REAR SPIKE	2	X482
43	O-RING-227	2	VO-227
44	SLIDER	1	XX660
45	VALVE PLUG	1	XX590
46	3/8-24 X 1-3/4 SOCKET HEAD SCREW	1	VT37-24SH175
47	PLUG SUPPORT	1	XX594
48	LOCKING SLEEVE	1	XX571
49	O-RING-241	1	VO-241
50	WAVE SPRING WASHER	2	VW740X550-16
51	5/16-18 X 1/4 SOCKET SET SCREW	2	VT31-18SS250
52	EXIT 2.5"	1	XX310*
53	O-RING-146	1	VO-146
54	STREAM STRAIGHTENER INSERT	1	XXL406
A	BLITZFIRE OUTLET	1	SEE SECTION 10.3
B	HIGH ELEVATION BLITZFIRE OUTLET	1	SEE SECTION 10.4
C	HIGH ELEVATION BLITZFIRE OSCILLATOR	1	SEE SECTION 10.5

* - CONSULT FACTORY FOR SPECIAL THREADS

10.3 STANDARD BLITZFIRE OUTLET EXPLODED VIEW

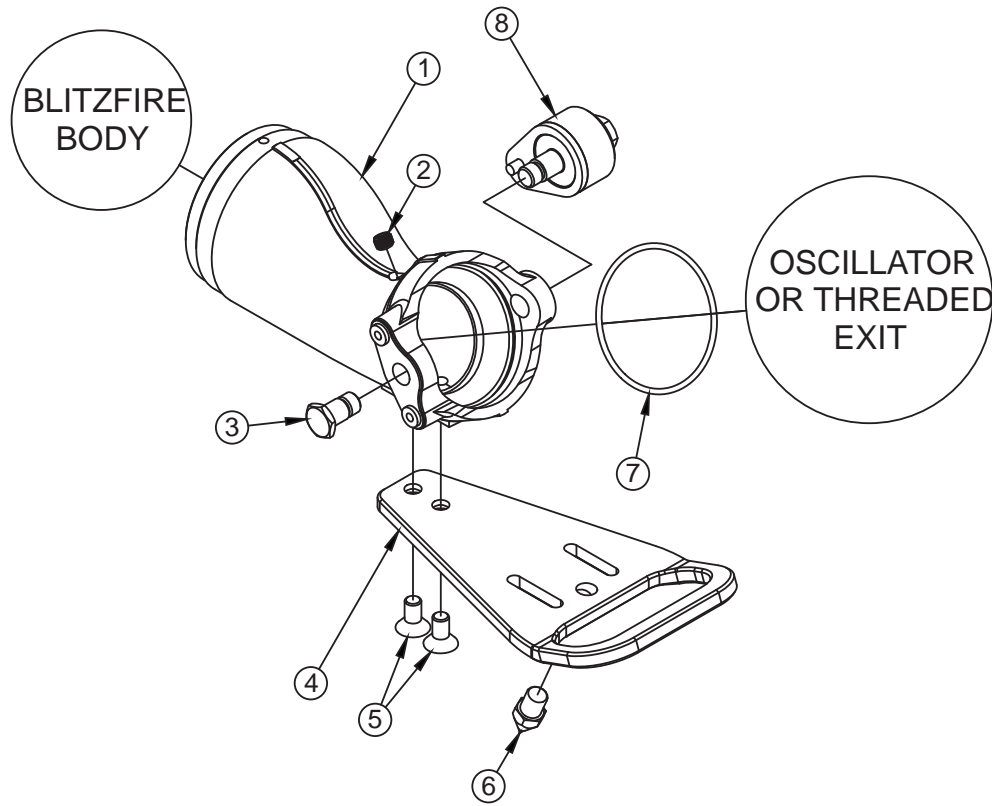

10.3.1 STANDARD BLITZFIRE OUTLET PARTS LIST

INDEX	DESCRIPTION	QTY	ITEM #
1	OUTLET	1	XX420
2	1/8 NPT PLUG	1	VFSP1M SS
3	SWIVEL TRUNNION	3	XX320
4	FRONT LEG	1	XX460
5	3/8-16 X 1/2 FLAT HEAD SOCKET SCREW	2	VT37-16FH750
6	SPIKE	1	X480
7	O-RING-235	1	VO-235
8	RATCHET CLUTCH	1	XX830-KIT

10.4 HIGH ELEVATION BLITZFIRE OUTLET EXPLODED VIEW

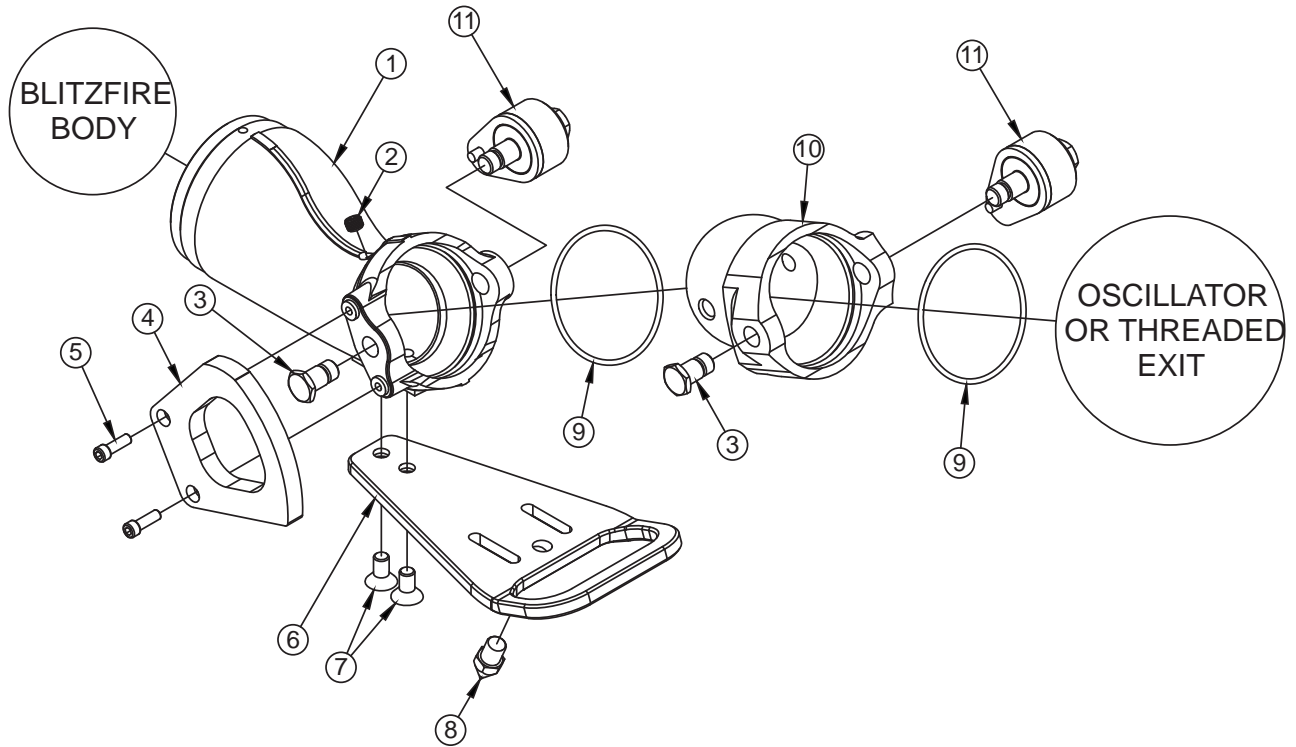

10.4.1 HIGH ELEVATION BLITZFIRE OUTLET PARTS LIST

INDEX	DESCRIPTION	QTY	ITEM #
1	OUTLET	1	XX420
2	1/8 NPT PLUG	1	VFSP1M SS
3	SWIVEL TRUNNION	4	XX320
4	CAM	1	XX322
5	1/4-20 X 1 SOCKET HEAD SCREW	4	VT25-20SH1.0
6	FRONT LEG	1	XX460
7	3/8-16 X 1/2 FLAT HEAD SOCKET SCREW	2	VT37-16FH750
8	SPIKE	1	X480
9	O-RING-235	3	VO-235
10	1ST SEGMENT	1	XX306
11	RATCHET CLUTCH	2	XX830-KIT

10.5 OSCILLATOR EXPLODED VIEW

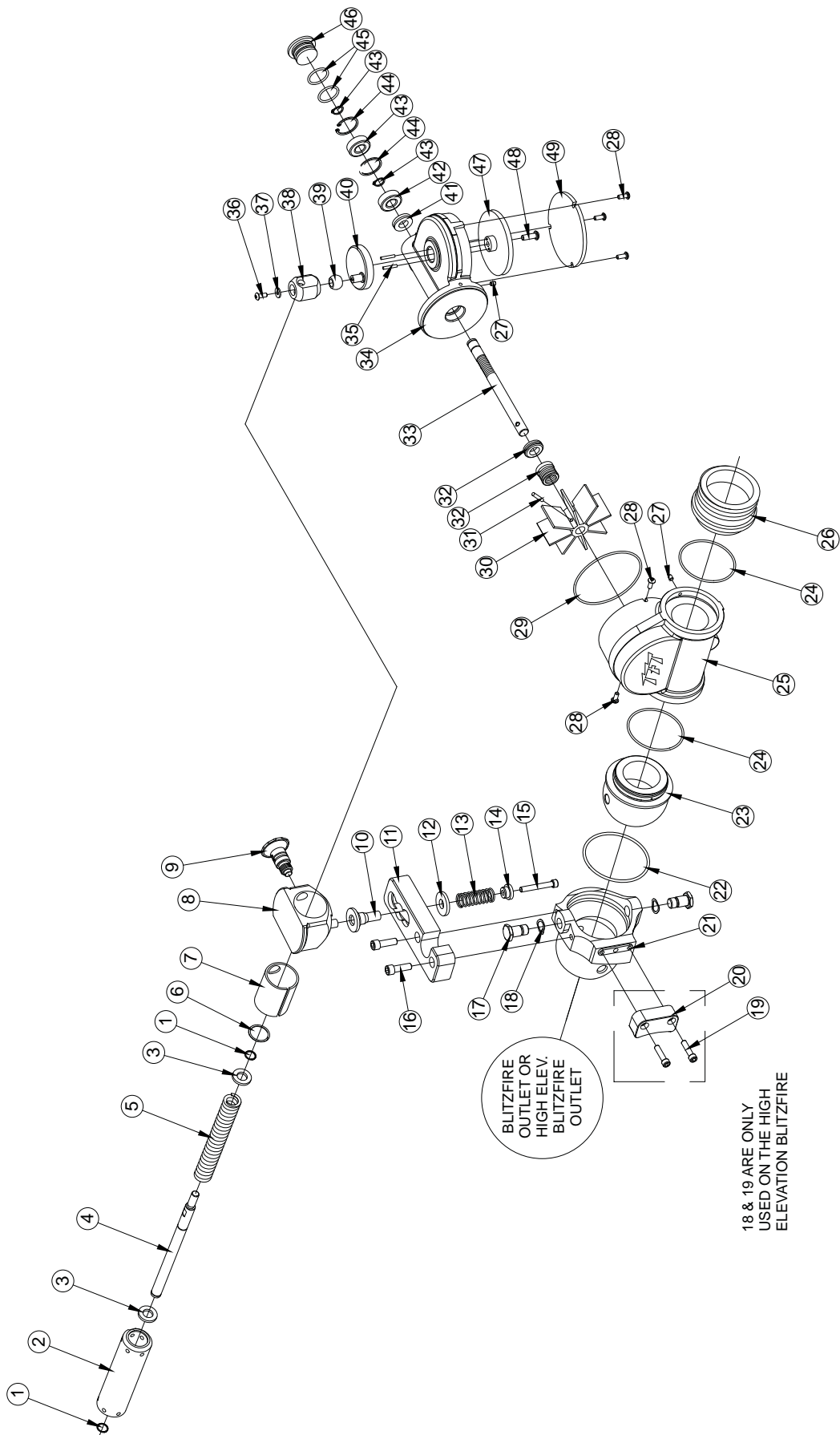

10.5.1 OSCILLATOR PARTS LIST

INDEX	DESCRIPTION	QTY	ITEM #
1	SMALLEY RING	2	V4280
2	SPRING TUBE	1	XX367
3	WASHER	2	XX364
4	LINK	1	XX363
5	SPRING	1	XX371
6	SMALLEY RING	1	VR4340
7	SPRING TUBE BUSHING	1	XX382
8	SLIDER BLOCK	1	XX368
9	LATCHING PULL PIN SUBASSEMBLY	1	XX935
10	DETENT BUSHING	1	XX376
11	ARM	1	XX061
12	WASHER	1	XX377
13	SPRING	1	C031
14	SPRING RETAINER	1	XX378
15	1/4-20 X 1.75 SOCKET HEAD SCREW	1	VT25-20SH1.7
16	5/16-18 X 1 SOCKET HEAD SCREW	2	VT31-18SH1.0
17	SWIVEL TRUNNION	2	XX320
18	WAVE SPRING WASHER	2	VW740X550-16
19	1/4-20 X 1 SOCKET HEAD SCREW	2	VT25-20SH1.0
20	CAM FOLLOWER	1	XX323
21	2ND SEGMENT	1	XX307
	EXIT SEGMENT		XX305
22	O-RING-235	1	VO-235
23	INLET BALL	1	XX015
24	O-RING-147	2	VO-147
25	WATERWAY	1	XX010
26	EXIT OSC 2.5"	1	XX020*
27	10-32 X 1/4 SOCKET SET SCREW	3	VT10-32SS250
28	10-32 X 1/2 BUTTON HEAD SCREW	5	VT10E32BH500
29	O-RING-153	1	VO-153
30	TURBINE VANES	1	XX025
31	5/32 X 7/8 HDP SPIROL PIN	1	V1900
32	TURBINE SEAL	1	XX032
33	WORM AND SHAFT	1	XX030
34	GEAR BOX	1	XX005
35	1/8 X 3/4 HDP SPIROL PIN	2	VP125X750H
36	10-32 X 1/2 BHCS - NYLOK PATCH	1	VT10Y32BH500
37	WASHER	1	VW500X203-60
38	OFFSET ROD END	1	XX057
39	SPHERICAL BUSHING	1	XX058
40	CRANK	1	XX362
41	CUP SEAL	1	XX033
42	WORM SHAFT BEARING	2	XX035
43	SNAP RING 1/2" EXTERNAL	2	VR4250
44	SNAP RING 1-1/8 INTERNAL	2	VR4255
45	O-RING-119	2	VO-119
46	SHAFT CAP	1	XX037
47	WORM GEAR	1	XX040
48	1/4-20 X 7/8 SOCKET HEAD SCREW	1	VT25-20SH875
49	COVER	1	XX045
* - CONSULT FACTORY FOR SPECIAL THREADS			

11.0 WARRANTY

Task Force Tips, Inc., 3701 Innovation Way, Valparaiso, Indiana 46383-9327 USA (“TFT”) warrants to the original purchaser of its Blitzfire Monitor (“equipment”), and to anyone to whom it is transferred, that the equipment shall be free from defects in material and workmanship during the five (5) year period from the date of purchase.

TFT’s obligation under this warranty is specifically limited to replacing or repairing the equipment (or its parts) which are shown by TFT’s examination to be in a defective condition attributable to TFT. To qualify for this limited warranty, the claimant must return the equipment to TFT, at 3701 Innovation Way, Valparaiso, Indiana 46383-9327 USA, within a reasonable time after discovery of the defect. TFT will examine the equipment. If TFT determines that there is a defect attributable to it, it will correct the problem within a reasonable time. If the equipment is covered by this limited warranty, TFT will assume the expenses of repair.

If any defect attributable to TFT under this limited warranty cannot be reasonably cured by repair or replacement, TFT may elect to refund the purchase price of the equipment, less reasonable depreciation, in complete discharge of its obligations under this limited warranty. If TFT makes this election, claimant shall return the equipment to TFT free and clear of any liens and encumbrances.

This is a limited warranty. The original purchaser of the equipment, any person to whom it is transferred, and any person who is an intended or unintended beneficiary of the equipment, shall not be entitled to recover from TFT any consequential or incidental damages for injury to person and/or property resulting from any defective equipment manufactured or assembled by TFT. It is agreed and understood that the price stated for the equipment is in part consideration for limiting TFT’s liability. Some states do not allow the exclusion or limitation of incidental or consequential damages, so the above may not apply to you.

TFT shall have no obligation under this limited warranty if the equipment is, or has been, misused or neglected (including failure to provide reasonable maintenance) or if there have been accidents to the equipment or if it has been repaired or altered by someone else.

THIS IS A LIMITED EXPRESS WARRANTY ONLY. TFT EXPRESSLY DISCLAIMS WITH RESPECT TO THE EQUIPMENT ALL IMPLIED WARRANTIES OF MERCHANTABILITY AND ALL IMPLIED WARRANTIES OF FITNESS FOR A PARTICULAR PURPOSE. THERE IS NO WARRANTY OF ANY NATURE MADE BY TFT BEYOND THAT STATED IN THE DOCUMENT.

This limited warranty gives you specific legal rights, and you may also have other rights which vary from state to state.

Visit TFT’s web site at www.tft.com

12.0 MAINTENANCE

The Blitzfire Portable Monitor requires little maintenance. The unit should be kept clean and free of dirt by rinsing with water after each use. Any inoperable or damage parts should be repaired or replaced before placing the unit in service.

In applications where appliances are left continuously connected to the apparatus or other devices or are used where water is trapped inside the appliance, the appliance must be flushed with fresh water following each use and inspected for damage.

This monitor should be disconnected, cleaned and visually inspected inside and out at least quarterly, or as water quality and use may require. Moving parts such as handles, valve ball and couplings should be checked for smooth and free operation. Seals shall be greased as needed with Silicone based grease such as Dow Corning 112. Any scrapes that expose bare aluminum should be cleaned and touched up with enamel paint such as Rust-Oleum. Replace any missing or damaged parts before returning to service.



Any alterations to the monitor and it’s markings could diminish safety and constitutes a misuse of this product.

Any Blitzfire taken out of service due to failure should be returned to the factory for repair or replacement. If you have any questions regarding the testing or maintenance of your valve, please call Task Force Tips at 800-348-2686.

12.1 SERVICE TESTING

In accordance with NFPA 1962 (2013), monitors must be tested a minimum of annually. Nozzles failing any part of this test must be removed from service, repaired and retested upon completion of the repair.

12.1.1 HYDRAULIC TEST

1. *The appliance being tested shall be positioned in a protective device or cover capable of holding the appliance and tested to a minimum hydrostatic pressure of 300 psi (20.7 bar or 2070 kPa).*
2. *Test caps capable of withstanding the required hydrostatic pressure shall be attached to openings, and a device capable of exerting the required hydrostatic pressure shall be attached to the appliance.*
3. *Appliances with relief valves shall have the relief valve outlet blanked off or otherwise closed during the test.*
4. *All air shall be bled from the system.*
5. *The gauge pressure shall be increased by 50 psi (3.45 bar or 345 kPa) increments and held for 30 seconds at each pressure up to the maximum pressure for which the appliance is being tested and held for 1 minute without leakage.*

12.1.2 SHUTOFF VALVE TEST

1. *If the appliance has a shutoff valve, the intake side of the shutoff valve shall be hydrostatically pressurized to the maximum working pressure of the appliance with the valve in the shutoff position.*
2. *There shall be no leakage through the valve.*
3. *A water flow through the fire hose appliance at 100 psi (6.9 bar or 690 kPa) shall be established.*
4. *The valve shall be closed and reopened twice and shall operate smoothly without evidence of binding or other problems.*

12.1.3 RECORDS

A record of testing and repairs must be maintained from the time the monitor is purchased until it is discarded. Each TFT monitor is engraved with a unique serial number which, if so desired, can be used to identify monitor for documentation purposes.

The following information, if applicable, must be included on the test record for each monitor:

1. *Assigned identification number*
2. *Manufacturer*
3. *Product or model designation*
4. *Vendor*
5. *Warranty*
6. *Hose connection size*
7. *Maximum operating pressure*
8. *Flow rate or range*
9. *Date received and date put in service*
10. *Date of each service test and service test results*
11. *Damage and repairs, including who made the repairs and the cost of repair parts*
12. *Reason removed from service*

NFPA 1962: Standard for the care, use, inspection, service testing, and replacement of fire hose, couplings, nozzles and fire hose appliances. (2013 ed., Section 6.4.4). Quincy, MA: National Fire Protection Agency.

12.2 REPAIR

Factory service is available with repair time seldom exceeding one day in our facility. Factory serviced appliances are repaired by experienced technicians to original specifications, fully tested and promptly returned.

Repair parts and service procedures are available for those wishing to perform their own repairs. Task Force Tips assumes no liability for damage to equipment or injury to personnel that is a result of user service.

For additional information on care, maintenance and testing, refer to: NFPA 1962: Standard for the Care, Use, Inspection, Service Testing, and Replacement of Fire Hose, Couplings, Nozzles, and Fire Hose Appliances, 2013 Edition

13.0 ANSWERS TO YOUR QUESTIONS

We appreciate the opportunity of serving you and making your job easier. If you have any problems or questions, our toll-free "Hydraulics Hotline", 800-348-2686, is normally available to you 24 hours a day, 7 days a week.

14.0 OPERATION and INSPECTION CHECKLIST

BEFORE BEING PLACED BACK IN SERVICE, appliances must be inspected to this list:

1. All valves open and close smoothly and fully.
2. The waterway is clear of obstructions.
3. There is no damage to any thread or other type connection.
4. The pressure setting of the relief valve, if any, is set correctly.
5. All locks and hold-down devices work properly.
6. Internal gaskets are in accordance with NFPA 1962 (2013) Section 7.2.
7. There is no damage to the appliance (e.g., dents, cracks, corrosion, or other defects that could impair operation).
8. All swiveling connections rotate freely.
9. There are no missing parts or components.
10. The marking for maximum operating pressure is visible.
11. There are no missing, broken, or worn lugs on couplings.

NFPA 1962: Standard for the care, use, inspection, service testing, and replacement of fire hose, couplings, nozzles and fire hose appliances. (2013 ed., Section 6.2.1). Quincy, MA: National Fire Protection Agency.

BEFORE EACH USE, appliances must be inspected to this list:

- 1 • There is no damage to the appliance that could impair safe operation (e.g. dents, cracks, corrosion, missing, broken or loose parts, damaged markings, or other defects)
 - Waterway is clear of obstructions
 - Gaskets are in good repair
 - Hose and nozzle are securely attached.
 - The pressure setting on the relief valve (if so equipped) is set correctly

5 Monitor is anchored:

- Tied off
- Hooked leg
- Spike hold
- Weight

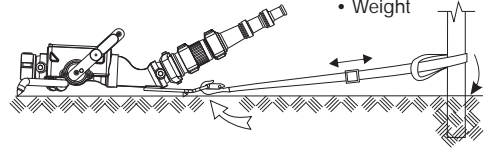

- 2 Both legs are fully open. All three spikes are in contact with the ground.

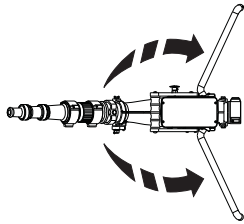

6 Outlet pivots smoothly in all directions.

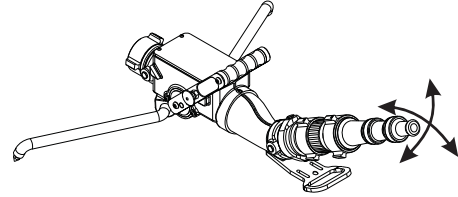

- 3 Valve handle locks when closed and releases.

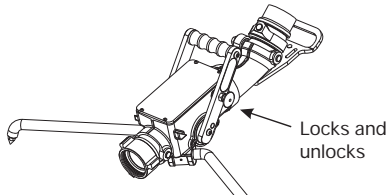

Locks and unlocks

7 Safety Shut-Off valve is operational. (see section 3.3.3)

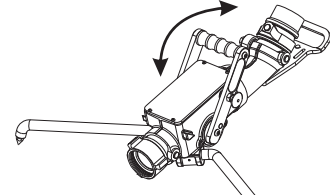

- 4 Inlet pivots freely.

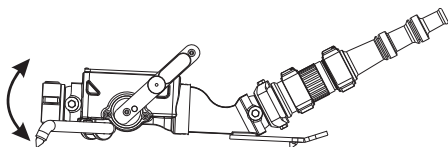

8 Monitor is pointed in a safe direction.

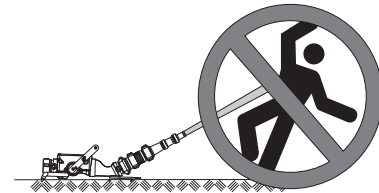

⚠️ WARNING

Any Blitzfire monitor failing any part of the inspection checklist is unsafe and must have the problem corrected before use. Operating a Blitzfire that fails any of the above inspections is a misuse of this equipment.

TASK FORCE TIPS, INC.
MADE IN USA • www.tft.com

3701 Innovation Way, Valparaiso, IN 46383-9327 USA
800-348-2686 • 219-462-6161 • Fax 219-464-7155