

INSTALLATION INSTRUCTIONS: CROSSFIRE SENSOR KIT

The X-SENSOR-KIT is an optional kit for a Crossfire and Extend-A-Gun installation. The kit replaces the standard sensor installed on the Extend-A-Gun. It is used to ensure the Extend-A-Gun is lowered, and the Crossfire outlet is properly stowed. The cradle houses a sensor that senses a magnet located in the Crossfire Monitor outlet. The Monitor Extended Warning Light will activate anytime the monitor outlet is rotated or elevated away from the stow position.

Installation Instructions:

1. Determine stow position for monitor and nozzle as seen in Figure 1.
2. Drill or tap deck for two 1/4-20 screws according to Fig 2.
3. The cradle must nearly touch the Crossfire when the elbow is the horizontal position. Stack up spacers under cradle in any configuration shown in Fig. 3 to ensure adequate height.
4. Install cradle with two 1/4-20 socket head screws of sufficient length.

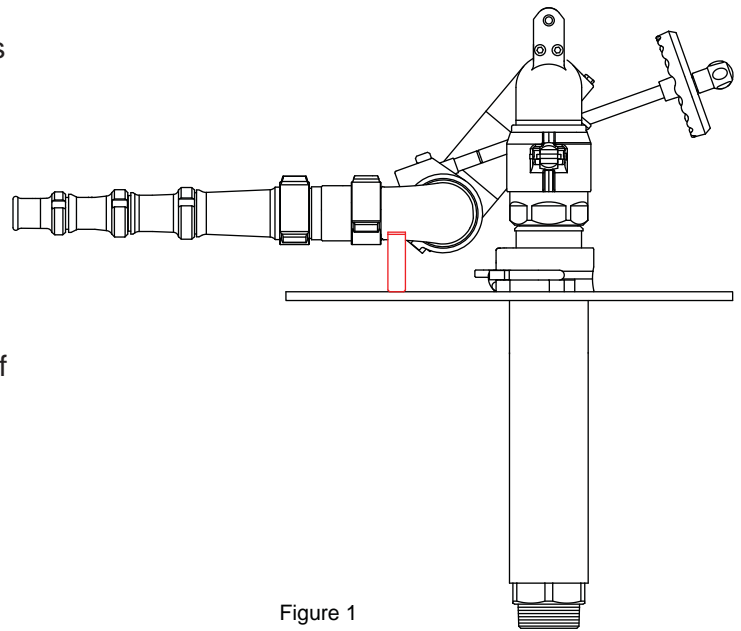

Figure 1

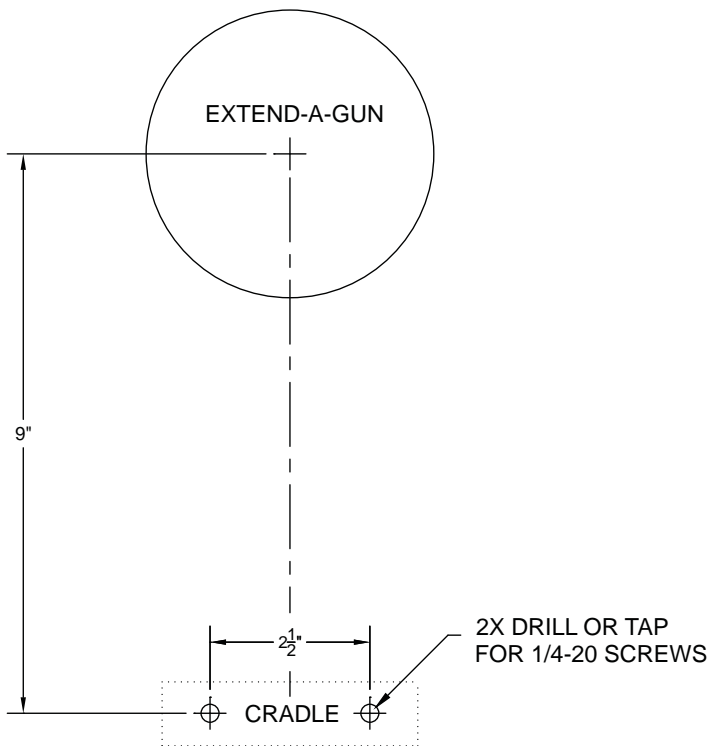

Figure 2

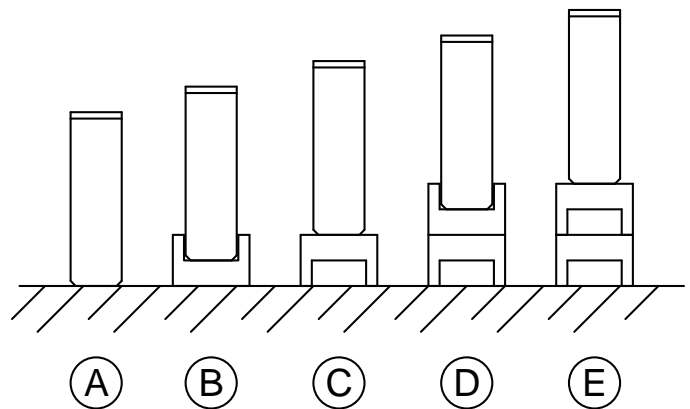
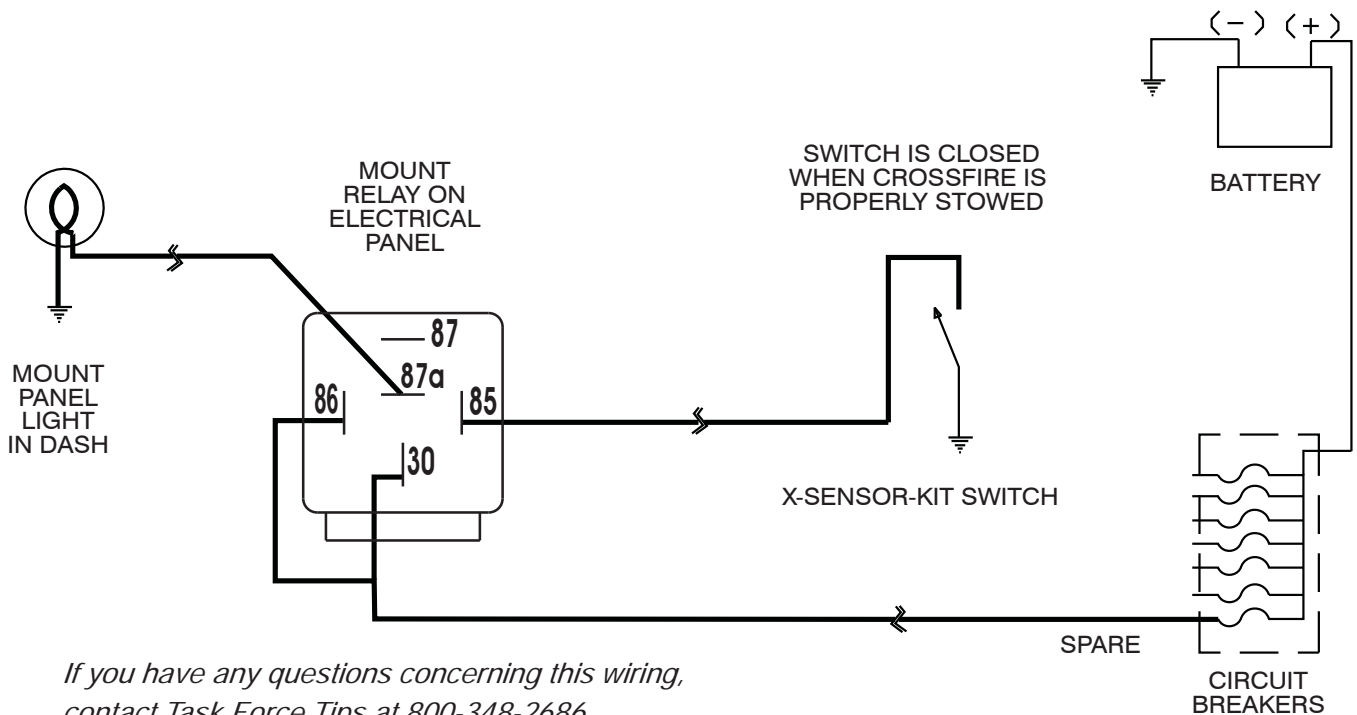

Figure 3

The crossfire sensor contains a magnetic switch. This switch is intended to be used with a MONITOR EXTENDED warning light. The magnetic switch in the Crossfire Sensor is a normally open switch, and the switch is closed when the crossfire is in the down position. The relay packaged with the Extend-A-Gun MUST BE USED to limit the current through the switch.

Use the wiring diagram below.

1. Install the sensor cradle on the truck according to the bolting diagram.
2. Mount the relay on the electrical panel with the terminals accessible.
3. Drill a 1/2" diameter hole in the dash board for the panel light. Leave enough room for a 1-13/16" diameter label around the light or a 2" wide x 1-1/2" high label next to the light. Apply one of the two warning labels and push the panel label through the hole in the dash.
4. Connect the labeled wires on the switch to the terminal #85 on the relay and ground respectively.
5. Connect the terminals on the panel light to terminal #87A on the relay and ground respectively.
6. Connect a wire from a "spare" position on the truck's circuit breaker panel to terminals #30 and #86. The circuit from the "spare" position in the fuse block should only be energized with the ignition switch is in the ON position.



If you have any questions concerning this wiring, contact Task Force Tips at 800-348-2686.