



CROSSFIRE® Monitor

with Safe-Tak™ 1250 Base

INSTRUCTIONS FOR INSTALLATION, OPERATION, AND MAINTENANCE

⚠ DANGER

Understand manual before use. Operation of this device without understanding the manual and receiving proper training is a misuse of this equipment. Obtain safety information at tft.com/ serial-number.

This equipment is intended for use by trained and qualified emergency services personnel for firefighting. All personnel using this equipment shall have completed a course of education approved by the Authority Having Jurisdiction (AHJ).

This instruction manual is intended to familiarize firefighters and maintenance personnel with the operation, servicing, and safety procedures associated with this product. This manual should be kept available to all operating and maintenance personnel.

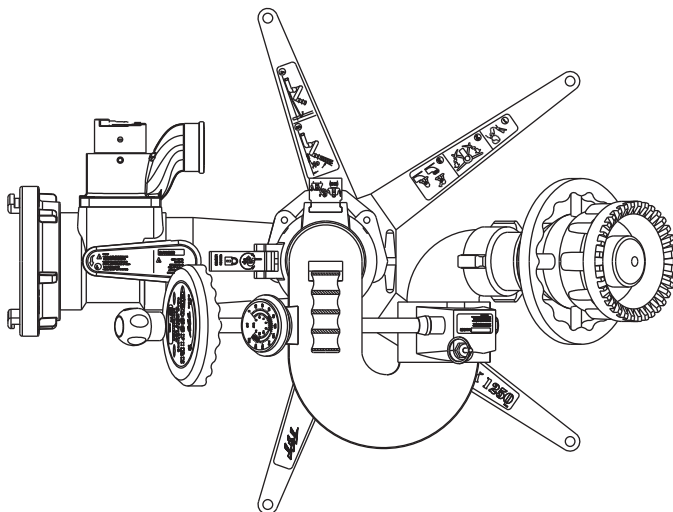
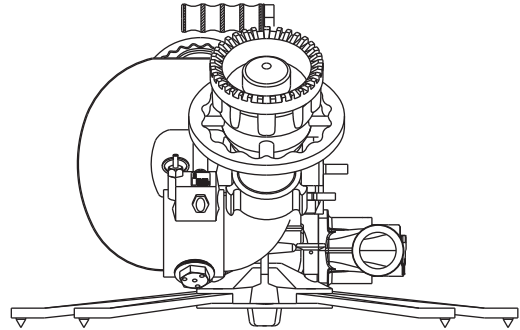
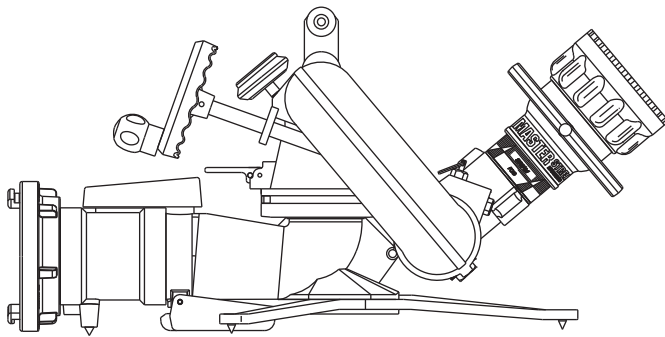

Shown with optional PRV

See Section [3.4](#)
for Flow/Pressure
Operating Envelope

TASK FORCE TIPS LLC
MADE IN USA · tft.com

3701 Innovation Way, Valparaiso, IN 46383-9327 USA
800-348-2686 · 219-462-6161 · Fax 219-464-7155

DANGER

PERSONAL RESPONSIBILITY CODE

The member companies of FEMSA that provide emergency response equipment and services want responders to know and understand the following:

1. **Firefighting and Emergency Response are inherently dangerous activities requiring proper training in their hazards and the use of extreme caution at all times.**
2. **IT IS YOUR RESPONSIBILITY to read and understand any user's instructions, including purpose and limitations, provided with any piece of equipment you may be called on to use.**
3. **IT IS YOUR RESPONSIBILITY to know that you have been properly trained in Firefighting and/or Emergency Response and in the use, precautions, and care of any equipment you may be called upon to use.**
4. **IT IS YOUR RESPONSIBILITY to be in proper physical condition and to maintain the personal skill level required to operate any equipment you may be called upon to use.**
5. **IT IS YOUR RESPONSIBILITY to know that your equipment is in operable condition and has been maintained in accordance with the manufacturer's instructions.**
6. **Failure to follow these guidelines may result in death, burns or other severe injury.**

Fire and Emergency Manufacturers and Service Association, Inc.
PO Box 147, Lynnfield, MA 01940 • www.FEMSA.org



© 2020 FEMSA. All Rights Reserved.

SUPPORTING MATERIALS

The following documents contain supporting safety and operating information pertaining to the equipment described in this manual.

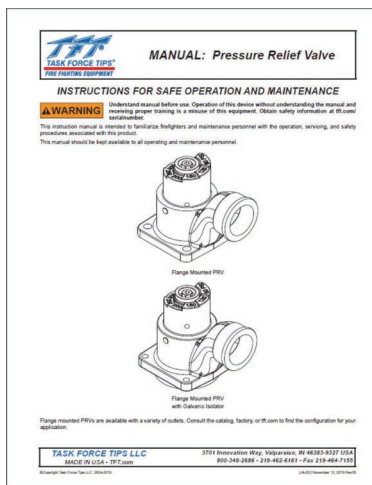

LIA-020 Pressure Relief Valve

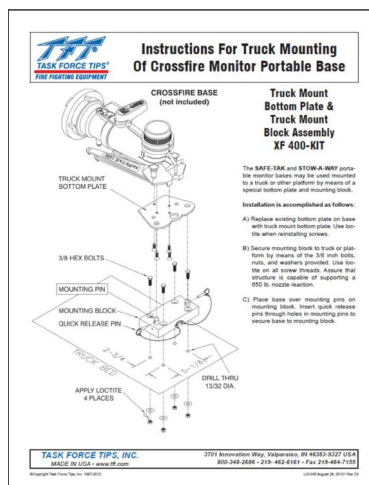

LIX-045 Instructions for Truck Mounting of Crossfire Monitor Portable Base



LIX-034 Installation Instructions for XF-B Crossfire Mounting Bracket

TABLE OF CONTENTS

- 1.0 MEANING OF SAFETY SIGNAL WORDS
- 2.0 SAFETY
- 3.0 GENERAL INFORMATION
 - 3.1 VARIOUS MODELS AND TERMS
 - 3.2 SPECIFICATIONS
 - 3.3 USE WITH SALT WATER
 - 3.4 OPERATING ENVELOPE
- 4.0 OPERATING INSTRUCTIONS
 - 4.1 QUICK CONNECT SWIVEL JOINT
 - 4.2 INSTALLING THE MONITOR TOP ON THE BASE
 - 4.3 REMOVING THE MONITOR TOP FROM THE BASE
 - 4.4 POSITIONING THE STREAM
 - 4.4.1 HORIZONTAL ROTATION AND LOCK
 - 4.4.2 ELEVATION CONTROL AND STOP PIN
 - 4.5 AUTOMATIC DRAIN
 - 4.6 TRUCK MOUNT BASE
 - 4.7 TRUCK MOUNTING OF THE PORTABLE BASE
 - 4.8 FLOW CHARACTERISTICS
 - 4.8.1 STACKED TIPS
 - 4.8.2 AUTOMATIC MASTER STREAM NOZZLES
 - 4.8.3 STREAM STRAIGHTENERS
 - 4.8.4 PRESSURE LOSS
 - 4.9 TRANSPORTING MONITOR ON THE TRUCK MOUNT BASE
- 5.0 SAFE-TAK 1250 BASE
 - 5.1 SITE SELECTION
 - 5.2 EXTENDING PORTABLE BASE LEGS
 - 5.3 RETRACTING PORTABLE BASE LEGS
 - 5.4 CARBIDE SPIKES
 - 5.5 ANCHORING BY USING THE TIE DOWN STRAP
 - 5.6 PORTABLE BASE SAFETY VALVE
 - 5.7 HOSE CONNECTION
 - 5.8 PRESSURE RELIEF OPTION
 - 5.8.1 PRESSURE RELIEF VALVE SETTING
- 6.0 WARRANTY
- 7.0 MAINTENANCE
 - 7.1 GREASING THE WORM GEAR
 - 7.2 SERVICE TESTING
 - 7.3 REPAIR
- 8.0 EXPLODED VIEW AND PARTS LISTS
- 9.0 OPERATION AND INSPECTION CHECKLIST

1.0 MEANING OF SAFETY SIGNAL WORDS

A safety related message is identified by a safety alert symbol and a signal word to indicate the level of risk involved with a particular hazard. Per ANSI Z535.6, the definitions of the four signal words are as follows:



DANGER indicates a hazardous situation which, if not avoided, will result in death or serious injury.



WARNING indicates a hazardous situation which, if not avoided, could result in death or serious injury.



CAUTION indicates a potentially hazardous situation which, if not avoided, could result in minor or moderate injury.



NOTICE is used to address practices not related to physical injury.

2.0 SAFETY



An inadequate supply of pressure and/or flow will cause an ineffective stream and can result in injury or death. Choose operating conditions to deliver adequate fire suppression. See flow graphs.



Low nozzle elevation angles can cause portable monitors to slide or lift off the ground which can result in injury or death from an out of control monitor. Do not operate the monitor below the elevation safety stop while on the portable base.



Sudden change in position of an improperly secured monitor can result in an out of control monitor. An out of control monitor can spray water in unintended directions or become a projectile, causing serious injury or death. To reduce the risk of an out of control monitor:

- Do not attempt to move the monitor while flowing
- Keep elevation as high as practical
- Test Shut-off valve before each use
- Securely tie off monitor to an immovable object
- Ensure all legs are in the unfolded position
- Hook legs on stationary objects such as door frames, sign posts, etc.
- Choose surfaces that allow all spikes to contact the ground
- Do not place the monitor on top of debris, objects, or uneven terrain
- Assure that the hose is not lifting spikes off the ground
- If stability is questionable, reduce flow to limit reaction

In the event of an out of control monitor:

- Immediately retreat to a safe distance
- Shut down the water hose at its source before attempting to re-secure the monitor



Interrupting flow to the monitor could cause injury or death. Avoid situations that may interrupt flow to the monitor such as hose line kinks, traffic running over hose, and automatic doors or devices that can pinch the hose.



The stream exiting a nozzle is very powerful and capable of causing injury and property damage. Make sure the nozzle is securely attached and pointing in a safe direction before water is turned on. Do not direct water stream to cause injury or damage to persons or property.



Equipment may be damaged if frozen while containing significant amounts of water. Such damage may be difficult to detect visually. Subsequent pressurization can lead to injury or death. Any time the equipment is subject to possible damage due to freezing, it must be tested and approved for use by qualified personnel before being considered safe for use.



Mismatched or damaged waterway connections may cause equipment to leak or uncouple under pressure. Failure could result in injury. Equipment must be mated to matched connections.



Dissimilar metals coupled together can cause galvanic corrosion that can result in the inability to uncouple the connection, or complete loss of engagement over time. Failure could cause injury. Per NFPA 1962, if dissimilar metals are left coupled together, an anti-corrosive lubricant should be applied to the connection and the coupling should be disconnected and inspected at least quarterly.



To prevent mechanical damage, do not drop or throw equipment.

3.0 GENERAL INFORMATION

The CROSSFIRE monitor is the most rugged and innovative deck/portable master stream device ever offered to the fire service. This efficient, compact, and easy to maneuver portable monitor can be mounted in a pre-connected state on the truck-mounting bracket for achieving quick and effective initial attack.

3.1 VARIOUS MODELS AND TERMS

The CROSSFIRE monitor is available in several different models and inlet connections. The following figures identify the various parts and controls of the CROSSFIRE monitor, Safe-Tak 1250 portable base, and truck mount adaptor.

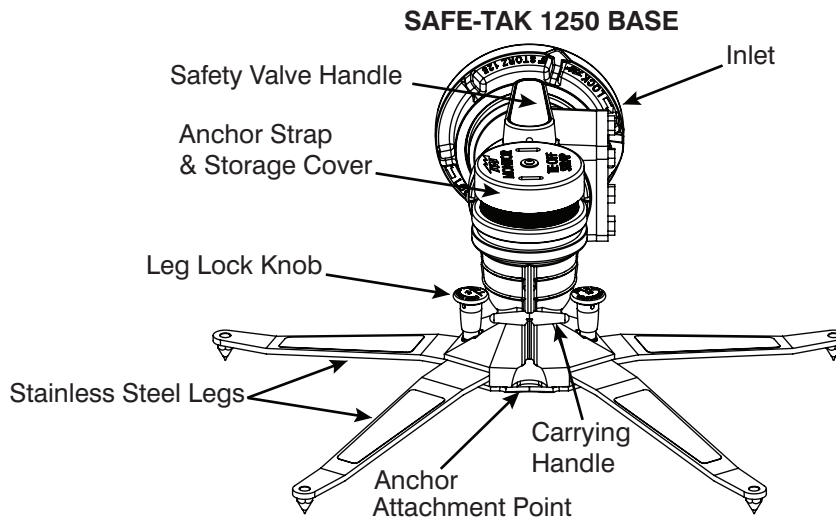
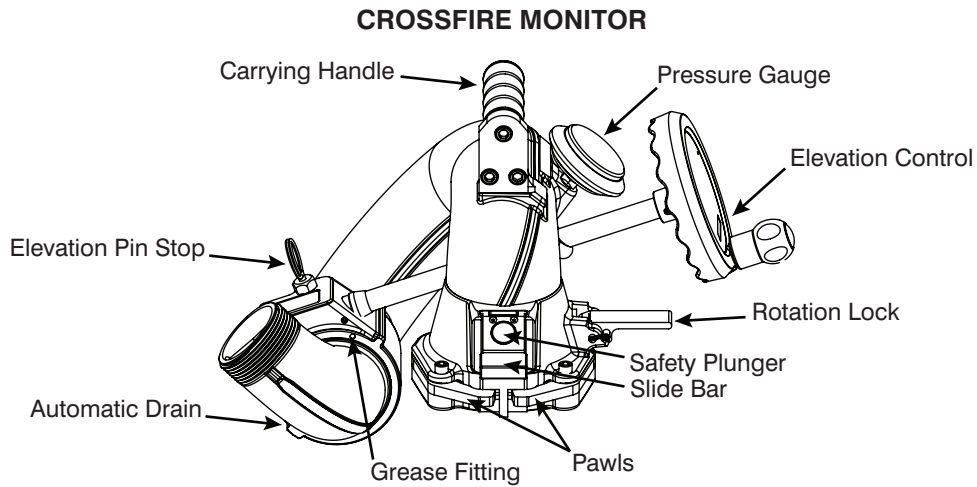

Truck Mount Adaptor Flange Mount Adaptor Companion Flange

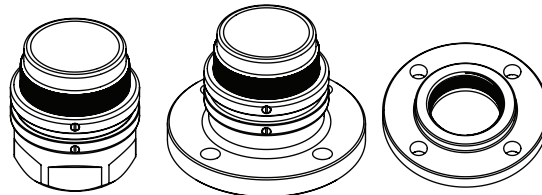

Figure 3.1

3.2 SPECIFICATIONS

	CROSSFIRE Monitor	SAFE-TAK 1250 Base
Weight	17 lbs (6.7 kg)	24 lbs (10.9 kg)
Storage Volume	4060 in ³ (.066m ³)	1620 in ³ (.027m ³)
Dimensions	20 x 14-1/2 x 14 in (508 x 368 x 355mm)	20 x 9 x 9 in (508 x 228 x 228mm)
Height Above Truck Flange	12-1/2 in (320mm)	N/A
Height Above Truck Deck (min)	14 in (360mm)	N/A
Height Above Ground on Base	16-1/2 in (420mm)	N/A
Line of Reaction Force Above Ground	4 in (100mm)	N/A
Flow Area (min)	8.3 in ² (5360mm ²)	
Operating Temperature of Fluid	33 to 120°F (1 to 50°C)	
Storage Temperature Range	-40 to 150°F (-40 to 65°C)	
Available Inlets	Single	Single and Double 2-1/2 in to 6 in
Materials Used	Aluminum 6000 series hard anodized MIL8625 class 3 type 2, stainless steel 300 series	

Table 3.2

3.3 USE WITH SALT WATER

Use with salt water is permissible provided the equipment is thoroughly cleaned with fresh water after each use. The service life of the equipment may be shortened due to the effects of corrosion, and is not covered under warranty.

3.4 OPERATING ENVELOPE



Damage or injury could result from operating the monitor beyond the safe operating envelope. Do not operate the monitor outside the envelope in the following graph(s).

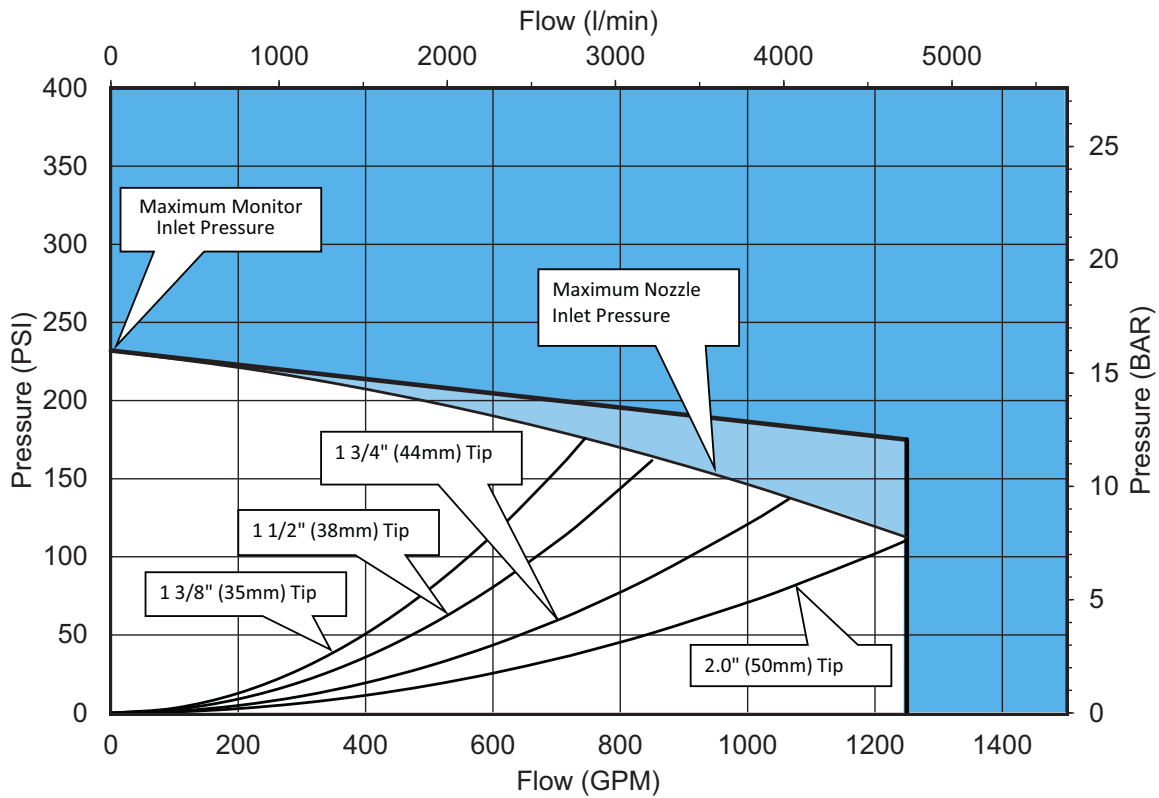

Figure 3.4

4.0 OPERATING INSTRUCTIONS

The CROSSFIRE monitor can be used on either a truck mounted flange or portable base. Installation on either base makes use of a quick connect swivel joint. The use of each base and the quick connect joint is explained in the following sections.

4.1 QUICK CONNECT SWIVEL JOINT

Two pawls, actuated by the slide bar, engage in the base swivel to make the quick connect joint. A safety plunger engages in the slide bar to prevent accidental unlocking of the slide bar when the monitor is under pressure.

4.2 INSTALLING THE MONITOR TOP ON THE BASE

To install the monitor on either the truck mount flange or portable base:

1. Turn elevation handwheel to make sure the elevation of the nozzle is above the 35° safety stop. Verify that the elevation stop pin is down and engaged.
2. Make sure the slide bar is in the up position.
3. Holding the monitor by the top carrying handle, position monitor over base and slide straight down.
4. Push the slide bar down and watch the pawls engage the groove in the base and the safety plunger engage in the hole in the slide bar.

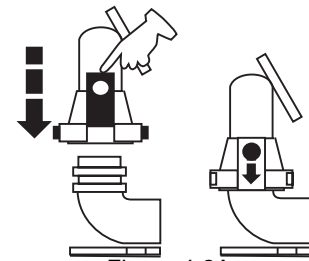
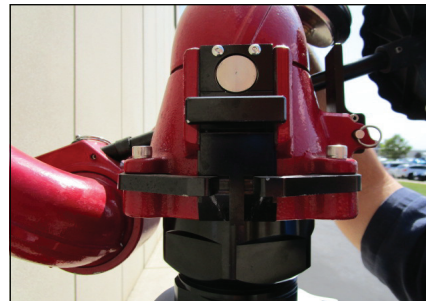

Figure 4.2A



Slide Bar in the UP position.
Plunger and pawls UNLOCKED.



Hold monitor over base and lower straight down.
Push Slide Bar DOWN to engage the
plunger and pawls.

Figure 4.2B

4.3 REMOVING THE MONITOR TOP FROM THE BASE

To remove the monitor top from the truck mount flange or portable base:

1. Stop all water flow to the monitor.
2. Depress the safety plunger to disengage the spring-loaded pawls from the groove in the base.
3. Holding the monitor by the top carrying handle, lift the monitor straight up off the base.

4.4 POSITIONING THE STREAM

4.4.1 HORIZONTAL ROTATION AND LOCK

The monitor can be rotated horizontally on the base to a desired position. The rotational position of the monitor must be locked before flowing water. When not rotating the monitor on the base, keep the rotation locked.

To position the monitor horizontally:

1. With the monitor on the base, rotate the monitor to a desired position.
2. Lock the rotational position by moving the rotation lock lever to the down position.
3. Manually unlock the rotational lock by moving the rotation lock lever to the up position before repositioning or removing the monitor from the base. A small spring holds the lever in the up (unlocked) position.



UNLOCKED

LOCKED

Figure 4.4.1



To avoid a sliding monitor, when used on a portable base, keep the horizontal angle between the water stream and the anchor strap as small as possible. At large angles, the base can slide in an arc around the anchor point which can result in injury or death if struck by the monitor or water stream.

4.4.2 ELEVATION CONTROL AND STOP PIN

⚠ DANGER

Low nozzle elevation angles can cause portable monitors to slide or lift off the ground which can result in injury or death from an out of control monitor. Do not operate the monitor below the elevation safety stop while on the portable base.

The handwheel controls nozzle elevation.

- Clockwise rotation of the wheel will raise the nozzle.
- Counter-clockwise rotation of the wheel will lower the nozzle.

When mounted on a truck base, the nozzle may be lowered below the 35° safety stop by pulling out the stop pin and rotating the handwheel below the 35° stop. When the nozzle is raised back above 35°, the spring loaded stop pin snaps back into position, automatically limiting the elevation of the nozzle with respect to the base to 35°.

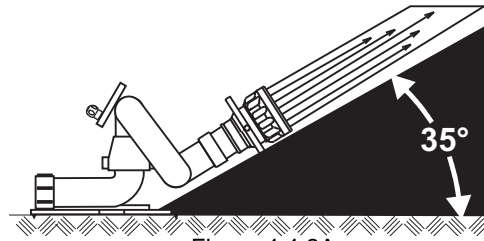

Figure 4.4.2A



Elevation Control Handwheel



Elevation Stop Pin Out



Elevation Stop Pin In



Elevation Stop Pin Safety Label

Figure 4.4.2B

4.5 AUTOMATIC DRAIN

An automatic drain is included to empty water from a low point in the monitor piping to prevent freezing and help empty hose lines. The valve is designed to close automatically when pressure in the monitor exceeds approximately 5 psi, and open again when the pressure drops to that point.

The automatic drain may be disabled if not desired for your application.

To disable the drain valve:

1. Unscrew the drain assembly and remove the screw and washer.
2. Flip over the rubber drain valve so the raised edge is against the face of the housing.
3. Reassemble the screw and washer and reinstall the drain valve assembly.

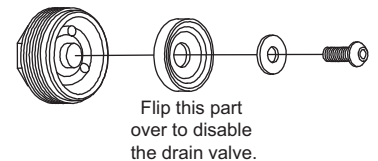

Figure 4.5

4.6 TRUCK MOUNT BASE

The CROSSFIRE monitor may be used from a truck by using a truck mount adapter. The truck mount adapter can be bolted to a three inch riser pipe with a three inch 150 lb. ASA companion flange and gasket, using four 5/8" bolts. It can also be screwed directly on a 3" NPT thread. Use of pipe thread sealant is recommended. The riser must be supported to safely withstand a nozzle reaction force of up to 900 lbs. Prior to installation, ensure that no interference exists between the monitor and other deck mounted equipment in any direction. A drain valve should be provided in the riser pipe which supplies the monitor. The riser should be drained immediately after each use during cold weather to prevent freezing and possible damage. The monitor has an automatic drain. If this drain has been disabled, the monitor must be drained by lowering the nozzle below horizontal. Installation instructions are supplied with the truck mount base.

4.7 TRUCK MOUNTING OF THE PORTABLE BASE

In some cases, a user may not have a riser directly off of the pump that can be used for mounting the monitor. In this case it may be desirable to supply the monitor with hose lines connected to the side discharge of the pumper. In these circumstances, it is recommended that the user purchase a Deck Mount Plate XF400-KIT from TFT. Please call 1-800-348-2686 for further information and advice concerning mounting alternatives. Installation instructions are shipped with this accessory.

⚠ WARNING

The Portable Monitor Storage Bracket is designed only to store the Portable Monitor Base. Attempting to flow from the storage bracket can cause the monitor to become dislodged from the bracket and out of control, causing severe injury or death. Always properly deploy the monitor before flowing.

4.8 FLOW CHARACTERISTICS

4.8.1 STACKED TIPS

NOZZLE DIAMETER	NOZZLE PRESSURE									
	50 PSI		80 PSI		100 PSI		150 PSI		175 PSI	
	FLOW (GPM)	REACTION (LBS)	FLOW (GPM)	REACTION (LBS)	FLOW (GPM)	REACTION (LBS)	FLOW (GPM)	REACTION (LBS)	FLOW (GPM)	REACTION (LBS)
1-3/8"	400	150	500	240	560	300	680	440	730	520
1-1/2"	470	180	600	280	660	350	810	520	870	620
1-3/4"	640	240	810	380	910	480	1100	712	1190	840
2.00"	840	310	1060	500	1190	630	---	---	---	---

Flow exceeds rating of truck mounted monitor.

NOZZLE DIAMETER (mm)	NOZZLE PRESSURE									
	3.5 BAR		5.5 BAR		7 BAR		10 BAR		12 BAR	
	FLOW (L/min)	REACTION (KG)	FLOW (L/min)	REACTION (KG)	FLOW (L/min)	REACTION (KG)	FLOW (L/min)	REACTION (KG)	FLOW (L/min)	REACTION (KG)
35	1500	70	1900	110	2200	140	2600	200	2800	240
38	1800	80	2300	130	2500	160	3000	230	3300	280
44	2400	110	3000	170	3400	220	4100	310	4500	370
50	3100	140	3900	220	4400	280	---	---	---	---

Flow exceeds rating of truck mounted monitor.

Table 4.8.1

4.8.2 AUTOMATIC MASTER STREAM NOZZLES

Automatic nozzles maintain a constant pressure by adjusting their opening to match the available flow. Consult the nozzle manufacturer for maximum flow and pressure ratings. In all cases, do not exceed the operating envelope.

4.8.3 STREAM STRAIGHTENERS

Because the water must make many bends while passing through a monitor, stream quality of smooth bore nozzles is improved with a stream straightener.

Do not use a stream straightener after a VORTEX nozzle as the stream straightener negates the vortex pattern.

4.8.4 PRESSURE LOSS

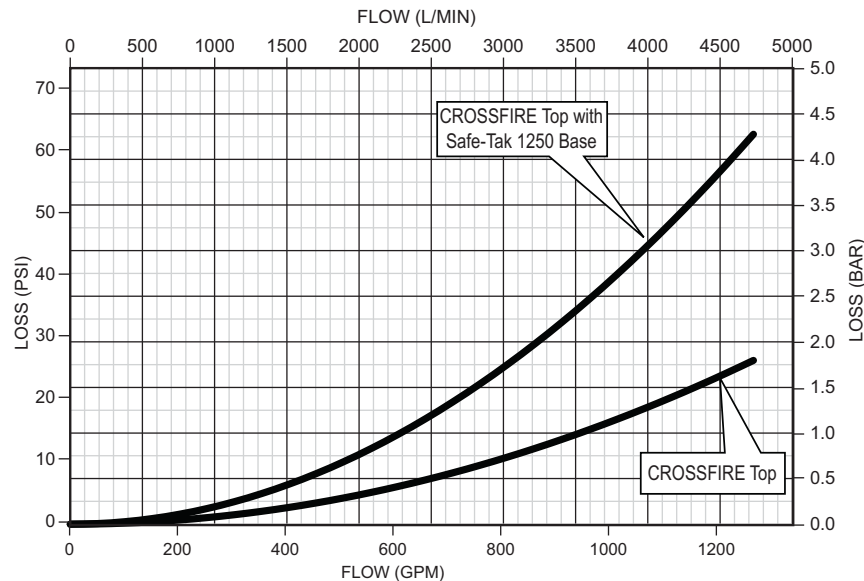

Figure 4.8.4

4.9 TRANSPORTING MONITOR ON THE TRUCK MOUNT BASE

If the monitor is to be transported on a truck mount base, the horizontal lock should be kept locked to keep the monitor from spinning on its base. The rotational position can be locked by moving the rotation lock lever to its down position. The nozzle may be supported by a bracket or pointed straight up.

5.0 SAFE-TAK 1250 BASE

The portable base allows the monitor to be positioned in places that are not accessible with a fire truck. As an added measure of safety, the SAFE-TAK 1250 portable base has a safety valve. The safety valve is to quickly reduce flow should the monitor and portable base ever leave the ground for any reason. [See section 5.6](#) for safety valve operation.

5.1 SITE SELECTION

Safe operation of the monitor on the portable base begins with site selection. The site should be a safe distance from the fire yet within reach of the nozzle stream. Select a flat even surface within 8 feet of a sturdy stationary object that can be used as an attachment point for the anchor strap. Set up the portable base with the anchor point between the portable base and desired target of the nozzle stream.

On ground, such as sand, mud, or gravel, wash out under the paddle may cause unwanted tripping of the safety valve on the SAFE-TAK 1250 portable base. In such a case, a thin flat object, such as a clipboard, may be placed under the paddle. Object under paddle must not keep any leg spike from contacting ground.

5.2 EXTENDING PORTABLE BASE LEGS

The portable base legs are extended by following these steps:

1. Hold the base carrying handle with one hand and grasp the end of one of the longer legs with the other hand.
2. Pull this leg away from the base forward in an arc, until the locking pin engages. The locking pin is spring loaded and automatically engages when the legs are in the correct position. Watch the leg lock knob drop down even with the lower band on the base, indicated by an arrow.
3. Repeat steps 1 & 2 for the other set of legs.
4. Set portable base on even ground with all leg spikes in contact with the ground.
5. Lift the storage cap to remove the anchor strap stored inside the base. Keep the strap near the monitor as it will be used to tie off the monitor before use.

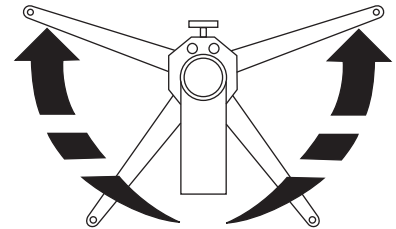

Grasp and pull up on the longer leg until the lock engages.



Repeat for the second set of legs.



Place the base on the ground with all spikes making contact. Remove the cap and anchor strap for later use.

Figure 5.2



In the unfolded position, the legs provide a stable base for operation of the monitor. Lack of stability can cause an out of control monitor resulting in injury or death. Do not operate as a portable monitor with one or both legs in the folded position.

5.3 RETRACTING PORTABLE BASE LEGS

To retract the legs for carrying or storage:

1. Pull up on one of the spring loaded leg lock knobs to disengage.
2. Grasp the forward leg on the same side as the knob and push it in an arc, towards the rear of the unit. The leg lock knob may be released as soon as the front leg begins to move out of position.
3. Continue to push until both legs come in contact with the rear stop.
4. Repeat steps 1, 2, & 3 for the other set of legs.

5.4 CARBIDE SPIKES

The Safe-Tak 1250 Portable Monitor has (5 or 6) tungsten carbide tipped spikes on the legs and the base to resist sliding by digging into the surface the monitor is sitting on. The amount of sliding force these spikes can withstand depends upon the amount of downward and sideways force that is on the base and the hardness and texture of the surface the spikes are in contact with. At low elevation angles, it is difficult for these spikes to resist sliding. These spikes are essential to safe operation of the monitor and must be in contact with the ground at all times. Set the monitor on an even surface so that all spikes contact the ground. Replace any spike if the tip diameter exceeds 1/16 inch (1.6mm).

WARNING

For stable operation all spikes must maintain contact with the ground. Lack of stability can cause an out of control monitor resulting in injury or death. Do not place the monitor on top of debris, objects, or uneven terrain that could keep any of the spikes from contacting the ground.

WARNING

On hard slippery surfaces the spikes may provide little resistance to sliding. A sliding monitor may become out of control and may cause injury or death.

To help increase resistance to sliding:

- Tie off the monitor
- Hook the legs on a stationary object
- Apply a person's weight to the monitor
- Replace any spike if the tip diameter exceeds 1/16 inch (1.6 mm)

CAUTION

Spikes are sharp and exposed. Use care around spikes to avoid injury and damage to clothing or other property.

5.5 ANCHORING BY USING THE TIE DOWN STRAP

The safest method of restraining the monitor is to use a tie down strap. It is inherently more reliable than other methods since it does not rely on traction or digging in of the spikes. It is also the safest method because even if the monitor slides its travel is limited by the strap length. A forward attachment point and a strap are provided with the Crossfire. A loop on the end of the strap may be placed over the anchor point or the strap may be wrapped around an object, such as a tree, and the snap end of the strap passed through the loop and pulled tight. Keep the entire length of the strap as close to the ground as possible. Snap the hook into the hole in the front of the Crossfire. Keep the distance between the monitor and anchor as short as possible.

If the strap is too short to reach a suitable anchor, it may be extended with strong rope or chain. Keep the distance between the monitor and anchor as short as possible. Remove all slack between the monitor and anchor before flowing water.

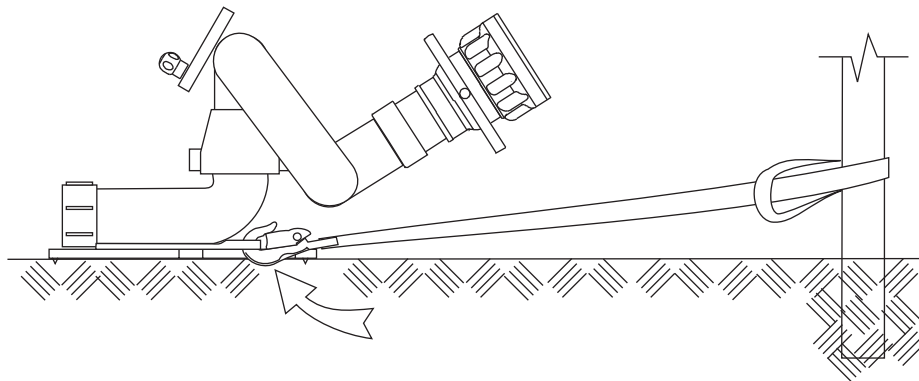

Figure 5.5

WARNING

Personnel in the path of an out of control monitor have and increase risk of injury or death. Securely tying the monitor off to an immovable object can limit the monitor travel in the event of an out of control monitor. Always tie off the monitor when it is in use. Remove all slack between the anchor and monitor before flowing water.

At low nozzle elevation angles the base may also require additional anchoring. The ability of a single anchor to stop sliding is a function of the horizontal angle between the strap and water stream. When the stream is in line with the anchor any sliding will be arrested by the anchor. As the horizontal angle increases between the anchor strap and the stream, the base can begin to slide in an arc around the anchor point. In this situation multiple anchor points may be required.

The strap should be stored inside the monitor base when not in use. The black rubber cap on the strap will hold the strap in the base and protect the sealing surface of the quick connect swivel joint.

5.6 PORTABLE BASE SAFETY VALVE

⚠ DANGER

Disconnecting, overriding, or tampering with this safety device may result in an out of control monitor causing severe injury or death. Do not alter the safety valve in any way.

⚠ WARNING

While the safety valve reduces flow to the monitor, the remaining flow is still capable of causing damage and/or injury. Exercise caution around monitor when valve is tripped or being reset. Always be sure to anchor monitor.

The portable base safety valve reduces the flow area through the monitor by 90%, should the base lose contact with the ground for any reason. In the reduced flow condition, the nozzle reaction force is less and reduces the risk of injury.

The safety valve is spring loaded in the closed position and must be manually set each time the monitor base is deployed or re-located. To set the safety valve:

1. Rotate the valve handle counter-clockwise until it locks into position, with the handle pointing straight back.

If the safety valve trips:

1. Shut off the flow of water.
2. Determine and correct the cause of trip before resetting safety valve.
3. Rotate the valve handle counter-clockwise until it locks into position, with the handle pointing straight back.
4. Restart water flow.



Safety Valve Tripped
(Flow Restricted)



Safety valve Open
(Full Flow Achieved)

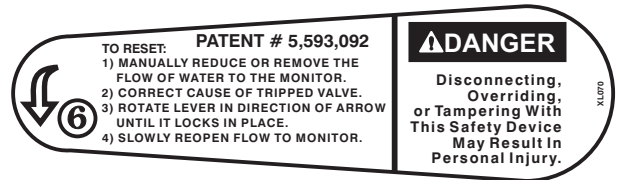

Portable Base Safety Reset Instruction Label

Figure 5.6

NOTICE

The safety valve responds only to vertical movement of the monitor. To prevent sliding, the monitor must be properly anchored, even with the safety valve option.

5.7 HOSE CONNECTION

Make the hose connection(s) to the portable base and extend the hose(s) straight back from the portable base at least 10 feet (3 meters). If only one inlet of a double inlet base will be used, a clapper valve will automatically close off the other inlet. Use caution when turning on the water supply to the monitor on the portable base. As the hose fills, it will become stiff and may cause the monitor and portable base to slide or tip or both. Open the pumper valve to the monitor slowly.

5.8 PRESSURE RELIEF OPTION

The optional pressure relief valve on the single inlet portable base can be adjusted to open between 90 and 300 psi. The pressure relief valve, TFT part A1809, is set at the factory to open at 150 psi. To change the relief pressure refer to the label on the bottom side of the pressure relief valve. A pressure relief valve can be added to the single inlet portable base by removing the cover on the side of the base. For additional information call 800-348-2686.

5.8.1 PRESSURE RELIEF VALVE SETTING

To set the relief valve pressure turn the adjusting screw on the relief valve housing until the surface of the screw is even with the desired pressure. Do not cap or plug discharge opening.

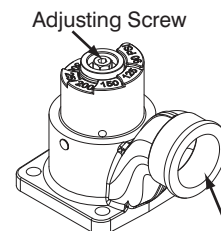

Relief Valve Discharge Opening
Figure 5.8.1

6.0 WARRANTY

Task Force Tips LLC, 3701 Innovation Way, Valparaiso, Indiana 46383-9327 USA ("TFT") warrants to the original purchaser of its products ("equipment"), and to anyone to whom it is transferred, that the equipment shall be free from defects in material and workmanship during the five (5) year period from the date of purchase for mechanical components, and the two (2) year period from the date of purchase for electrical components. TFT's obligation under this warranty is specifically limited to replacing or repairing the equipment (or its parts) which are shown by TFT's examination to be in a defective condition attributable to TFT. To qualify for this limited warranty, the claimant must return the equipment to TFT, at 3701 Innovation Way, Valparaiso, Indiana 46383-9327 USA, within a reasonable time after discovery of the defect. TFT will examine the equipment. If TFT determines that there is a defect attributable to it, TFT will correct the problem within a reasonable time. If the equipment is covered by this limited warranty, TFT will assume the expenses of repair.

If any defect attributable to TFT under this limited warranty cannot be reasonably cured by repair or replacement, TFT may elect to refund the purchase price of the equipment, less reasonable depreciation, in complete discharge of its obligations under this limited warranty. If TFT makes this election, claimant shall return the equipment to TFT free and clear of any liens and encumbrances.

This is a limited warranty. The original purchaser of the equipment, any person to whom it is transferred, and any person who is an intended or unintended beneficiary of the equipment, shall not be entitled to recover from TFT any consequential or incidental damages for injury to person and/or property resulting from any defective equipment manufactured or assembled by TFT.

It is agreed and understood that the price stated for the equipment is in part consideration for limiting TFT's liability. Some states do not allow the exclusion or limitation of incidental or consequential damages, so the above may not apply to you.

TFT shall have no obligation under this limited warranty if the equipment is, or has been, misused or neglected (including failure to provide reasonable maintenance) or if there have been accidents to the equipment or if it has been repaired or altered by someone else.

THIS IS A LIMITED EXPRESS WARRANTY ONLY. TFT EXPRESSLY DISCLAIMS WITH RESPECT TO THE EQUIPMENT ALL IMPLIED WARRANTIES OF MERCHANTABILITY AND ALL IMPLIED WARRANTIES OF FITNESS FOR A PARTICULAR PURPOSE. THERE IS NO WARRANTY OF ANY NATURE MADE BY TFT BEYOND THAT STATED IN THIS DOCUMENT.

This limited warranty gives you specific legal rights, and you may also have other rights which vary from state to state.

7.0 MAINTENANCE

TFT products are designed and manufactured to be damage resistant and require minimal maintenance. However, as the primary firefighting tool upon which your life depends, it should be treated accordingly. The unit should be kept clean and free of dirt by rinsing with water after each use. Any inoperable or damaged parts should be repaired or replaced before placing the unit in service. To help prevent mechanical damage, do not drop or throw equipment.

In applications where appliances are left continuously connected to the apparatus or other devices or are used where water is trapped inside the appliance, the appliance must be flushed with fresh water following each use and inspected for damage.

This appliance should be disconnected, cleaned and visually inspected inside and out at least quarterly, or as water quality and use may require. Moving parts such as handles, valve ball and couplings should be checked for smooth and free operation. Seals shall be greased as needed with Silicone based grease such as Molykote 112. Any scrapes that expose bare aluminum should be cleaned and touched up with enamel paint such as Rust-Oleum. Replace any missing or damaged parts before returning to service.

Any equipment taken out of service due to failure should be returned to the factory for repair or replacement. If you have any questions regarding the testing or maintenance of your valve, please call Task Force Tips at 800-348-2686.

Specific areas to check include:

Truck Mount Base:

1. Sealing surface above the swivel joint must be smooth.
2. Swivel joint must rotate freely.

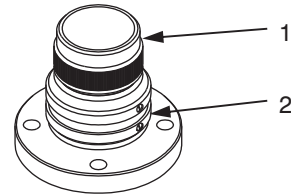

Portable Base:

1. Sealing surface above the swivel joint must be smooth.
2. Swivel joint must rotate freely.
3. Safety valve and Trip Paddle must move freely
4. Legs and leg lock pins must move freely and lock into position.
5. Leg spikes must be sharp. Replace if flats at the tip exceeds 1/16" diameter.

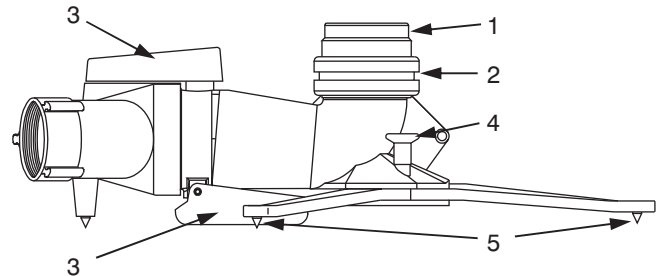

Monitor:

1. Handwheel must rotate freely.
2. Elevation stop pin must return to safe position
3. Quick Disconnect Latch and Safety Catch must operate freely.
4. Rotation Lock must operate freely and keep monitor from rotating when engaged.

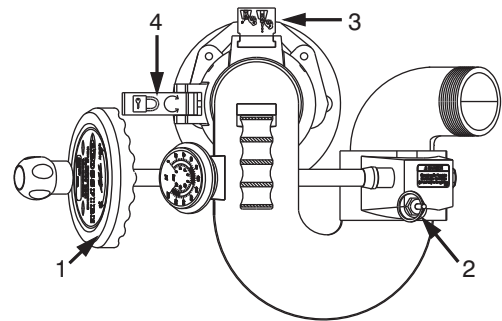

7.1 GREASING THE WORM GEAR

Turn the handwheel to move the nozzle to its highest elevation and pump grease (medium viscosity automotive) into the fitting in the worm gear housing until excess appears.

7.2 SERVICE TESTING

In accordance with NFPA 1962, equipment must be tested a minimum of annually. Units failing any part of this test must be removed from service, repaired and retested upon completion of the repair.

7.3 REPAIR

Factory service is available. Factory serviced equipment is repaired by experienced technicians, wet tested to original specifications, and promptly returned. Call TFT service department at 1-800-348-2686 to troubleshoot and, if needed, directions for return. A return for service form can also be obtained at tft.com/Support/Returning-an-Item-for-Service.

Repair parts and service procedures are available for those wishing to perform their own repairs. Task Force Tips assumes no liability for damage to equipment or injury to personnel that is a result of user service. Contact the factory or visit the web site at tft.com for parts lists, exploded views, test procedures and troubleshooting guides.

Performance tests shall be conducted on the equipment after a repair, or anytime a problem is reported to verify operation in accordance with TFT test procedures. Consult factory for the procedure that corresponds to the model and serial number of the equipment. Any equipment which fails the related test criteria should be removed from service immediately. Troubleshooting guides are available with each test procedure or equipment can be returned to the factory for service and testing.



It is the responsibility of service technicians to ensure the use of appropriate protective clothing and equipment. The chosen protective clothing and equipment must provide protection from potential hazards users may encounter while servicing equipment. Requirements for protective clothing and equipment are determined by the Authority Having Jurisdiction (AHJ).



Any alterations to the product or its markings could diminish safety and constitutes a misuse of this product.



All replacement parts must be obtained from the manufacturer to assure proper performance and operation of the device.

8.0 EXPLODED VIEW AND PARTS LISTS

Exploded views and parts lists are available at tft.com/serial-number.

9.0 OPERATION AND INSPECTION CHECKLIST

BEFORE BEING PLACED BACK IN SERVICE, appliances must be inspected to this list:

1. All valves open and close smoothly and fully.
2. The waterway is clear of obstructions.
3. There is no damage to any thread or other type connection.
4. The pressure setting of the relief valve, if any, is set correctly.
5. All locks and hold-down devices work properly.
6. Internal gaskets are in accordance with NFPA 1962.
7. There is no damage to the appliance (e.g., dents, cracks, corrosion, or other defects that could impair operation).
8. All swiveling connections rotate freely.
9. There are no missing parts or components.
10. The marking for maximum operating pressure is visible.
11. There are no missing, broken, or worn lugs on couplings.

Monitor must be inspected for proper operation and function according to this checklist before each use.

- 1** • There is no damage to the appliance that could impair safe operation (e.g. dents, cracks, corrosion, missing, broken or loose parts, damaged markings, or other defects)
 • Waterway is clear of obstructions
 • Gaskets are in good repair
 • Hose and nozzle are securely attached.
 • All valves open and close fully and smoothly (if so equipped)
 • The pressure setting on the relief valve (if so equipped) is set correctly

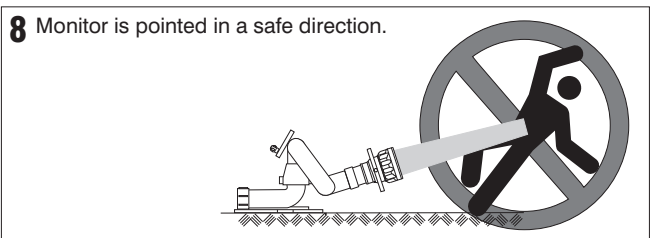
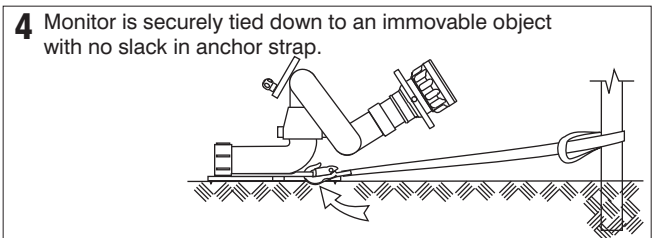
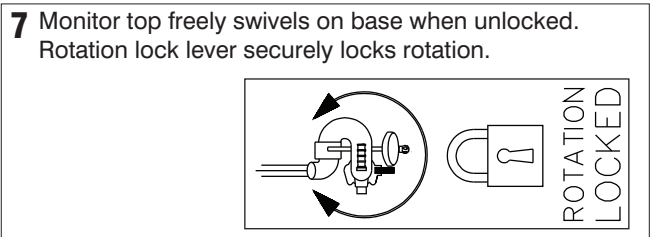
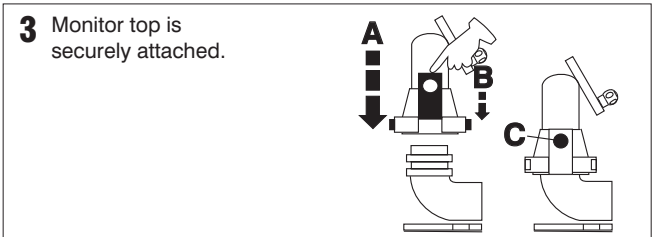
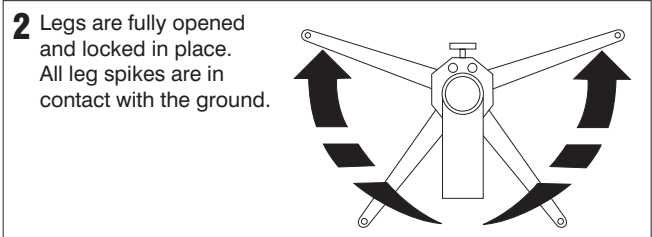
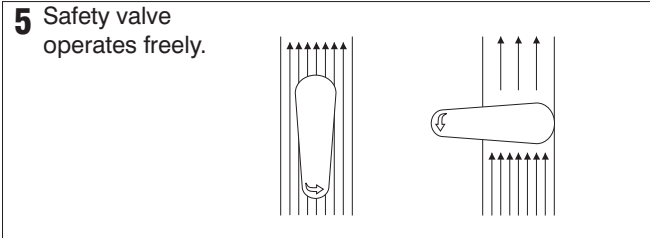

Equipment failing any part of the checklist is unsafe for use and must have the problem corrected before use or being placed back into service. Operating equipment that has failed the checklist is a misuse of this equipment.

TASK FORCE TIPS LLC
 MADE IN USA · tft.com

3701 Innovation Way, Valparaiso, IN 46383-9327 USA
 800-348-2686 · 219-462-6161 · Fax 219-464-7155