



# EDUCTOR 350 SERIES IN-LINE

## INSTRUCTION FOR INSTALLATION, OPERATION, AND MAINTENANCE

**⚠ DANGER**

Understand manual before use. Operation of this device without understanding the manual and receiving proper training is a misuse of this equipment. Obtain safety information at [tft.com/serial-number](http://tft.com/serial-number).

This equipment is intended for use by trained and qualified emergency services personnel for firefighting. All personnel using this equipment shall have completed a course of education approved by the Authority Having Jurisdiction (AHJ).

This instruction manual is intended to familiarize firefighters and maintenance personnel with the operation, servicing, and safety procedures associated with this product. This manual should be kept available to all operating and maintenance personnel.

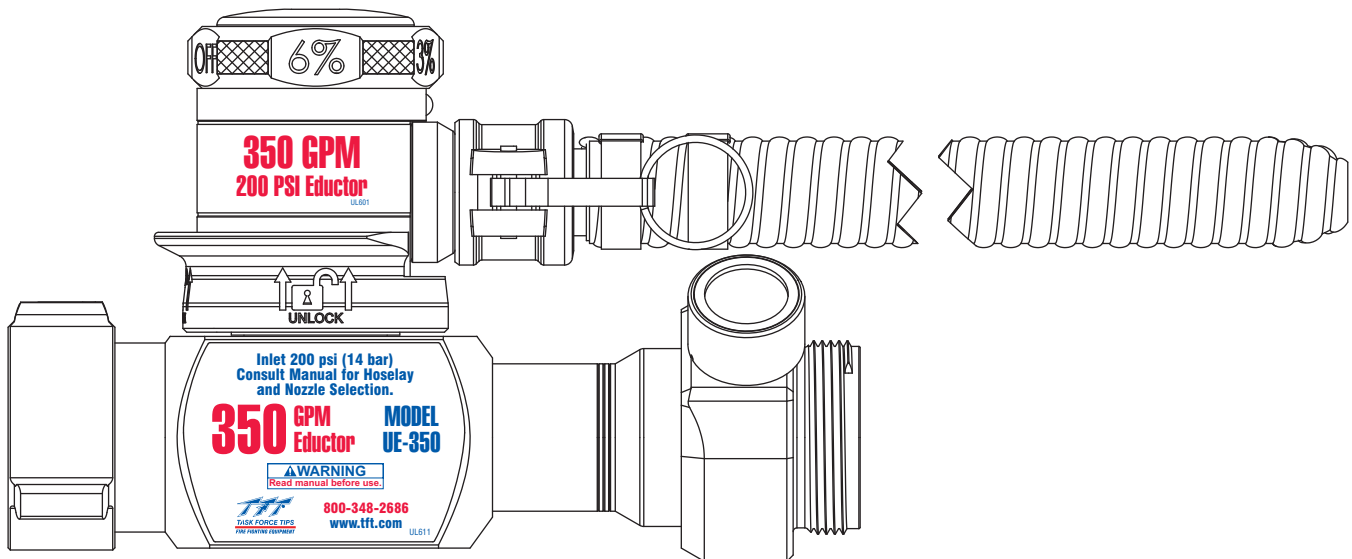

**TASK FORCE TIPS LLC**  
MADE IN USA · [tft.com](http://tft.com)

3701 Innovation Way, Valparaiso, IN 46383-9327 USA  
800-348-2686 · 219-462-6161 · Fax 219-464-7155

# DANGER

## PERSONAL RESPONSIBILITY CODE

The member companies of FEMSA that provide emergency response equipment and services want responders to know and understand the following:

1. **Firefighting and Emergency Response are inherently dangerous activities requiring proper training in their hazards and the use of extreme caution at all times.**
2. **IT IS YOUR RESPONSIBILITY to read and understand any user's instructions, including purpose and limitations, provided with any piece of equipment you may be called on to use.**
3. **IT IS YOUR RESPONSIBILITY to know that you have been properly trained in Firefighting and/or Emergency Response and in the use, precautions, and care of any equipment you may be called upon to use.**
4. **IT IS YOUR RESPONSIBILITY to be in proper physical condition and to maintain the personal skill level required to operate any equipment you may be called upon to use.**
5. **IT IS YOUR RESPONSIBILITY to know that your equipment is in operable condition and has been maintained in accordance with the manufacturer's instructions.**
6. **Failure to follow these guidelines may result in death, burns or other severe injury.**

Fire and Emergency Manufacturers and Service Association, Inc.  
PO Box 147, Lynnfield, MA 01940 • www.FEMSA.org

© 2020 FEMSA. All Rights Reserved.



### SUPPORTING MATERIALS

The following documents contain supporting safety and operating information pertaining to the equipment described in this manual.

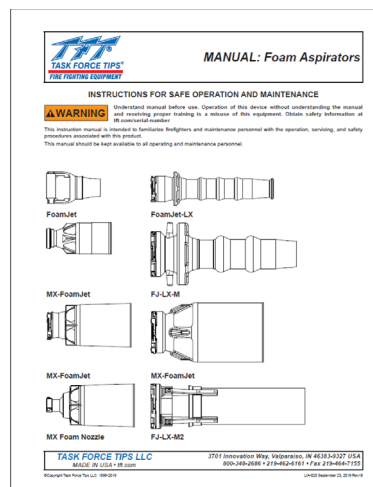





LIA-025 Foam Aspirator Manual

## TABLE OF CONTENTS







- 1.0 MEANING OF SAFETY SIGNAL WORDS
- 2.0 SAFETY
- 3.0 GENERAL INFORMATION
  - 3.1 USE WITH SALT WATER
  - 3.2 VARIOUS MODELS AND TERMS
- 4.0 INSTALLATION
- 5.0 OPERATING INSTRUCTIONS
  - 5.1 CLEANING INSTRUCTIONS
  - 5.2 CONCENTRATE INTAKE HOSE OPTIONS
- 6.0 USE WITH FOAM
  - 6.1 FOAM SELECTION
  - 6.2 FOAM ATTACHMENT OPTIONS
  - 6.3 FOAM CONSUMPTION
  - 6.4 FOAM SUPPLY LOGISTICS
- 7.0 MAXIMUM HOSE LAY
- 8.0 NOZZLE SELECTION
  - 8.1 NOZZLE COMPATIBILITY
- 9.0 WARRANTY
- 10.0 MAINTENANCE
  - 10.1 SERVICE TESTING
  - 10.2 REPAIR
- 11.0 TROUBLE SHOOTING
- 12.0 EXPLODED VIEWS AND PARTS LISTS
- 13.0 OPERATION AND INSPECTION CHECKLIST

## 1.0 MEANING OF SAFETY SIGNAL WORDS

A safety related message is identified by a safety alert symbol and a signal word to indicate the level of risk involved with a particular hazard. Per ANSI Z535.6, the definitions of the four signal words are as follows:

- |  |   |
|--|---|
|  | <b>DANGER</b> indicates a hazardous situation which, if not avoided, will result in death or serious injury.                |
|  | <b>WARNING</b> indicates a hazardous situation which, if not avoided, could result in death or serious injury.              |
|  | <b>CAUTION</b> indicates a potentially hazardous situation which, if not avoided, could result in minor or moderate injury. |
|  | <b>NOTICE</b> is used to address practices not related to physical injury.  |

## 2.0 SAFETY

- |   |   |
|---|---|
|   | Lack of foam can place operator at risk of injury or death. Establish foam flow and adequate supply of concentrate for the task before advancing into hazardous situations.   |
|   | This equipment is intended for use by trained personnel for firefighting. Use of this equipment for other purposes may involve hazards not addressed by this manual. Seek appropriate guidance and training to reduce risk of injury.   |
|   | Improper use of foam or using the wrong type of foam can result in illness, injury, or damage to the environment. Follow foam manufacturer's instructions and fire service training as directed by the AHJ.   |
|   | For Class B fires, lack of foam or interruption in the foam stream can cause a break in the foam blanket and greatly increase the risk of injury or death. Follow procedures established by the AHJ for the specific fuel and conditions.   |
|   | Equipment may be damaged if frozen while containing significant amounts of water. Such damage may be difficult to detect visually. Subsequent pressurization can lead to injury or death. Any time the equipment is subject to possible damage due to freezing, it must be tested and approved for use by qualified personnel before being considered safe for use. |
|  | To prevent mechanical damage, do not drop or throw equipment.   |

### 3.0 GENERAL INFORMATION

TFT's 350 Series Eductors can be used with 1/2% Class A foam concentrate for wildland, rural, and urban fire suppression on Class A fuels (wood, paper, combustible materials). Class A concentrates that have received USDA and USFS approval are recommended.

On class B materials, the eductors can be used with high viscosity 1%, 3%, 6%, 3x3%, and 3x6% Alcohol Resistant Class B concentrates.

The eductor can also be used with plain AFFF concentrates rated at 1%, 3% or 6% with various freeze protected foams, and with FFFP foam types. These foams generally have a lower viscosity than the calibration viscosity of the TFT eductor and will be inducted faster than expected resulting in stronger concentrations. While this does not degrade foam quality, it does reduce the operation time for a given foam supply. Testing should be done with the foam being used to assure accurate induction rate.

Standard inlet operating pressure is 200 psi on all TFT eductors (1400kPa/14 bar), except the low pressure versions marked for 150 psi (1000kPa/10 bar).

### 3.1 USE WITH SALT WATER

Consult foam manufacturer's documentation and training by the Authority Having Jurisdiction (AHJ) before mixing foam concentrate with salt water.

If the equipment is used with salt water, it must be thoroughly cleaned with fresh water after each use. The service life of the equipment may be shortened due to the effects of corrosion, and is not covered under warranty.

### 3.2 VARIOUS MODELS AND TERMS

TFT 350 Series Eductors are available in several flows and with a variety of inlet couplings. These must be specified at the time of order. Consult the factory for special thread requests.

The eductor can be split into two parts by grasping the locking ring and retracting it fully to separate the metering head from the eductor body. All the foam passageways can easily be inspected. The foam passageway into the eductor contains a free-floating check disk with three fins. The check disk is pressure activated to keep water from coming out of the fire hose and back into the foam pail.

The metering head contains a red backflush button that can be depressed to open the check disk.

The metering head also has a large proportioning knob that can be rotated to align the ball valve to different detent positions. The 2.5" eductors have five choices: Off, 1/2%, 1%, 3%, and 6%. Each foam setting has a precision sized metering orifice in the valve ball. The eductor cannot be operated between settings, as the metering orifices will not line up properly. The setting of the proportioning knob lines up with the white indicator ball.

**CAUTION** Intermixing metering heads and eductor bodies of different flow rates can cause incorrect foam strength, resulting in risk of injury as the ability to control the fire is compromised. Do not intermix metering heads with eductor bodies of different flow rates.

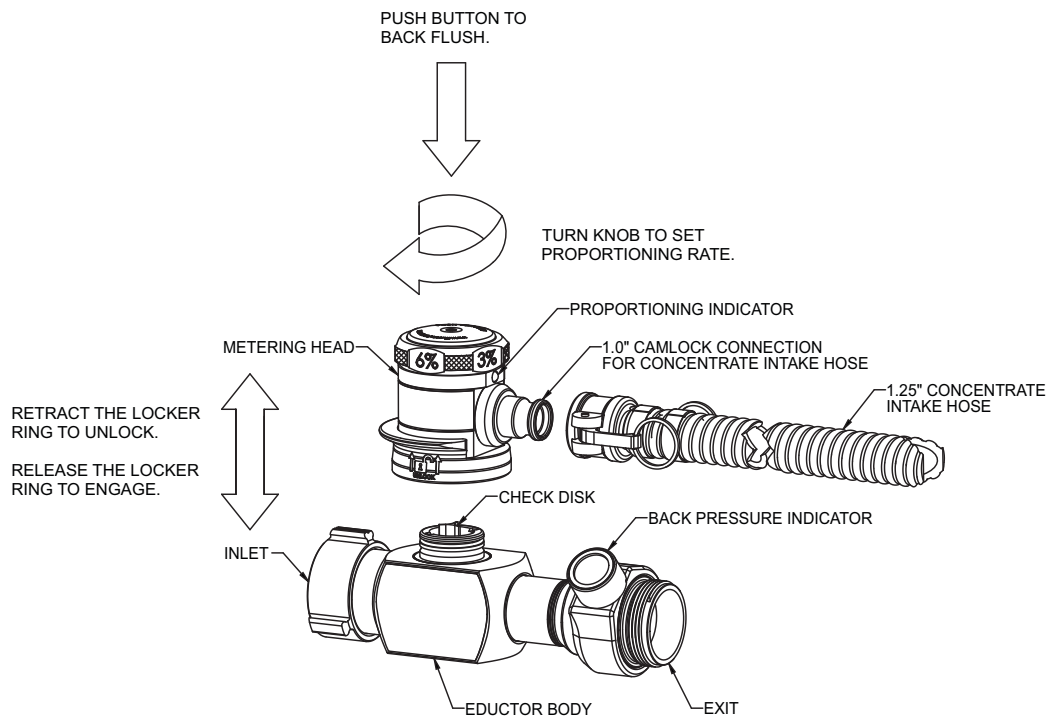

Figure 3.2

## 4.0 INSTALLATION

The eductor body is equipped with four 3/8-16 x 3/4" deep threaded mounting holes. To mount the unit, attach to the desired location using bolts with enough length to provide at least 1/2" engagement with the unit. See below for mounting hole spacing.

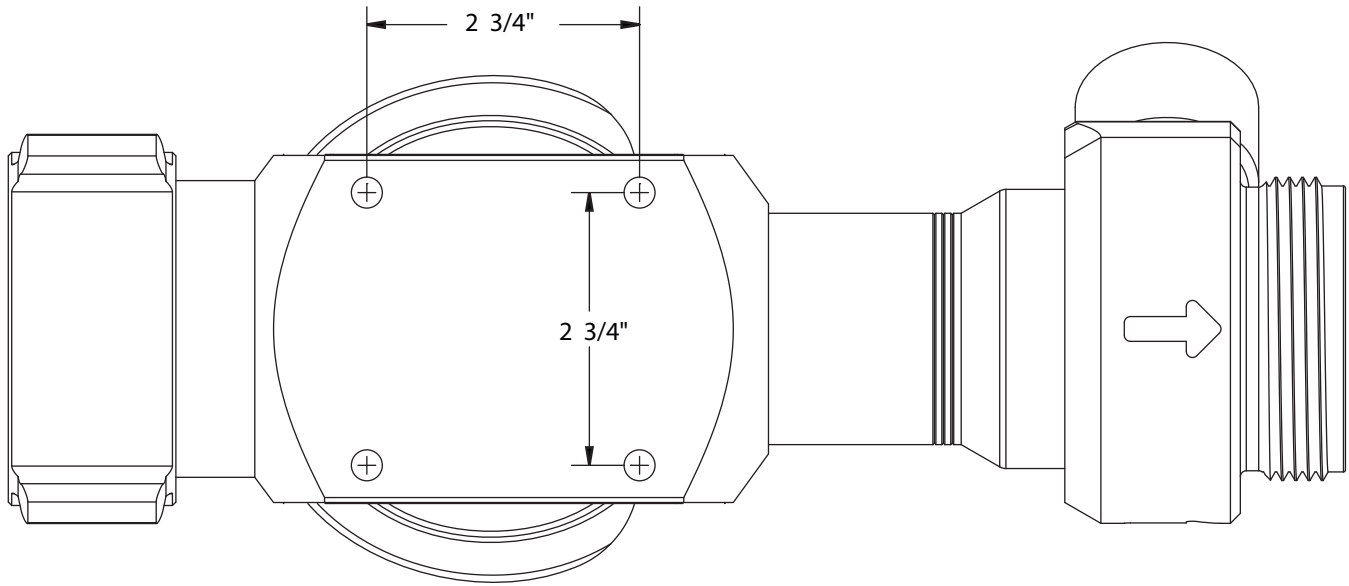

Figure 4.0

## 5.0 OPERATING INSTRUCTIONS

Refer to training approved by the AHJ for appropriate foam type, concentration, and hose length.

1. Choose the appropriate foam concentration.
2. Lay the appropriate hose line.
3. Connect the appropriate nozzle.
4. Charge the hose and open the nozzle fully to establish the water flow.
5. Adjust the pump pressure so the eductor inlet is set at pressure specified on body label.
6. Rotate the percentage knob to the desired concentration.
7. Place the concentrate intake hose in the foam supply.

### 5.1 CLEANING INSTRUCTIONS

The eductor must be cleaned after each use to prevent residual foam concentrate from clogging the passageways.

1. After use, take the concentrate intake hose out of the foam supply.
2. Turn down the pump pressure to below 75 psi (5.2 bar).
3. Shut off the nozzle.
4. Restrain the hose and expect a rapid discharge of water, especially at the 6% setting.
5. Push the red flush button to run fresh water through the hose and metering head on each setting until there is no visible foam in the flush water.
6. Retract the lock ring to remove the metering head.
7. Turn off water supply and remove the eductor from the hose so that any remaining foam residue can be washed from the wand, metering head and eductor.



**Rapid backflush discharge from the wand could cause injury.**

**The backflush push button is pressure activated and must not be forced at pressures over 75 psi (5 bar). Do not backflush above 75 psi.**

### 5.2 CONCENTRATE INTAKE HOSE OPTIONS

The eductor is shipped with a 1.25" x 8' clear, flexible hose with a 1.0" camlock connection. A 1.25" x 8' black, high UV resistant hose with a lower temperature rating is available for purchase. To order, call 800-348-2686 and ask for part # UE940.

A camlock adaptor is available for those who wish to use a hose with a 1.5" female camlock connection. To order, call 800-348-2686 and ask for part #UE960-KIT.

## 6.0 USE WITH FOAM

### 6.1 FOAM SELECTION

Actual foam concentrations vary with changes in water flow, foam concentrate temperature and viscosity. The user must verify that the concentrate's performance is suitable for use in their application. Refer to training approved by the AHJ regarding foam concentrate use. In all cases, the manufacturer's recommendations must be followed.



**Mixing of foam concentrates can cause the contents of the foam tank to gel and produce unpredictable results. To reduce the risk of injury due to unpredictable foam production:**

- Do not mix different types of foam concentrates or foams of the same type from different manufacturers.
- Clean tank and foam passages thoroughly when changing foam types.

### 6.2 FOAM ATTACHMENT OPTIONS

Expansion ratios vary depending on the type of nozzle used. Refer to training approved by the AHJ when choosing a foam nozzle or attachment.

**Medium Expansion Nozzle** — produces the greatest expansion ratios. It is generally used on Class B fuels for vapor suppression and Class A fuels when a longer lasting insulating layer of drier foam is desired.

**Low Expansion Nozzle** — can be used with either Class A or B foam solutions. Reach is slightly less than the smooth bore. It is generally used on Class B fires for extinguishment and Class A fuels to soak the fuel with a wet foam solution.

**Straight Stream Nozzle** — is for Class A foam solutions. Foam expansion will be negligible. For use where maximum reach or penetration is desired.

### 6.3 FOAM CONSUMPTION

The following tables indicate the theoretical foam concentrate flow rate and the time it will take to empty a 5 gallon container of various concentrates with eductors of different ratings.

**250 GPM Eductor**

Setting	Foam Class	Time to Empty 5 Gallons	Foam Flow Rate in GPM
1/2%	A	4 min	1.25
1%	B	2 min	2.5
3%	B	40 sec	7.5
6%	B	20 sec	15

**350 GPM Eductor**

Setting	Foam Class	Time to Empty 5 Gallons	Foam Flow Rate in GPM
1/2%	A	2 min 54 sec	1.75
1%	B	1 min 26 sec	3.5
3%	B	29 sec	10.5
6%	B	14 sec	21

**800 L/min Eductor**

Setting	Foam Class	Time to Empty 5 Gallons	Foam Flow Rate in L/min
1/2%	A	5 min	4
1%	B	2 min 30 sec	8
3%	B	50 sec	24
6%	B	25 sec	48

**1500 L/min Eductor**

Setting	Foam Class	Time to Empty 5 Gallons	Foam Flow Rate in L/min
1/2%	A	2 min 40 sec	7.5
1%	B	1 min 20 sec	15
3%	B	27 sec	45
6%	B	13 sec	90

**1000 L/min Eductor**

Setting	Foam Class	Time to Empty 5 Gallons	Foam Flow Rate in L/min
1/2%	A	4 min	5
1%	B	2 min	10
3%	B	40 sec	30
6%	B	20 sec	60

**Actual calibrated rate for each setting and the foam concentration used for calibration**

Setting	Actual Rate	Foam Class	UL-162 Tolerance
1/2%	0.58%	A	.5 - .65%
1%	1.15%	B	1 - 1.3%
3%	3.45%	B	3 - 3.9%
6%	6.50%	B	6 - 7.8%

The Class B foam used for calibration is the "Universal Gold 1%/3% Alcohol Resistant Aqueous Film Forming Foam (AR-AFFF)" from National Foam. The calibration viscosity is 2500 centipoise tested with Brookfield #4 Spindle @ 60 rpm The calibration hose length is 50ft.

## 6.4 FOAM SUPPLY LOGISTICS

**⚠ DANGER**

Lack of foam can place operator at risk of injury or death. To reduce the risk of injury due to lack of foam:

- Establish foam flow before advancing into hazardous situations.
- Keep an adequate supply of foam concentrate on hand.
- Check concentrate level periodically.

The foam suction hose is matched to the eductor and must not be lengthened. Lengthening the foam suction hose reduces foam flow, resulting in weak foam. Position foam buckets within reach of the standard length foam suction hose.

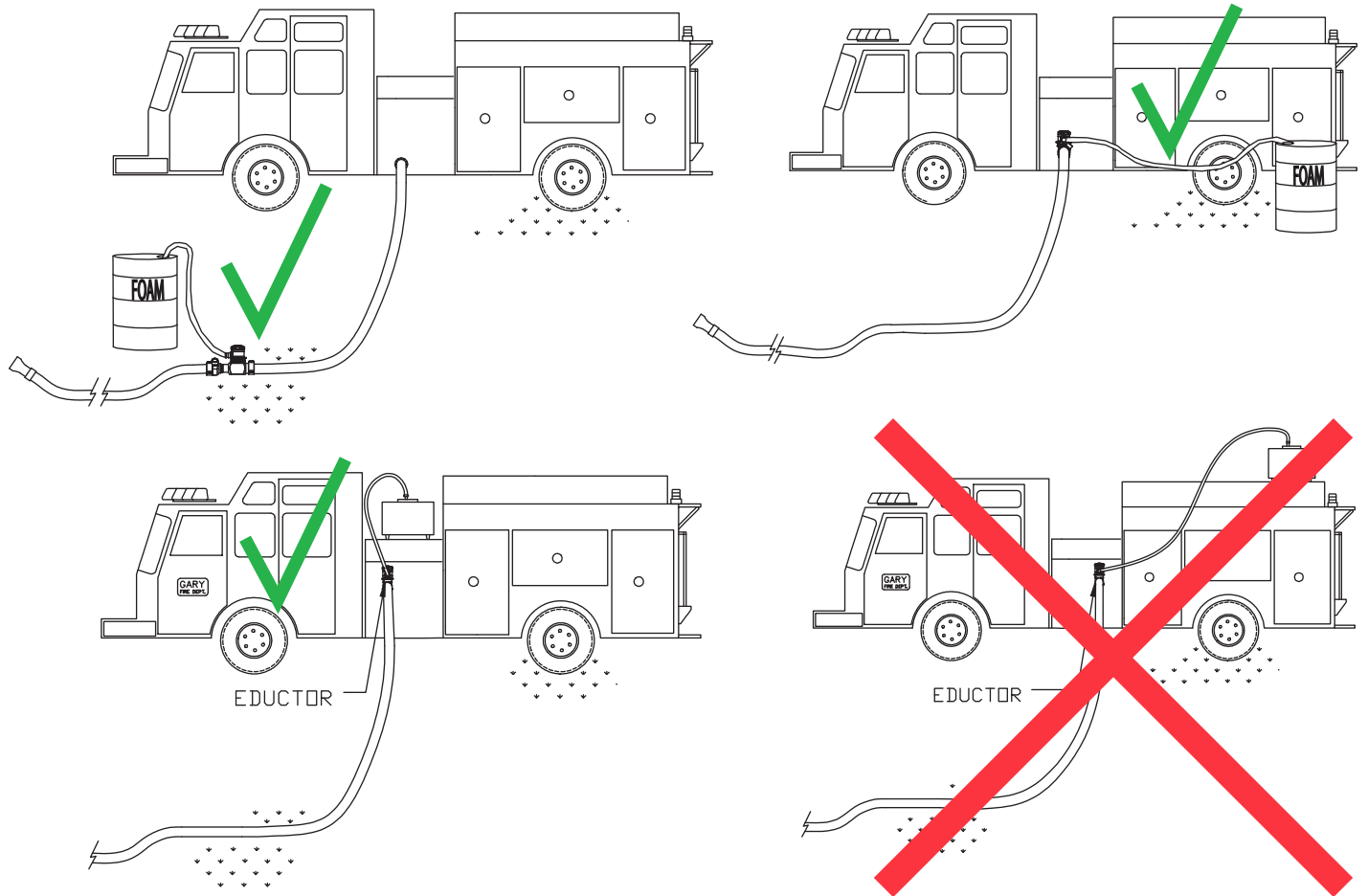

Figure 6.4



## 7.0 MAXIMUM HOSE LAY

The maximum hose lay is based on the back pressure. Pushing the foam solution through the hose and eductor causes back pressure on the eductor exit. If the back pressure on a 200 psi (14 bar) nozzle is over 130 psi (9 bar) the eductor will not work. If the back pressure on the 150 psi (10 bar) eductor is over 80 psi (5.5 bar), the eductor will not work.

Elevation loss adds to the back pressure when the nozzle is higher than the eductor. For each foot in vertical height, there is 0.4 psi elevation loss.



**Excess back pressure causes loss of foam flow resulting in risk of injury or death from an ineffective stream.**

- Verify that adequate foam flow is established and maintained.
- Do not exceed the maximum back pressure.

The eductor can be used with or without a monitor. The maximum hose lays and elevations change due to the different friction losses in the monitors. To use in a permanent installation with another monitor, calculate friction loss in pipes and elevation changes to determine correct setup.

To calculate back pressure, add the nozzle pressure, hose friction loss, monitor appliance loss if present, and elevation pressure loss together. The sum must not exceed 130 psi (9 bar) or 80 psi (5.5 bar) depending on the model. The Go/No-Go pressure gage on the outlet of the unit indicates acceptable back pressure levels. Should the gage show a pressure in the No-Go (red) range, shut down the line and change the line setup to lower the pressure.

## NOTICE

**Low pressure 150 psi (10 bar) eductors are compatible only with 55 psi (4 bar) nozzles.**

Friction loss varies with different brand hoses. Determine the friction loss of your own hose. The nominal flow of the eductor is the sum of the water plus the foam concentrate when set at 6%. The eductor should always have 200 psi (14 bar) at the inlet unless otherwise specified on the eductor body. The water flow does not change with different percentage settings; however the inducted concentrate will change when the percentage setting is changed. Therefore, the total flow exiting the eductor is lower at 1/2% than at 6%. Lower flow rate reduces nozzle pressure and hose friction loss. Longer hose can be used when proportioning rate is less because less work is needed to move less foam concentrate.

## 8.0 NOZZLE SELECTION

Eductors work with any nozzle whose gallonage is equal or greater than that of the eductor. If a nozzle with a larger gallonage is used, the reach of nozzle and the proportioning rate of the eductor will be compromised.

Non-aspirated automatic nozzles can produce expansion ratios of 6-8:1 when measured at the end of the stream. By maintaining a constant nozzle pressure, automatic nozzles keep the velocity of the stream high. Large amounts of air are pulled into the stream and mix with the foam concentrate/water solution as the stream leaves the nozzle.

Air-aspirating devices, such as the TFT FOAMJET, allow a wider selection of foam concentrates to be used, and can produce a better quality of finished foam. The final expansion ratio and, amount of finished foam, depends on the type of foam concentrate being used.



**Excess back pressure causes loss of foam flow resulting in risk of injury or death from an ineffective stream. Operate the nozzle fully open to prevent excessive back pressure.**

## 8.1 NOZZLE COMPATIBILITY

The following table lists the compatibility between eductors and nozzles.

350 SERIES EDUCTORS				
Nozzle Name	Nozzle Model #	Water Flow Setting GPM	Nozzle Pressure PSI	Multi-Expansion Foam Attachment
Max-Force	MD*2A	100-500	100 or 55	FJ-MX-MD
	MD-ERP-*2A			
	MD-ER-*2A			
Max-Matic	MD*8A	100-500	100 or 55	FJ-MX-MD
	MD-ERP-*8A			
	MD-ER-*8A			
	MD*7A		80	
Max-Flow	MD*4A	100-500	100 or 55	FJ-MX-MD
	MD-ERP-*4A			
	MD-ER-*4A			

Table 8.1

## 9.0 WARRANTY

Task Force Tips LLC, 3701 Innovation Way, Valparaiso, Indiana 46383-9327 USA (“TFT”) warrants to the original purchaser of its products (“equipment”), and to anyone to whom it is transferred, that the equipment shall be free from defects in material and workmanship during the five (5) year period from the date of purchase. TFT’s obligation under this warranty is specifically limited to replacing or repairing the equipment (or its parts) which are shown by TFT’s examination to be in a defective condition attributable to TFT. To qualify for this limited warranty, the claimant must return the equipment to TFT, at 3701 Innovation Way, Valparaiso, Indiana 46383-9327 USA, within a reasonable time after discovery of the defect. TFT will examine the equipment. If TFT determines that there is a defect attributable to it, TFT will correct the problem within a reasonable time. If the equipment is covered by this limited warranty, TFT will assume the expenses of repair.

If any defect attributable to TFT under this limited warranty cannot be reasonably cured by repair or replacement, TFT may elect to refund the purchase price of the equipment, less reasonable depreciation, in complete discharge of its obligations under this limited warranty. If TFT makes this election, claimant shall return the equipment to TFT free and clear of any liens and encumbrances.

This is a limited warranty. The original purchaser of the equipment, any person to whom it is transferred, and any person who is an intended or unintended beneficiary of the equipment, shall not be entitled to recover from TFT any consequential or incidental damages for injury to person and/or property resulting from any defective equipment manufactured or assembled by TFT.

It is agreed and understood that the price stated for the equipment is in part consideration for limiting TFT’s liability. Some states do not allow the exclusion or limitation of incidental or consequential damages, so the above may not apply to you.

TFT shall have no obligation under this limited warranty if the equipment is, or has been, misused or neglected (including failure to provide reasonable maintenance) or if there have been accidents to the equipment or if it has been repaired or altered by someone else.

**THIS IS A LIMITED EXPRESS WARRANTY ONLY. TFT EXPRESSLY DISCLAIMS WITH RESPECT TO THE EQUIPMENT ALL IMPLIED WARRANTIES OF MERCHANTABILITY AND ALL IMPLIED WARRANTIES OF FITNESS FOR A PARTICULAR PURPOSE. THERE IS NO WARRANTY OF ANY NATURE MADE BY TFT BEYOND THAT STATED IN THIS DOCUMENT.**

This limited warranty gives you specific legal rights, and you may also have other rights which vary from state to state.

## 10.0 MAINTENANCE

The eductor does not need regular maintenance. However, the eductor must be completely cleaned after each use. Lack of regular cleaning allows the foam concentrate to dry inside and around the percentage ball resulting in plugged metering orifices. Look down inside the metering head after flushing and check valve to ensure clean passageways.

### 10.1 SERVICE TESTING

In accordance with NFPA 1962, equipment must be tested a minimum of annually. Units failing any part of this test must be removed from service, repaired and retested upon completion of the repair.

### 10.2 REPAIR

Factory service is available with repair time seldom exceeding one day in our facility. Factory serviced equipment is repaired by experienced technicians, wet tested to original specifications, and promptly returned. All returns require a Returns Goods Authorization (RGA) number. Call TFT service department at 1-800-348-2686 to troubleshoot and if needed, obtain an RGA and directions for return.

Repair parts and service procedures are available for those wishing to perform their own repairs. Task Force Tips assumes no liability for damage to equipment or injury to personnel that is a result of user service. Contact the factory or visit the web site at [tft.com](http://tft.com) for parts lists, exploded views, test procedures and troubleshooting guides.

Performance tests shall be conducted on the equipment after a repair, or anytime a problem is reported to verify operation in accordance with TFT test procedures. Consult factory for the procedure that corresponds to the model and serial number of the equipment. Any equipment which fails the related test criteria should be removed from service immediately. Troubleshooting guides are available with each test procedure or equipment can be returned to the factory for service and testing.



**Service technicians bear responsibility for ensuring use of appropriate protective clothing and equipment. The chosen protective clothing and equipment must provide protection from potential hazards users may encounter while servicing equipment. Requirements for protective clothing and equipment are determined by the Authority Having Jurisdiction (AHJ).**



**Any alterations to the product or its markings could diminish safety and constitutes a misuse of this product.**



**All replacement parts must be obtained from the manufacturer to assure proper performance and operation of the device.**

## 11.0 TROUBLE SHOOTING

SYMPTOM	POSSIBLE CAUSE	REMEDY
Eductor picks up too much foam concentrate	Percentage Knob is set at higher percentage than desired	Turn knob to desired percentage
	Eductor inlet pressure is incorrect	Set eductor inlet pressure to pressure specified on labels
	Metering head paired with incorrect body	Use correct metering head for body
Weak Foam or No Foam	Out of foam or bucket is nearly empty	Refill tank
	Percentage knob is set to lower percentage or is set to OFF	Turn knob to desired percentage
	Percentage ball is partially or completely plugged	Take off the meter head and clean debris out of the percentage ball
	Hose lay is incorrect	Correct hose lay per training approved by the AHJ
	Eductor inlet pressure is incorrect	Set eductor inlet pressure to pressure specified on labels
	Hose is kinked	Straighten kinks out of hose
	Concentrate intake hose is completely or partially clogged	Clean debris out of concentrate intake hose
	Valve in nozzle is not fully open	Fully open valve in nozzle
	Nozzle size is incorrect	Select correct nozzle
	Nozzle is clogged	Flush nozzle to clear out debris or remove nozzle to clean debris out
	Foam has thickened due to cold temperatures	Use a foam suitable for temperatures

Table 11.0

## 12.0 EXPLODED VIEWS AND PARTS LISTS

Exploded views and parts lists are available at [tft.com/serial-number](http://tft.com/serial-number).

### 13.0 OPERATION AND INSPECTION CHECKLIST

**BEFORE EACH USE**, the Eductor must be inspected to this checklist:

1. There is no obvious damage such as missing, broken or loose parts, damaged labels, etc.
2. All controls move freely and operate properly.
3. Waterways, foam passages, and foam suction hose are not obstructed.
4. There are no leaks when the Eductor is flowing.

**BEFORE BEING PLACED BACK IN SERVICE**, the Eductor must be inspected to this list:

1. All controls and adjustments are operational.
2. There are no broken or missing parts.
3. There is no damage that could impair safe operation (e.g. detents, cracks, corrosion, or other defects).
4. The waterway is clear of obstructions.
5. The Eductor is cleaned and markings are legible.



**Equipment failing any part of the checklist is unsafe for use and must have the problem corrected before use or being placed back into service. Operating equipment that has failed the checklist is a misuse of this equipment.**