

MANUAL: EDUCTOR 125 SERIES IN-LINE

MANUAL FOR SAFE OPERATION AND MAINTENANCE

⚠️ WARNING

Read instruction manual before use. Operation of this device without understanding the manual and receiving proper training is a misuse of this equipment. Users who have not read and understood all operating and safety instructions are not qualified to operate this eductor. This instruction manual is intended to familiarize firefighters and maintenance personnel with the operation, servicing, and safety procedures associated with the eductor. This manual should be kept available to all operating and maintenance personnel.

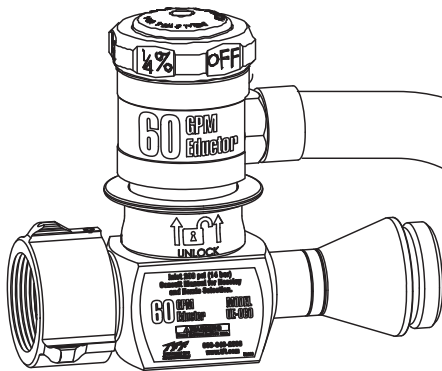

Inlet Pressure:
200 psi (13.8 bar)
160 psi (11 bar)
145 psi (10 bar)

Maximum Back Pressure:
130 psi (9 bar)
100 psi (6.9 bar)
95 psi (6.5 bar)

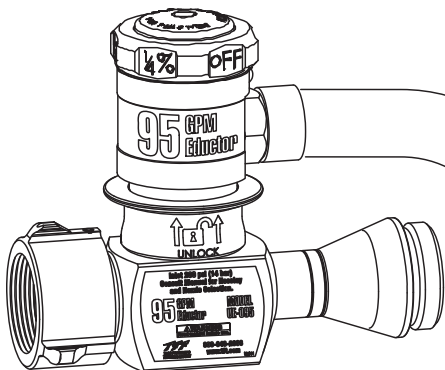

Concentration Settings
Off, 1/4%, 1/2%, 1%, 3%, 6%

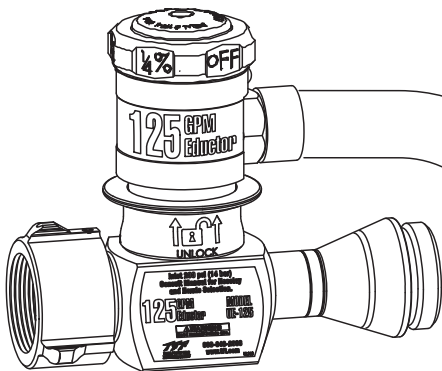

Models: 60 gpm (225 l/min)
95 gpm (360 l/min)
120 gpm (450 l/min)
125 gpm (475 l/min)



PERSONAL RESPONSIBILITY CODE

The member companies of FEMSA that provide emergency response equipment and services want responders to know and understand the following:

1. Firefighting and Emergency Response are inherently dangerous activities requiring proper training in their hazards and the use of extreme caution at all times.
2. It is your responsibility to read and understand any user's instructions, including purpose and limitations, provided with any piece of equipment you may be called upon to use.
3. It is your responsibility to know that you have been properly trained in Firefighting and /or Emergency Response and in the use, precautions, and care of any equipment you may be called upon to use.
4. It is your responsibility to be in proper physical condition and to maintain the personal skill level required to operate any equipment you may be called upon to use.
5. It is your responsibility to know that your equipment is in operable condition and has been maintained in accordance with the manufacturer's instructions.
6. Failure to follow these guidelines may result in death, burns or other severe injury.



Fire and Emergency Manufacturers and Service Association
P.O. Box 147, Lynnfield, MA 01940 • www.FEMSA.org

Table Of Contents

- 1.0 MEANING OF SIGNAL WORDS
- 2.0 SAFETY
- 3.0 GENERAL INFORMATION
 - 3.1 PART IDENTIFICATION
 - 3.2 GENERAL OPERATING INSTRUCTIONS
 - 3.3 CLEANING INSTRUCTIONS
- 4.0 FOAM SELECTION
 - 4.1 CLASS A FOAM
 - 4.2 CLASS B FOAM
 - 4.3 FOAM COMPATIBILITY
 - 4.4 FOAM CONSUMPTION
- 5.0 MAXIMUM HOSE LAY
- 6.0 NOZZLE SELECTION
- 7.0 TROUBLE-SHOOTING
- 8.0 WARRANTY
- 9.0 DRAWING AND PARTS LIST
- 10.0 FOAM BUCKET ARRANGEMENT
 - 10.1 FOAM SUPPLY LOGISTICS
- 11.0 MAINTENANCE

1.0 MEANING OF SAFETY SIGNAL WORDS

A safety related message is identified by a safety alert symbol and a signal word to indicate the level of risk involved with a particular hazard. Per ANSI standard Z535.6-2006, the definitions of the four signal words are as follows:



DANGER indicates a hazardous situation which, if not avoided, will result in death or serious injury.



WARNING indicates a hazardous situation which, if not avoided, could result in death or serious injury.



CAUTION indicates a potentially hazardous situation which, if not avoided, could result in minor or moderate injury.



NOTICE is used to address practices not related to personal injury.

2.0 SAFETY

The eductor is designed for Class A and Class B foam concentrates. If you intend to use the eductor for liquids other than Class A and Class B concentrates and water, we urge you to contact the Task Force Tips Engineering Department. The use of other liquids may void the warranty and subject the user to hazards not addressed in this manual. The user assumes all risks for non-intended uses.

- Make sure there is enough foam concentrate prepared before fighting fire. TFT's eductors are calibrated 15% more than the nominal rate, or half percent point, which ever is less. Per FOAM EQUIPMENT AND LIQUID CONCENTRATES – UL 162, the liquid concentrate induction rate of a proportioner, expressed as a percentage of the flow rate of the mixed water plus concentrate solution, shall be minus zero (0) percent, plus thirty (30) percent of the manufacturer's specified induction rate or one percent point, whichever is less.
- Make sure the meter head set to OFF position and the correct nozzle and hose lay are securely attached to the eductor before the hose line is charged.
- Make sure the nozzle gallonage matches eductor's gallonage.
- Make sure the hose lay does not exceed the maximum listed in the operating instruction.
- Make sure that the meter head is set to the correct concentration for the type of foam being used. Foam concentrates can be ineffective if not used at the correct percentage.



Lack of foam can place operator at risk of injury or death. Establish foam flow before advancing into hazardous situations. Make sure you do not run out of foam concentrate before the task is complete. Check concentrate level periodically and keep an adequate supply on hand.



Do not use Class A foam on Class B fires or Class B foam on Class A fires. Note: Some foam concentrates are universal and can be used on Class B fires and spills and as a wetting agent on Class A fires. (Refer to foam concentrate manufacturer's recommendations for proper foam choice.)



Improper use of foam can result in injury or damage to the environment. Follow the foam concentrate manufacturer's instructions and fire service training to avoid the following:

- Using the wrong type of foam on a fire, i.e. Class A foam on Class B flammable liquid fire
- Mishandling of concentrates
- Plunging foam into pools of liquid fuels
- Directing foam onto yourself or other personnel



There is a wide variety of foam concentrates. Each user is responsible for verifying that any foam concentrate chosen to be used with this unit has been tested to assure that the foam obtained is suitable for the purpose intended.

3.0 GENERAL INFORMATION

UE-060-NF	INLINE EDUCTOR 60 GPM 1.5"NH
UE-095-NF	INLINE EDUCTOR 95 GPM 1.5"NH
UE-125-NF	INLINE EDUCTOR 125 GPM 1.5"NH
UEM-225-BFBF	INLINE EDUCTOR 225 l/min at 11 bar 1.5" BSP
UEM-450-BFBF	INLINE EDUCTOR 450 l/min @ 11 bar 1.5" BSP
UEP-225-BHBH	INLINE EDUCTOR 225 l/min @ 10 bar 2.0" BSP
UEP-450-BHBH	INLINE EDUCTOR 450 l/min at 10 bar 2.0" BSP
UEP-450-BBJJ	INLINE EDUCTOR 450 l/min at 10 bar 2.5" BSP

The eductor proportioning rate ranges from 1/4%, 1/2%, 1%, 3%, to 6%.

TFT's 125 Series eductors can be used with 1/4% or 1/2% class A foam concentrates for wildland, rural and urban fire suppression on Class A fuels (wood, paper, combustible materials). On Class A materials, the eductors are intended to be used for direct extinguishment, overhaul, and wetting of fuels. Some foam concentrates are corrosive, we recommend using only Class A concentrates that have received USDA and USFS approval.

On class B materials, the eductors are primarily intended for vapor suppression or extinguishment. They can be used with high viscosity 1%, 3%, 6%, 3x3% and 3x6% Alcohol Resistant Class B concentrates on flammable liquids containing polar solvents.

The eductor can also be used with plain AFFF concentrates rated at 1%, 3%, or 6%, with various freeze protected foams, and with FFFP foam types. These foams generally have a lower viscosity than the calibration viscosity of the TFT eductor and will be inducted faster than expected resulting in stronger concentrations. While this does not degrade foam quality, it does reduce the operating time for a given foam supply.

Standard inlet operating pressure is 200 psi (13.8 bar) on 125 Series eductors. Custom designs are also available with inlet operating pressures of 160 psi (11 bar) and 145 psi (10 bar).

3.1 PART IDENTIFICATION

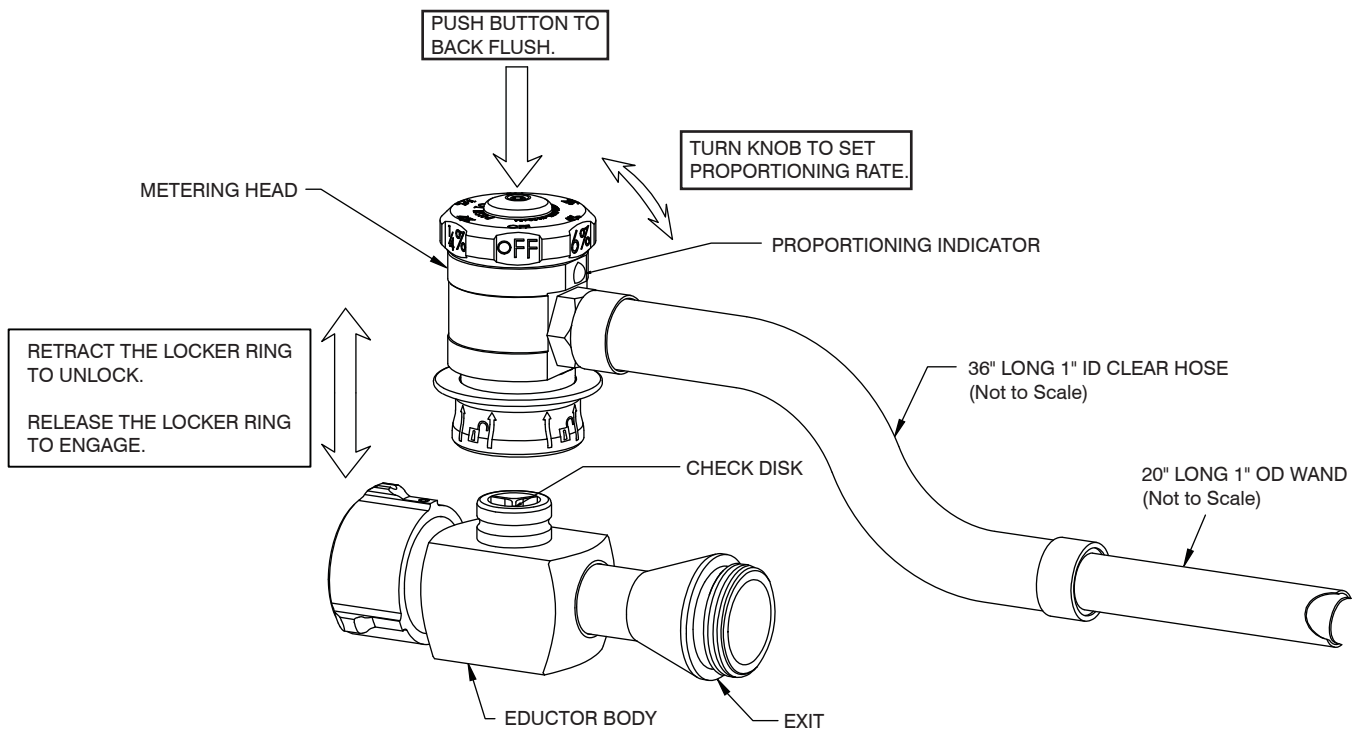

Fig 3.1

3.1 PART IDENTIFICATION cont.

The eductor can be split into two parts by grasping the locking ring and retracting it fully to separate the metering head from the eductor body. All the foam passageways can easily be inspected. The foam passageway into the eductor contains a free-floating check disk with three fins. The check disk is pressure activated to keep water from coming out of the fire hose and back into the foam pail.

The metering head contains a red back flush button that can be depressed to open the check disk.

The metering head also has a large proportioning knob that can be rotated to align a ball valve to six different detent positions: Off, 1/4%, 1/2%, 1%, 3% & 6%. Each foam setting has a precision sized metering orifice in the valve ball. The eductor cannot be operated between settings, as the metering orifices will not line up properly. The setting on the proportioning knob lines up with the white indicator ball.

The eductor body is equipped with two 5/16-18, 3/4" deep mounting holes with set screw plugs. To mount the unit, remove the set screws and attach to the desired location using bolts with enough length to provide at least 1/2" engagement with the unit.

3.2 GENERAL OPERATING INSTRUCTION

- 1) Choose the right foam concentrate (see section 4)
- 2) Lay the right hose (see section 5)
- 3) Connect the right nozzle (see section 6)
- 4) Charge the hose and open the nozzle fully to establish the water flow.
- 5) Adjust the pump pressure so the eductor inlet is set at its rated pressure of 200 PSI (13.8 bar), 160 PSI (11 bar) or 145 PSI (10 bar).
- 6) Put the wand in the bucket and rotate the percentage knob to the desired concentration.

3.3 CLEANING INSTRUCTIONS

After use take the wand out of the bucket and turn down the pump pressure below 75 PSI (5 bar). Shut off the nozzle. Restrain the wand and expect a rapid discharge of water especially at 6% setting. Push the red flush button and run fresh water through the wand and metering head on each setting until there is no visible foam in the flush water.

Retract the lock ring to remove the metering head. Turn off the water supply and remove the eductor from the hose so that any remaining foam residue can be washed from the wand, metering head, and eductor.

CAUTION

Do not back flush above 75 psi (5 bar). Rapid back flush discharge from the wand could cause injury. The back flush push button is pressure activated and must not be forced at pressures over 75 psi (5 bar).

4.0 FOAM SELECTION

Actual foam concentrations vary with changes in water flow, foam concentrate temperature and viscosity. The user must verify that the concentrate's performance is suitable for use in their application. In all cases, the manufacturer's recommendations must be followed.

CAUTION

Class A foam concentrates are generally less viscous than Class B foam concentrates. Using 1% Class B foam percentage setting to educt Class A foam, may cause the actual Class A foam percentage to be more than 1%.

4.1 CLASS A FOAM

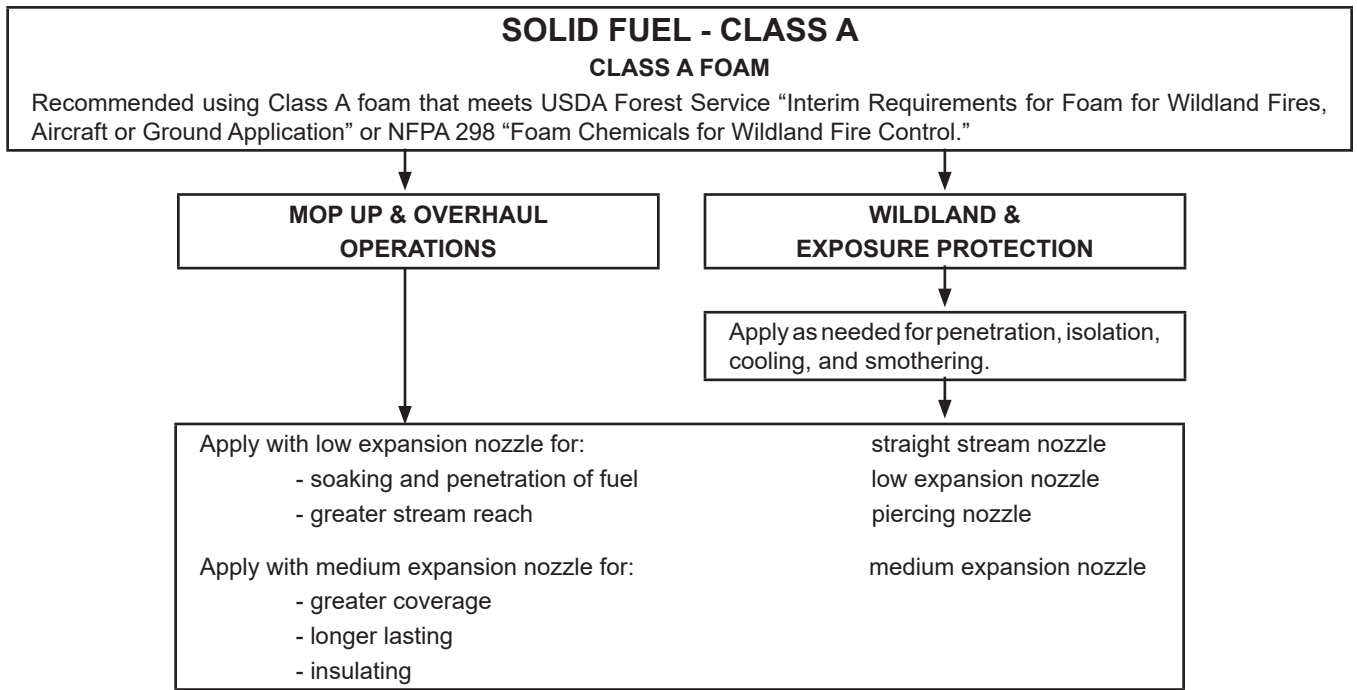

4.2 CLASS B FOAM

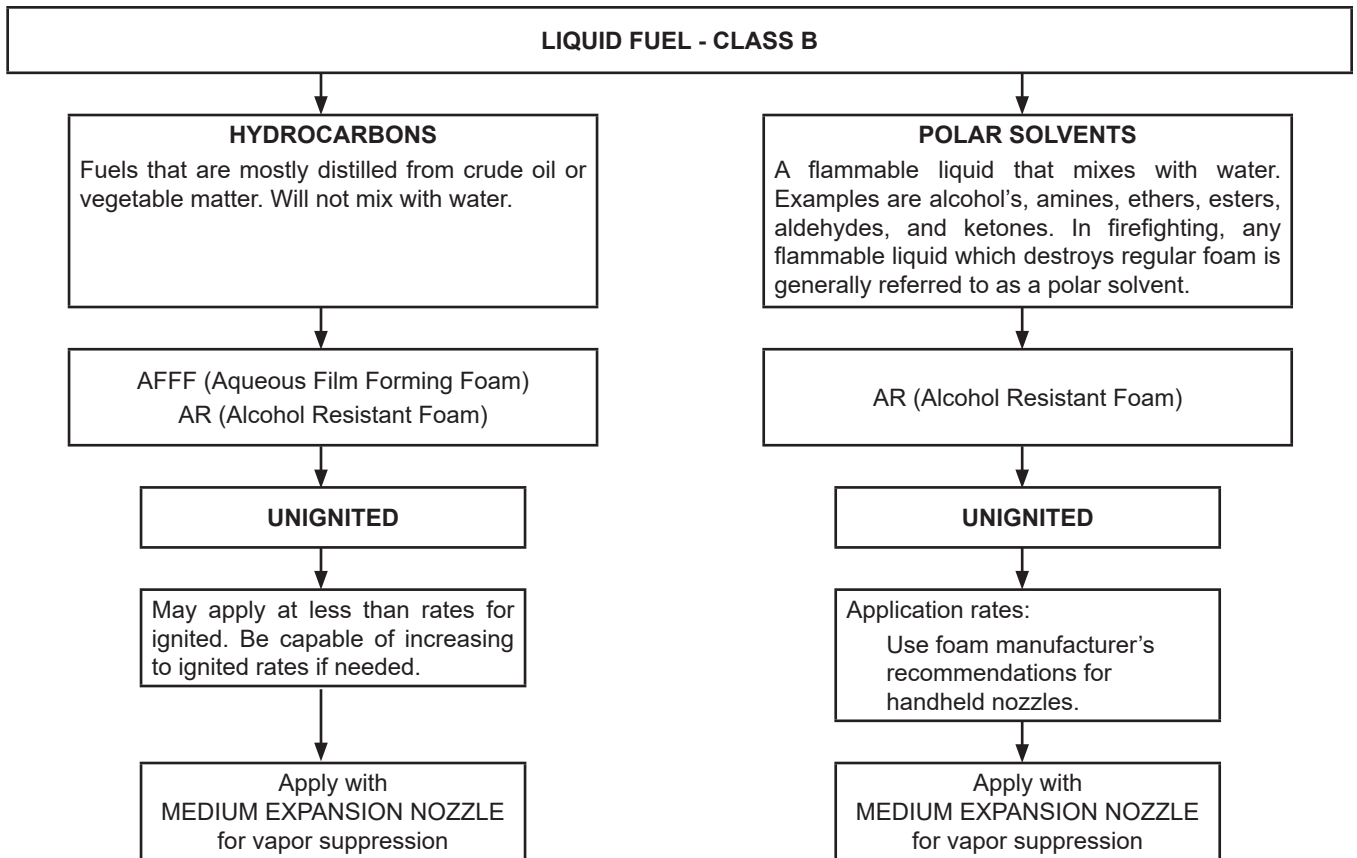

4.3 FOAM COMPATIBILITY



Do not mix different types of foam concentrates or foams of the same type from different manufacturers. Mixing of foam concentrates can cause the contents of the foam tank to gel and produce unpredictable results. Clean tank and foam passages thoroughly when changing foam types.

Medium Expansion Nozzle — produces the greatest expansion ratios. It should be used on Class B fuels for vapor suppression and Class A fuels when a longer lasting insulating layer of drier foam is desired.

Low Expansion Nozzle — can be used with either Class A or B foam solutions. Reach is slightly less than the smooth bore. It should be used on Class B fires for extinguishment and Class A fuels to soak the fuel with a wet foam solution.

Straight Stream Nozzle — is for Class A foam solutions. Foam expansion will be negligible. It should be used where maximum reach or penetration is desired.

4.4 FOAM CONSUMPTION

The following tables indicate the theoretical foam concentrate flow rate and the time it will take to empty a 5 gallon (18.9 liters) container of various concentrates with eductors of different ratings.

60 GPM (225 l/min) Eductor

Setting	Foam Class	Time To Empty 5 G (18.9 L)	Foam Flow Rate
1/4%	A	33 min 20 sec	0.15 gpm 0.57 l/min
1/2%	A	16 min 40 sec	0.3 gpm 1.14 l/min
1%	B	8 min 20 sec	0.6 gpm 2.27 l/min
3%	B	2 min 47 sec	1.8 gpm 6.81 l/min
6%	B	1 min 23 sec	3.6 gpm 13.62 l/min

95 GPM (360 l/min) Eductor

Setting	Foam Class	Time To Empty 5 G (18.9 L)	Foam Flow Rate
1/4%	A	20 min 50 sec	0.24 gpm 0.9 l/min
1/2%	A	10 min 25 sec	0.5 gpm 1.89 l/min
1%	B	5 min 16 sec	1.0 gpm 3.78 l/min
3%	B	1 min 45 sec	2.9 gpm 10.97 l/min
6%	B	53 sec	5.7 gpm 21.57 l/min

120 GPM (450 l/min) Eductor

Setting	Foam Class	Time To Empty 5 G (18.9 L)	Foam Flow Rate
1/4%	A	16 min 40 sec	0.29 gpm 1.09 l/min
1/2%	A	8 min 20 sec	0.58 gpm 2.18 l/min
1%	B	4 min 10 sec	1.25 gpm 4.72 l/min
3%	B	1 min 23 sec	3.65 gpm 13.8 l/min
6%	B	42 sec	7.2 gpm 27.25 l/min

125 GPM (475 l/min) Eductor

Setting	Foam Class	Time To Empty 5 Gallons	Foam Flow Rate
1/4%	A	16 min	0.3 gpm 1.14 l/min
1/2%	A	8 min	0.6 gpm 2.27 l/min
1%	B	4 min	1.3 gpm 4.92 l/min
3%	B	1 min 20 sec	3.8 gpm 14.38 l/min
6%	B	40 sec	7.5 gpm 28.38 l/min

- The class A foam used for calibration is the “Knock Down” from National Foam. The calibration viscosity is 20 Centipoise.
- The class B foam used for calibration is the “Universal Plus 3% /6% Alcohol Resistant Aqueous Film Forming Foam” (AR-AFFF) from National Foam. The calibration viscosity is 2892 centipoise tested with Brookfield #3 Spindle @ 30 rpm.
- TFT’s eductors were calibrated with 1 3/4” Conquest Hose.
 UE-060-NF calibration hose length is 300 ft.
 UE-095-NF calibration hose length is 250 ft.
 UE-125-NF calibration hose length is 150 ft.

Actual calibrated rate for each setting and the foam concentrate used for calibration

SETTING	ACTUAL RATE	FOAM CLASS	UL-162 TOLERANCE
1/4%	0.287%	A	.25 - .325%
1/2%	0.575%	A	.5 - .65%%
1%	1.15%	B	1 - 1.3%
3%	3.45%	B	3 - 3.9%
6%	6.5%	B	6 - 7.8%

5.0 MAXIMUM HOSE LAY

The maximum hose lay is based on the back pressure. Pushing the foam solution thru the hose and nozzle causes back pressure on the eductor exit.

- On a 200 psi (13.8 bar) model, if the back pressure is over 130 psi (9 bar) the eductor will not work.
- On a 160 psi (11 bar) model, if the back pressure is over 100 psi (6.9 bar) the eductor will not work.
- On a 145 psi (10 bar) model, if the back pressure is over 95 psi (6.5 bar) the eductor will not work.

Elevation loss adds to the back pressure when the nozzle is higher than the eductor, e.g. 0.4 psi / foot and 0.1 bar / meter in vertical height elevation loss.

⚠ WARNING Do not exceed the allowable back pressure. Excess back pressure causes loss of foam flow resulting in risk of injury or death from an ineffective stream. Verify that adequate foam flow is established and maintained.

The following table shows the reference friction loss based on typical USA water flow/hose length/size. To calculate the back pressure, add the nozzle pressure, hose friction loss, and elevation pressure loss together, and make sure the sum does not exceed 130 psi (9 bar).

Eductor Rating	Hose Size Inch	3% - 6% Solution				Up to 1% Solution			
		100 psi Nozzle		75 psi Nozzle		100 psi Nozzle		75 psi Nozzle	
		Maximum Hose Lay Ft	Elevation Ft	Maximum Hose Lay Ft	Elevation Ft	Maximum Hose Lay Ft	Elevation Ft	Maximum Hose Lay Ft	Elevation Ft
60 GPM at 200 PSI	1.5	300	10	600	10	450	10	800	10
		100	50	400	50	250	50	600	50
		—	—	150	100	—	—	300	100
	1.75	450	10	900	10	700	10	1200	10
		150	50	600	50	400	50	900	50
		—	—	250	100	—	—	500	100
	2	950	10	1800	10	1300	10	2000	20
		300	50	1200	50	750	50	1200	75
		—	—	500	100	50	100	750	100
95 GPM at 200 PSI	1.5	100	10	200	10	150	10	300	10
		—	—	150	50	100	50	200	50
		—	—	—	—	—	—	100	100
	1.75	200	10	350	10	300	10	450	10
		—	—	250	50	150	50	350	50
		—	—	100	100	—	—	200	100
	2	350	10	700	10	500	10	900	10
		150	50	500	50	300	50	600	50
		—	—	150	100	—	—	300	100
125 GPM at 200 PSI	1.5	60	10	120	10	100	10	150	10
		—	—	80	50	50	50	100	50
		—	—	—	—	—	—	50	100
	1.75	100	10	200	10	150	10	250	10
		—	—	150	50	100	50	200	50
		—	—	—	—	—	—	100	100
	2	200	10	400	10	350	10	550	10
		100	50	250	50	200	50	400	50
		—	—	100	100	—	—	250	100

Similar charts can be created for eductors of other ratings and/or hoses of different standard lengths and/or sizes. Friction loss will also vary with the hose design and manufacturer, so it is important to know the characteristics of your hose.

The nominal flow of the eductor is the sum of water plus foam concentrate when set at 6%. The eductor should always have its rated pressure at the inlet. The water flow does not change with different percentage settings; however, the inducted foam concentrate will change when the percentage setting is changed. Therefore, the total flow exiting the eductor is lower at 1/4% than at 6%. Longer hose lengths can be used when proportioning rate is less because less work is needed to move lower total flows.

6.0 NOZZLE SELECTION

Eductors work with any nozzle whose gallonage is equal to or larger than eductors'. However, if a larger gallonage nozzle is used, the reach of nozzle and the proportioning rate of the eductor will be compromised.

Fog-type nozzles have the greatest reach in the straight stream position. The finished foam is produced as the stream projects forward, and the greatest expansion is at the end of the stream. While straight stream gives maximum reach, it can also splash flammable liquids if not carefully applied. The stream impact can be softened by deflecting the stream off nearby objects. The stream can also be trimmed to a 10-15 degree pattern which gives good reach and creates a softer "snow-flaking" effect at the end of the stream.

The expansion ratio is the amount of finished foam produced compared to the volume of foam concentrate/water solution used to generate the foam. For Example: A 10:1 expansion ratio will produce 950 GPM (3600 l/min) of finished foam from a 95 GPM (360 l/min) nozzle. Non-aspirated automatic nozzles can produce expansion ratios of 6-8:1 when measured at the end of the stream. By maintaining a constant nozzle pressure, automatic nozzles keep the velocity of the stream high. Large amounts of air are pulled into the stream and mix with the foam concentrate/water solution as the stream leaves the nozzle.

Air-aspirating devices, such as the TFT FOAMJET, allow a wider selection of foam concentrates to be used, and can produce a better quality of finished foam. Air-aspirating attachments will, (1) improve the 1/4 drain time, (2) produce a more uniform bubble structure, (3) improve the burn back resistance of the finished foam, and (4) the foam blanket is visibly thicker. This thicker foam blanket has better vapor suppression and is longer lasting than foam from non-aspirated nozzles. The final expansion ratio and, therefore, the amount of finished foam, depends on the type of foam concentrate being used.



The nozzle must be operated fully open to prevent excessive back pressure which will prevent foam pickup. Lack of foam can result in injury or death.

The following tables list the compatibility between eductors and nozzles. NOTE: A 75 psi (5 bar) nozzle will result in lower nozzle pressure and shorter stream reach.

UE-060 EDUCTOR
60 GPM (225 l/min)
200 PSI (13.8 bar) Inlet Pressure

Nozzle Name	Nozzle Model #	Water Flow Setting	Nozzle Pressure	Low Expansion Foam Attachment	Multi-Expansion Foam Attachment
Twister	F2060, FS2060, FS2060P	60 gpm 230 l/min	100 psi 7 bar	NONE	FJ-MX-F
Bubble Cup	F2060BC, FS2060BC, FS2060BCP	60 gpm 230 l/min	100 psi 7 bar	BUILT IN	BUILT-IN
Metro 0	ME0**	60 gpm 230 l/min	100 or 75 psi 7 or 5 bar	FJ-U FJ-LX-U	FJ-UMX
1.0" Quadrafog	DQ60, DQS60, DQS60P	5-10-24-40-60 gpm 20-40-90-150-230 l/min	100 psi 7 bar	FJ-DQ	FJ-MX-DQ
1.0" G-Force	Selectable Flow Fixed Pressure	15-30-45-60-75 gpm 55-110-170-230-285 l/min	100 or 75 psi 7 or 5 bar	FJ-GD FJ-LX-U	FJ-UMX
1.0" G-Force	Automatic Pressure with Variable Flow	30 - 80 gpm 110 - 300 l/min	100 or 75 psi 7 or 5 bar	FJ-GD FJ-LX-U	FJ-UMX
Ultimatic	B-*, BTO-*, BH-*, BGH-*	10-125 gpm 40 - 475 l/min	100 psi 7 bar	FJ-U FJ-LX-U	FJ-UMX
	BL-*, BTOL-*, BHL-*, BGHL-*	10-100 gpm 40 - 400 l/min	75 psi 5 bar		
Metro 1	ME1**	60 gpm 230 l/min	100 or 75 psi 7 or 5 bar	FJ-HM FJ-LX-HM	FJ-MX-HM
1.5" Quadrafog	FQ125**, FQS125**	30-60-95-125 gpm 110-230-360-470 l/min	100 or 75 psi 7 or 5 bar	FJ-LX-FQ	FJ-MX-FQ
QuadraCup	FQ125BC, FQS125BC**, FQCS**	30-60-95-125 gpm 110-230-360-470 l/min	100 or 75 psi 7 or 5 bar	BUILT-IN	BUILT-IN
G-Force	Selectable Flow Fixed Pressure	30-60-95-125-150 gpm 110-230-360-470-570 l/min	100 or 75 psi 7 or 5 bar	FJ-LX-G	FJ-MX-G
G-Force	Automatic Pressure with Variable Flow	60 - 150 gpm 230 - 570 l/min	100 or 75 psi 7 or 5 bar	FJ-LX-G	FJ-MX-G
Thunderfog	FT200*, FTS200*	30-60-95-125-150-200 gpm 110-230-360-470-570-750 l/min	100 or 75 psi 7 or 5 bar	NONE	FJ-MX-FT

UE-095 EDUCTOR
95 GPM (360 l/min)
200 PSI (13.8 bar) Inlet Pressure

Nozzle Name	Nozzle Model #	Water Flow Setting GPM	Nozzle Pressure psi	Low Expansion Foam Attachment	Multi-Expansion Foam Attachment
Twister	F2095, FS2095, FS2095P	95 gpm 360 l/min	100 psi 7 bar	NONE	FJ-MX-F
Bubble Cup	F2095BC, F95BC, FS2095BC, FS95BC, FS2095BCP, FS95BCP	95 gpm 360 l/min	100 psi 7 bar	BUILT IN	BUILT-IN
Ultimatic	B-*, BTO-*, BH-*, BGH-*	10-125 gpm 40 - 475 l/min	100 psi 7 bar	FJ-U FJ-LX-U	FJ-UMX
	BL-*, BTOL-*, BHL-*, BGHL-*	10-100 gpm 40 - 400 l/min	75 psi 5 bar		
Metro 1	ME1*	95 gpm 360 l/min	100 or 50 psi 7 or 3 bar	FJ-HM FJ-LX-HM	FJ-MX-HM
Quadrafog	FQ**, FQS**	30-60-95-125 gpm 110-230-360-470 l/min	100 or 75 psi 7 or 5 bar	FJ-LX-FQ	FJ-MX-FQ
QuadraCup	FQ125BC, FQ125BC**, FQCS**	30-60-95-125 gpm 110-230-360-470 l/min	100 or 75 psi 7 or 5 bar	BUILT-IN	BUILT-IN
1.5" G-Force	Selectable Flow Fixed Pressure	30-60-95-125-150 gpm 110-230-360-470-570 l/min	100 or 75 psi 7 or 5 bar	FJ-LX-G	FJ-MX-G
1.5" G-Force	Automatic Pressure with Variable Flow	60 - 150 gpm 230 - 570 l/min	100 or 75 psi 7 or 5 bar	FJ-LX-G	FJ-MX-G
Thunderfog	FT200*, FTS200*, FT250*, FTS250*, JT250*, JTS250*	30-60-95-125-150-200 gpm 110-230-360-470-570-750 l/min	100 or 75 psi 7 or 5 bar	NONE	FJ-MX-FT
Thunderfog	FT250**, FTS250*, FTS**, JT**, JTS**	95-125-150-200-250 gpm 360-470-570-680-950 l/min	100 psi 7 bar	NONE	FJ-MX-FT
Metro 2	ME2**	95 gpm 360 l/min	100 psi 7 bar	FJ-H	FJ-MX-FT
Mid-Matic	HM-**, HML-**	70 - 200 gpm 260 - 760 l/min	100 or 75 psi 7 or 5 bar	FJ-HM FJ-LX-HM	FJ-MX-HM
	HMK-*	70 - 180 gpm 260 - 680 l/min	55 psi 4 bar		
Mid-Force	HMD-**, HMDL-**	70 - 200 gpm 270 - 760 l/min	100 or 75 psi 7 or 5 bar	FJ-HM FJ-LX-HM	FJ-MX-HM
Handline	H-**	95 - 300 gpm 360 - 1140 l/min	100 psi 7 bar	FJ-H	FJ-HMX
	HL-**	95 - 250 gpm 360 - 950 l/min	75 psi 5 bar		
	HK-**	95 - 225 gpm 360 - 850 l/min	55 psi 4 bar		
Dual-Force	HD-**	95 - 300 gpm 360 - 1150 l/min	100 psi 7 bar	FJ-H	FJ-HMX
	HDL-**	95 - 250 gpm 360 - 950 l/min	75 psi 5 bar		

UE-125 EDUCTOR
125 GPM (475 l/min)
200 PSI (13.8 bar) Inlet Pressure

Nozzle Name	Nozzle Model #	Water Flow Setting	Nozzle Pressure	Low Expansion Foam Attachment	Multi-Expansion Foam Attachment
Ultimatic	B-**	10-125 gpm 40-475 l/min	100 psi 7 bar	FJ-U FJ-LX-U	FJ-UMX
Metro 1	ME1*	125 gpm 475 l/min	100, 75 or 50 psi 7, 5 or 4 bar	FJ-HM FJ-LX-HM	FJ-MX-HM
Quadrafog	FQ125**, FQS125**	30-60-95-125 gpm 110-230-360-470 l/min	100 or 75 psi 7 or 5 bar	FJ-LX-FQ	FJ-MX-FQ
QuadraCup	FQ125BC, FQ125BC**, FQCS**	30-60-95-125 gpm 110-230-360-470 l/min	100 or 75 psi 7 or 5 bar	BUILT-IN	BUILT-IN
1.5" G-Force	Selectable Flow Fixed Pressure	30-60-95-125-150 gpm 110-230-360-470-570 l/min	100 or 75 psi 7 or 5 bar	FJ-LX-G	FJ-MX-G
1.5" G-Force	Automatic Pressure with Variable Flow	60 - 150 gpm 230 - 570 l/min	100 or 75 psi 7 or 5 bar	FJ-LX-G	FJ-MX-G
Thunderfog	FT200*, FTS200*, FTS*,	30-60-95-125-150-200 gpm 110-230-360-470-570-750 l/min	100 or 75 psi 7 or 5 bar	NONE	FJ-MX-FT
Thunderfog	FT250*, FTS250*, FTS**, JT**, JTS**	95-125-150-200-250 gpm 360-470-570-760-950 l/min	100 or 75 psi 7 or 5 bar	NONE	FJ-MX-FT
Metro 2	ME2*	125 gpm 475 l/min	75 psi 5 bar	FJ-H	FJ-HMX
Mid-Matic	HM-**, HML-*	70 - 200 gpm 260 - 760 l/min	100 or 75 psi 7 or 5 bar	FJ-LX-HM	FJ-MX-HM
	HMK-*	70 - 180 gpm 260 - 680 l/min	55 psi 4 bar		
Mid-Force	HMD-**	70 - 200 gpm 260 - 760 l/min	100 or 75 psi 7 or 5 bar	FJ-HM FJ-LX-HM	FJ-MX-HM
Handline	H-**	95 - 300 gpm 360 - 1160 l/min	100 psi 7 bar	FJ-H	FJ-HMX
	HL-**	95 - 250 gpm 360- 950 l/min	75 psi 5 bar		
	HK-**	95-225 gpm 360-850 l/min	55 psi 4 bar		
Dual-Force	HD-**	95 - 300 gpm 360 - 1150 l/min	100 psi 7 bar	FJ-H	FJ-HMX
	HDL-**	95 - 250 gpm 360- 950 l/min	75 psi 5 bar		

UEM-225 EDUCTOR
60 GPM (225 l/min)
160 PSI (11 bar) Inlet Pressure

Nozzle Name	Nozzle Model #	Water Flow Setting	Nozzle Pressure	Low Expansion Foam Attachment	Multi-Expansion Foam Attachment
Metro 0	ME0**	60 gpm 220 l/min	75 psi 5 bar	FJ-U FJ-LX-U	FJ-UMX
1.0" G-Force	Selectable Flow Fixed Pressure	15-30-45-60-75 gpm 55-110-170-230-285 l/min	75 psi 5 bar	FJ-GD FJ-LX-U	FJ-UMX
1.0" G-Force	Automatic Pressure with Variable Flow	30 - 80 gpm 110 - 300 l/min	75 psi 5 bar	FJ-GD FJ-LX-U	FJ-UMX
Ultimatic	BL, BTOL, BHL, BGHL	10-100 gpm 40-400 l/min	75 psi 5 bar	FJ-U FJ-LX-U	FJ-UMX
Metro 1	ME1*	60 gpm 230 l/min	75 psi 5 bar	FJ-HM FJ-LX-HM	FJ-MX-HM
1.5" Quadrafog	FQ**, FQS**	30-60-95-125 gpm 110-230-360-470 l/min	75 psi 5 bar	FJ-LX-FQ	FJ-MX-FQ
QuadraCup	FQ125BC, FQ125BC**, FQCS**	30-60-95-125 gpm 110-230-360-470 l/min	75 psi 5 bar	BUILT-IN	BUILT-IN
1.5" G-Force	Selectable Flow Fixed Pressure	30-60-95-125-150 gpm 110-230-360-470-570 l/min	75 psi 5 bar	FJ-LX-G	FJ-MX-G
1.5" G-Force	Automatic Pressure with Variable Flow	60 - 150 gpm 230 - 570 l/min	75 psi 5 bar	FJ-LX-G	FJ-MX-G
Thunderfog	FT200*, FTS200*, FTS*,	30-60-95-125-150-200 gpm 110-230-360-470-570-750 l/min	75 psi 5 bar	NONE	FJ-MX-FT

UEM-450 EDUCTOR
120 GPM (450 l/min)
160 PSI (11 bar) Inlet Pressure

Nozzle Name	Nozzle Model #	Water Flow Setting	Nozzle Pressure	Low Expansion Foam Attachment	Multi-Expansion Foam Attachment
Metro 1	ME1*	125 gpm 475 l/min	75 or 50 psi 5 or 3 bar	FJ-HM FJ-LX-HM	FJ-MX-HM
1.5" Quadrafog	FQ**, FQS**	30-60-95-125 gpm 110-230-360-470 l/min	75 psi 5 bar	FJ-LX-FQ	FJ-MX-FQ
QuadraCup	FQ125BC, FQ125BC**, FQCS**	30-60-95-125 gpm 110-230-360-470 l/min	75 psi 5 bar	BUILT-IN	BUILT-IN
1.5" G-Force	Selectable Flow Fixed Pressure	30-60-95-125-150 gpm 110-230-360-470-570 l/min	75 psi 5 bar	FJ-LX-G	FJ-MX-G
1.5" G-Force	Automatic Pressure with Variable Flow	60 - 150 gpm 230 - 570 l/min	75 psi 5 bar	FJ-LX-G	FJ-MX-G
Thunderfog	FT200*, FTS200*, FTS*	30-60-95-125-150-200 gpm 110-230-360-470-570-750 l/min	75 psi 5 bar	NONE	FJ-MX-FT
Metro 2	ME2*	125 gpm 475 l/min	75 psi 5 bar	FJ-H	FJ-HMX
Mid-Matic	HML-*	70 - 200 gpm 260 - 760 l/min	75 psi 5 bar	FJ-LX-HM	FJ-MX-HM
	HMK-*	70 - 180 gpm 260 - 680 l/min	55 psi 4 bar		
Mid-Force	HMDL-**	70 - 200 gpm 260 - 760 l/min	75 psi 5 bar	FJ-HM FJ-LX-HM	FJ-MX-HM
Handline	HL-**	95 - 250 gpm 360 - 950 l/min	75 psi 5 bar	FJ-H	FJ-HMX
	HK-**	95-225 gpm 360-850 l/min	55 psi 4 bar		
Dual-Force	HDL-**	95 - 250 gpm 360 - 950 l/min	75 psi 5 bar	FJ-H	FJ-HMX

7.0 TROUBLE-SHOOTING

SYMPTOM	POSSIBLE CAUSE	REMEDY
Eductor picks up too much foam	Percentage Knob is set at higher percentage	Select desired percentage
	Eductor inlet pressure is lower than 200 psi (13.8 bar)	Set the eductor inlet pressure to 200 psi (13.8 bar)
	Wrong metering head	Use correct metering head
Weak Foam or No Foam	Out of foam or nearly empty	Refill Tank
	Percentage knob is OFF or in wrong percentage	Select desired percentage
	Percentage ball is plugged or partially plugged	Take off the meter head, clean out debris in the percentage ball
	Hose being used which is too long or too small in diameter	Change the hose to correct length and diameter per 5.0
	Pump pressure is too low or too high	Set eductor inlet pressure at 200 psi (13.8 bar)
	Hose kinks	Straighten the kinked hose
	Pick up tube plugged or partially plugged	Clean out the plugged pick up tube
	Nozzle is not fully open	Fully open the valve on the nozzle
	Nozzle size is smaller than eductor's rating	Select a nozzle with equal or larger gallonage than eductor's
	Debris in nozzle	Flush nozzle to clean out debris. If it didn't work, retreat, take off the nozzle and clean out the gasket grabber.
	Foam gets thick when cold	Select Another Foam

8.0 WARRANTY

Task Force Tips, Inc., 3701 Innovation Way, Valparaiso, Indiana 46383-9327 USA ("TFT") warrants to the original purchaser of its nozzles and other equipment ("equipment"), and to anyone to whom it is transferred, that the equipment shall be free from defects in material and workmanship during the five (5) year period from the date of purchase.

TFT's obligation under this warranty is specifically limited to replacing or repairing the equipment (or its parts) which are shown by TFT's examination to be in a defective condition attributable to TFT. To qualify for this limited warranty, the claimant must return the equipment to TFT, at 3701 Innovation Way, Valparaiso, Indiana 46383-9327 USA, within a reasonable time after discovery of the defect. TFT will examine the equipment. If TFT determines that there is a defect attributable to it, it will correct the problem within a reasonable time. If the equipment is covered by this limited warranty, TFT will assume the expenses of repair.

If any defect attributable to TFT under this limited warranty cannot be reasonably cured by repair or replacement, TFT may elect to refund the purchase price of the equipment, less reasonable depreciation, in complete discharge of its obligations under this limited warranty. If TFT makes this election, claimant shall return the equipment to TFT free and clear of any liens and encumbrances.

This is a limited warranty. The original purchaser of the equipment, any person to whom it is transferred, and any person who is an intended or unintended beneficiary of the equipment, shall not be entitled to recover from TFT any consequential or incidental damages for injury to person and/or property resulting from any defective equipment manufactured or assembled by TFT. It is agreed and understood that the price stated for the equipment is in part consideration for limiting TFT's liability. Some states or countries do not allow the exclusion or limitation of incidental or consequential damages, so the above may not apply to you.

TFT shall have no obligation under this limited warranty if the equipment is, or has been, misused or neglected (including failure to provide reasonable maintenance) or if there have been accidents to the equipment or if it has been repaired or altered by someone else.

THIS IS A LIMITED EXPRESS WARRANTY ONLY. TFT EXPRESSLY DISCLAIMS WITH RESPECT TO THE EQUIPMENT ALL IMPLIED WARRANTIES OF MERCHANTABILITY AND ALL IMPLIED WARRANTIES OF FITNESS FOR A PARTICULAR PURPOSE. THERE IS NO WARRANTY OF ANY NATURE MADE BY TFT BEYOND THAT STATED IN THE DOCUMENT.

This limited warranty gives you specific legal rights, and you may also have other rights which vary from state to state.

9.0 DRAWINGS & PARTS LIST

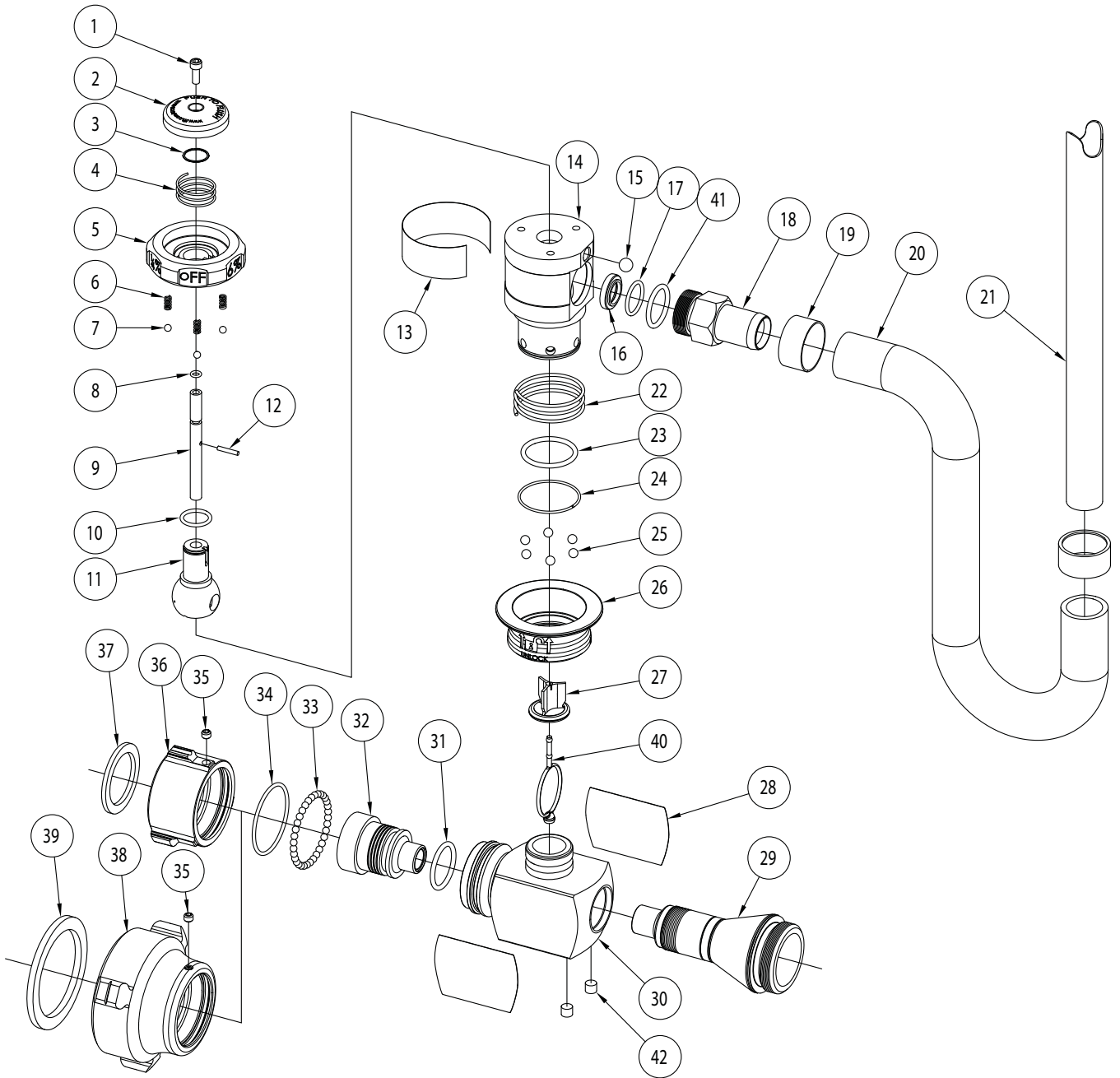

9.0 DRAWINGS & PARTS LIST

ITEM	DESCRIPTION	QTY	PART
1	10-24 X 1/2 SOCKET HEAD CAP SCREW	1	VT10-24SH500
2	PALM BUTTON - RED ANODIZE	1	UE250
3	RETAINING RING 11/16" EXTERNAL	1	VR4285
4	BUTTON SPRING	1	UE205
5	PROPORTIONING KNOB	1	UE240
6	SPRING HELICAL COMPRESSION	3	VM4195
7	3/16" BALL - TORLON	3	V2120-TORLON
8	O-RING-008 3/16 ID 1/16 C/S	1	VO-008
9	BACK FLUSH PIN	1	UE220
10	O-RING-115 11/16 ID 3/32 C/S	1	VO-115
11	BALL 60 GPM - NO GROOVES	1	UE230
	BALL 95 GPM - 1 GROOVE	1	UE231
	BALL 125 GPM - 2 GROOVES	1	UE232
	BALL 225 LPM	1	UE233
	BALL 450 LPM	1	UE234
12	7/64 X 5/8 HDP SPIROL PIN	1	VP109X625H
13	METER LABEL 60 GPM	1	UL200
	METER LABEL 95 GPM	1	UL201
	METER LABEL 125 GPM	1	UL202
	METER LABEL 225 LPM @11 BAR	1	UL207
	METER LABEL 450 LPM @ 11 BAR	1	UL208
	METER LABEL 225 LPM @ 10 BAR	1	UL203F
	METER LABEL 450 LPM @ 10 BAR	1	UL204F
14	METER HEAD	1	UE235
15	BALL 3/8" - POLYETHYLENE	1	VB375PE
16	SEAT: PROPORTIONING BALL	1	UE335
17	O-RING-117 13/16 ID 3/32 C/S	1	VO-117
18	BARB FITTING	1	UE310
19	HOSE CLAMP	2	UE340
20	SUCTION HOSE 1"ID 1.25"OD CLEAR	1	UE320
21	SUCTION WAND	1	UE330
22	SPRING - LOCKER RING	1	UE215
23	O-RING-219	1	VO-219
24	LOCATION RING	1	UE245
25	1/4" BALL - 302 STAINLESS STEEL	6	V2125
26	LOCKER	1	UE210
27	CHECK DISK	1	UE225

ITEM	DESCRIPTION	QTY	PART
28	NAME LABEL - 60GPM EDUCTOR	2	UL210
	NAME LABEL - 95GPM EDUCTOR	2	UL211
	NAME LABEL - 125GPM EDUCTOR	2	UL212
	NAME LABEL - 225 LPM @ 11 BAR	2	UL217
	NAME LABEL - 450 LPM @ 11 BAR	2	UL218
	NAME LABEL - 225 LPM @ 10 BAR	2	UL213F
	NAME LABEL - 450 LPM @ 10 BAR	2	UL214F
29	EXIT 60 GPM 1.5"NPSH - NO GROOVES	1	UE100IF
	EXIT 60 GPM 1.5"NH - NO GROOVES	1	UE100NF
	EXIT 95 GPM 1.5"NPSH - 1 GROOVE	1	UE101IF
	EXIT 95 GPM 1.5"NH - 1 GROOVE	1	UE101NF
	EXIT 125 GPM 1.5"NPSH - 2 GROOVES	1	UE102IF
	EXIT 125 GPM 1.5"NH - 2 GROOVES	1	UE102NF
	EXIT 225 LPM @ 11 BAR 1.5" BSP	1	UE133BF
	EXIT 450 LPM @ 11 BAR 1.5" BSP	1	UE124BF
	EXIT 225 LPM @ 10 BAR 2.0" BSP	1	UE133BH
	EXIT 450 LPM @ 10 BAR 2.0" BSP	1	UE134BH
	EXIT 450 LPM @ 10 BAR 2.5" BSP	1	UE144BJ
30	INTERSECTION	1	UE120
31	O-RING-216 1-1/8 ID 1/8 C/S	1	VO-216
32	BLENDING TUBE 60GPM - NO GROOVES	1	UE110
	BLENDING TUBE 95GPM - 1 GROOVE	1	UE111
	BLENDING TUBE 125GPM - 2 GROOVES	1	UE112
	BLENDING TUBE 225 LPM @ 11 BAR	1	UE116
	BLENDING TUBE 450 LPM @ 11 BAR	1	UE117
	BLENDING TUBE 225 LPM @ 10 BAR	1	UE113
	BLENDING TUBE 450 LPM @ 10 BAR	1	UE114
33	3/16" BALL - 302 STAINLESS STEEL	34	V2120
34	O-RING-134	1	VO-134
35	1/4-28 X 3/16 SET SCREW	1	VT25-28SS187
36	COUPLING 1.5"NPSH	1	HM697I
	COUPLING 1.5"NH	1	HM697N
37	GASKET - 1.5" HOSE COUPLING	1	V3130
38	COUPLING 2.5"NH ROCKERLUG	1	HM677N
	COUPLING 2.5"NPSH ROCKERLUG	1	HM677I
39	GASKET - 2.5" HOSE COUPLING	1	V3190
40	CHECK SPRING	1	UE228
41	O-RING-214	1	VO-214
42	5/16-18 X 1/4 SOCKET SET SCREW	2	VT31-18SS250

Parts 11, 29, and 32 are flow calibrated as indicated by the number of grooves.



Do not intermix metering heads with eductor bodies of different flow rates. Intermixing can cause weaker or stronger foam than expected resulting in risk of injury as the ability to control the fire is compromised.

10.0 FOAM BUCKET ARRANGEMENT

The foam suction hose is matched to the eductor and must not be lengthened or foam flow will be reduced resulting in weak foam. (as shown in location D). The other three locations (A, B, & C) show the recommended foam bucket arrangement.

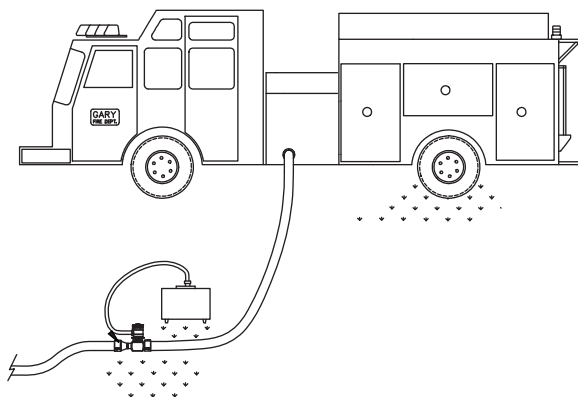

CASE A
CORRECT

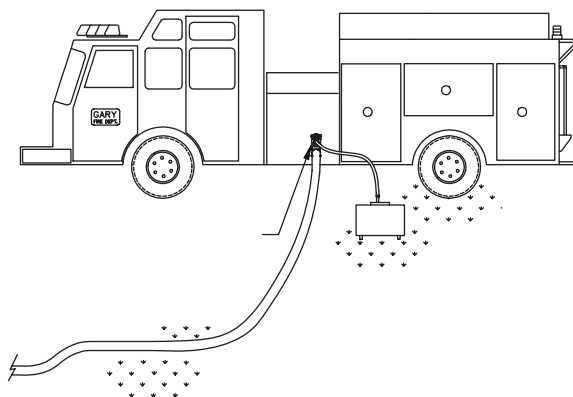

CASE B
CORRECT

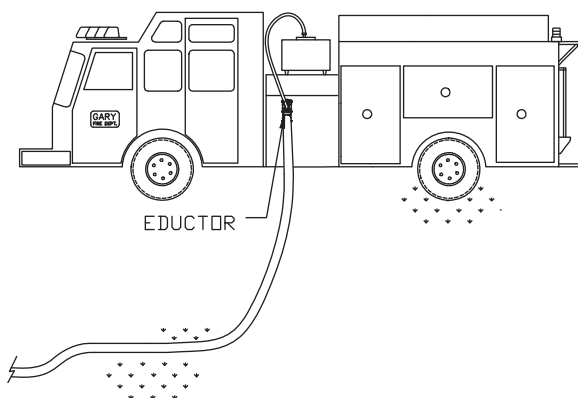

CASE C
CORRECT

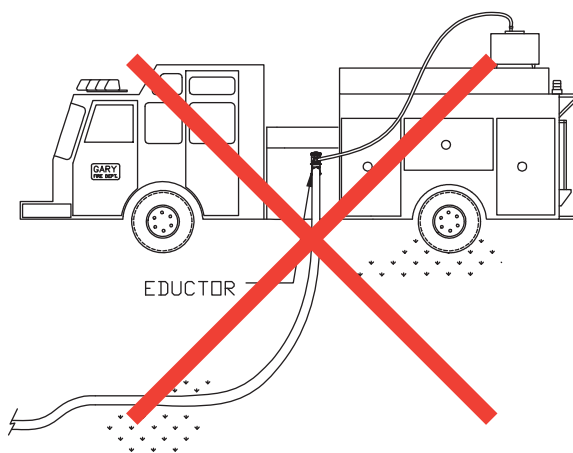

CASE D
INCORRECT

10.1 FOAM SUPPLY LOGISTICS

When using class B foams for extinguishing burning pools of liquids a continuous foam supply is essential. Foam flow may be interrupted by not changing foam buckets quickly or by switching the metering head to OFF. Foam buckets can be difficult to move or open quickly, therefore training and planning for a continuous foam supply is recommended.

⚠ DANGER

Lack of foam can place operator at risk of injury or death. Establish foam flow before advancing into hazardous situations. Make sure you do not run out of foam concentrate before the task is complete. Check concentrate level periodically and keep an adequate supply on hand.

11.0 MAINTENANCE

Eductor does not need regular maintenance. However, make sure the eductor is fully cleaned after each usage. Otherwise, the foam concentrate may dry inside and around the percentage ball resulting in plugged metering orifices. Look down inside metering head and check valve to insure clean passageways.

TASK FORCE TIPS, INC.
MADE IN USA • www.tft.com

3701 Innovation Way, Valparaiso, IN 46383-9327 USA
800-348-2686 • 219-462-6161 • Fax 219-464-7155