



VORTEX™ NOZZLE MANUAL

INSTRUCTIONS FOR INSTALLATION, SAFE OPERATION AND MAINTENANCE

⚠️ WARNING

Understand manual before use. Operation of this device without understanding the manual and receiving proper training is a misuse of this equipment. Obtain safety information at tft.com/serial-number

This instruction manual is intended to familiarize firefighters and maintenance personnel with the operation, servicing and safety procedures associated with the VORTEX fire fighting nozzles.

This manual should be kept available to all operating and maintenance personnel.

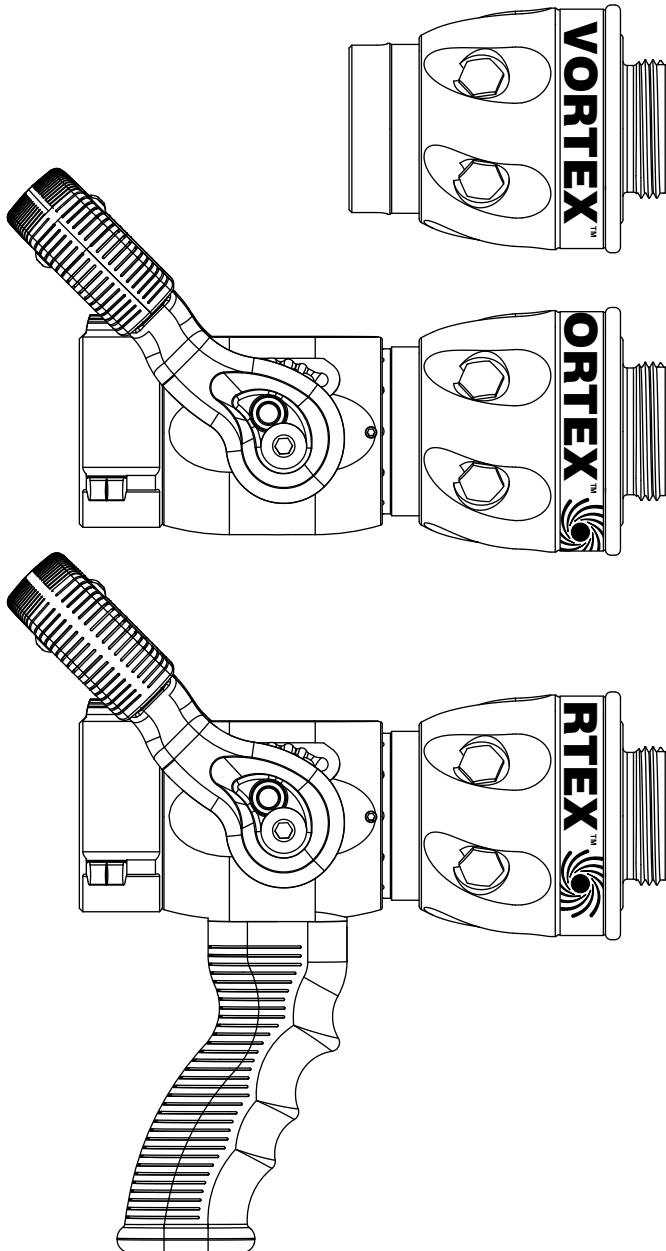

⚠️ DANGER

PERSONAL RESPONSIBILITY CODE

The member companies of FEMSA that provide emergency response equipment and services want responders to know and understand the following:

1. Firefighting and Emergency Response are inherently dangerous activities requiring proper training in their hazards and the use of extreme caution at all times.
2. It is your responsibility to read and understand any user's instructions, including purpose and limitations, provided with any piece of equipment you may be called upon to use.
3. It is your responsibility to know that you have been properly trained in Firefighting and /or Emergency Response and in the use, precautions, and care of any equipment you may be called upon to use.
4. It is your responsibility to be in proper physical condition and to maintain the personal skill level required to operate any equipment you may be called upon to use.
5. It is your responsibility to know that your equipment is in operable condition and has been maintained in accordance with the manufacturer's instructions.
6. Failure to follow these guidelines may result in death, burns or other severe injury.



Fire and Emergency Manufacturers and Service Association
P.O. Box 147, Lynnfield, MA 01940 • www.FEMSA.org

TASK FORCE TIPS LLC
MADE IN USA • tft.com





3701 Innovation Way, Valparaiso, IN 46383-9327 USA
800-348-2686 • 219-462-6161 • Fax 219-464-7155

Table Of Contents







- 1.0 MEANING OF SAFETY SIGNAL WORDS
- 2.0 SAFETY
- 3.0 GENERAL INFORMATION
 - 3.1 VARIOUS MODELS AND TERMS
 - 3.2 SPECIFICATIONS
 - 3.3 NOZZLE COUPLINGS
 - 3.4 USE WITH SALT WATER
- 4.0 FLOW CHARACTERISTICS AND CHARTS
- 5.0 NOZZLE CONTROLS
 - 5.1 FLOW CONTROL
 - 5.1.1 LEVER TYPE FLOW CONTROL
 - 5.1.2 TIP ONLY
 - 5.2 PATTERN CONTROL
- 6.0 USE WITH FOAM
- 7.0 USE OF NOZZLES
- 8.0 APPROVALS
- 9.0 COLOR CODED VALVE HANDLE AND PISTOL GRIP
- 10.0 EXPLODED VIEWS AND PARTS LISTS
- 11.0 WARRANTY
- 12.0 MAINTENANCE
 - 12.1 FIELD LUBRICATION
 - 12.2 SERVICE TESTING
 - 12.2.1 HYDROSTATIC TESTING
 - 12.2.2 FLOW TESTING
 - 12.2.3 RECORDS
 - 12.3 REPAIR
- 13.0 OPERATION AND INSPECTION CHECKLIST

1.0 MEANING OF SAFETY SIGNAL WORDS

A safety related message is identified by a safety alert symbol and a signal word to indicate the level of risk involved with a particular hazard. Per ANSI standard Z535.6-2011, the definitions of the four signal words are as follows:

	DANGER indicates a hazardous situation which, if not avoided, will result in death or serious injury.
	WARNING indicates a hazardous situation which, if not avoided, could result in death or serious injury.
	CAUTION indicates a potentially hazardous situation which, if not avoided, could result in minor or moderate injury.
	NOTICE is used to address practices not related to physical injury.

2.0 SAFETY

	An inadequate supply of nozzle pressure and/or flow will cause an ineffective stream and can result in injury, death, or loss of property. See flow graphs or call 800-348-2686 for assistance.
	The nozzle may be damaged if frozen while containing significant amounts of water. Such damage may be difficult to detect visually and can lead to possible injury or death. Any time the nozzle is subject to possible damage due to freezing, it must be tested by qualified personnel before being considered safe for use.
	This equipment is intended for use by trained personnel for firefighting. Their use for other purposes may involve hazards not addressed by this manual. Seek appropriate guidance and training to reduce risk of injury.
	Failure to restrain nozzle reaction can cause firefighter injury from loss of footing and/or stream protection. Nozzle reaction will vary as supply conditions change: such as opening or closing other nozzles, hose line kinks, changes in pump settings, etc. Changes in spray pattern or flushing will also affect nozzle reaction. The nozzle operator must always be prepared in the event of these changes.
	If nozzle gets out of control or away from operator, retreat from nozzle immediately. Do not attempt to regain control of nozzle while flowing water. Injury from whipping can occur.
	Water is a conductor of electricity. Application of water on high voltage equipment can cause injury or death by electrocution. The amount of current that may be carried back to the nozzle will depend on the following factors: <ul style="list-style-type: none">• Voltage of the line or equipment• Distance from the nozzle to the line or equipment• Size of the stream• Whether the stream is solid or broken• Purity of the water¹ <small>¹ The Fire Fighter and Electrical Equipment, The University of Michigan Extension Service, Fourth Printing 1983. Page 47</small>
	Fire streams are capable of injury and damage. Do not direct water stream to cause injury or damage to persons or property.

3.0 GENERAL INFORMATION

The TFT Vortex enhances the use of a smooth-bore nozzle. It is intended for installation behind a smooth-bore nozzle for use with water or fire fighting foam solutions. Six short vanes in the bore of the Vortex reduce turbulence in straight stream. Twisting the Stream Shaper from "STREAM" to "VORTEX" causes the vanes to pivot proportionally. This induces a gentle spin in the water to create a uniformly dispersed Vortex stream pattern. The vanes are less obtrusive than a typical stream straightener, resulting in virtually no friction loss regardless of which stream pattern is selected. The vanes also allow large debris to easily pass through the Vortex.

A 1 3/8" waterway is integrated into every Vortex 1.5" & 2.5" model. For lower flow rates, any smaller sized smooth-bore tip may be attached to the 1.5" NH male threads.

3.1 VARIOUS MODELS AND TERMS

Vortex 1.5" models are configured with 1.5"NH female threaded non-fulltime swivel couplings on the inlet and 1.5"NH male threads on the outlet for connecting to a smaller tip. Other threads are available by request. Three Vortex 1.5" models are available:

- SVFT Vortex tip-only
- SVFV Vortex with integrated detent ball valve
- SVFG Vortex with integrated detent ball valve and pistol grip

Vortex 2.5" models are configured with 2.5"NH female threaded fulltime swivel couplings on the inlet and 1.5"NH male threads on the outlet for connecting to a smaller tip. Other threads are available by request. Two Vortex 2.5" models are available:

- SVFV-NJ Vortex with integrated detent ball valve
- SVFG-NJ Vortex with integrated detent ball valve and pistol grip

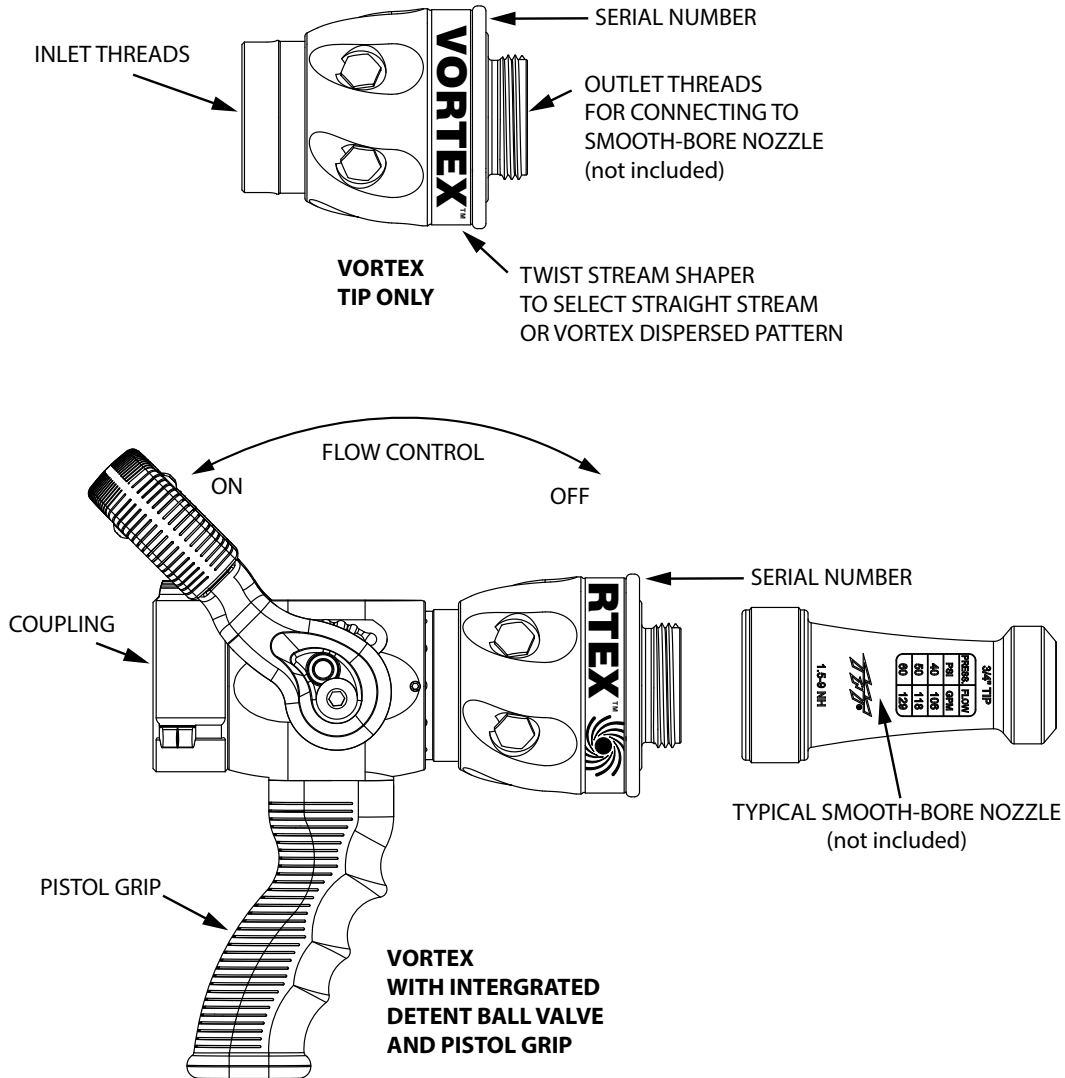

Figure 3.1 Various Models and Terms

3.2 SPECIFICATIONS

Maximum operating pressure (with valve shut off)	300 psi / 21 bar
Operating temperature range of fluid	33 to 120°F / 1 to 50° C
Stored Temperature Rating	-40 to 150°F / -40 to 65°C
Materials used	Aluminum 6000 series hard anodized MIL8625 class 3 type 2, stainless steel 300 series, nylon 6-6, nitrile rubber

3.3 NOZZLE COUPLINGS

NH (National Hose Threads per NFPA #1963) threads are standard on all nozzles. Other threads such as NPSH (National Pipe Straight Hose threads per ANSI/ASME #B1.20.7) can be specified at time of order.



Nozzle must be properly connected. Mismatched or damaged threads may cause nozzle to leak or uncouple under pressure and could cause injury.



Dissimilar metals coupled together can cause galvanic corrosion that can result in the inability to unscrew the threads or complete loss of thread engagement over time. Per NFPA 1962 (2008 edition), if dissimilar metals are left coupled together an anti-corrosive lubricant should be applied to the threads. Also, the coupling should be disconnected and inspected at least quarterly.

3.4 USE WITH SALTWATER

Use with saltwater is permissible provided nozzle is thoroughly cleaned with fresh water after each use. The service life of the nozzle may be shortened due to the effects of corrosion and is not covered under warranty.

4.0 FLOW CHARACTERISTICS AND CHARTS

The Vortex 1.5" and 2.5" have has a 1 3/8" waterway integrated into the outlet. If a smaller smooth-bore is attached to the outlet, follow the appropriate flow chart for the smaller orifice size instead.



SPECIAL CONFIGURATIONS If nozzles are made according to the special marking or performance requirements of the fire department then the operating characteristics may differ from the published data in this manual. Repair parts specific to each serial number may differ from those shown in the service procedure. The required parts for each serial number are available online by entering tft.com/H123456 with the numbers corresponding to the serial number engraved on the product.

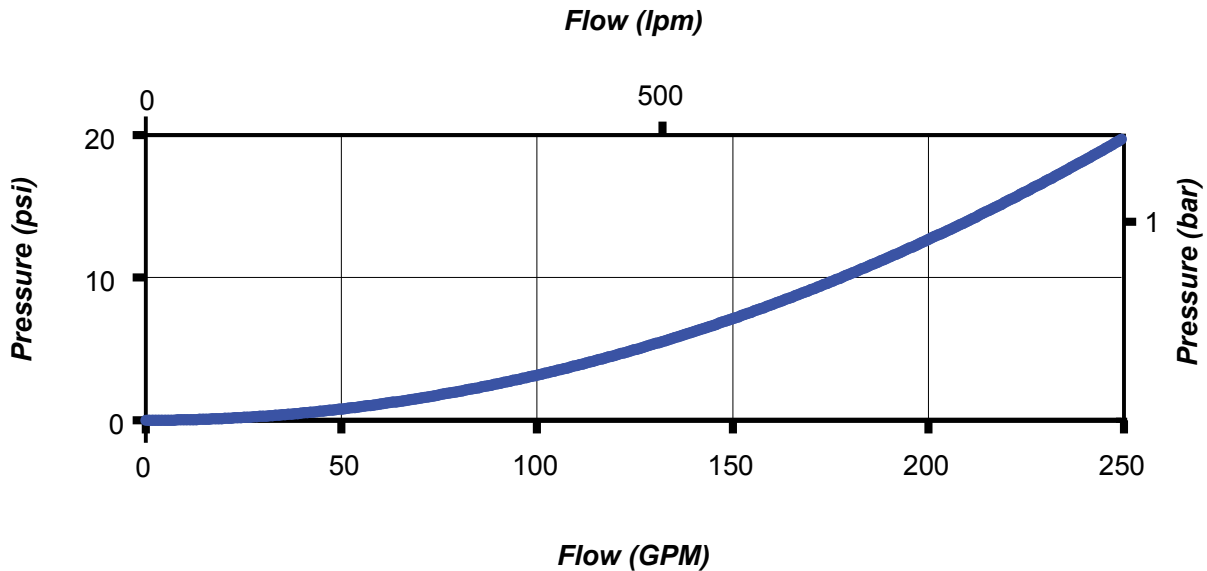

Figure 4.0
1-3/8" Waterway Flow Chart

Flows at specific pressures for each orifice size are as follows:

7/8" TIP	
PRESSURE	FLOW
PSI	GPM
40	144
50	161
60	176
70	190
80	203

15/16" TIP	
PRESSURE	FLOW
PSI	GPM
40	165
50	185
60	202
70	218
80	234

1" TIP	
PRESSURE	FLOW
PSI	GPM
40	188
50	210
60	230
70	249

1-1/16" TIP	
PRESSURE	FLOW
PSI	GPM
40	212
50	237
60	260

1-1/8" TIP	
PRESSURE	FLOW
PSI	GPM
40	238
50	266

1-3/16" TIP	
PRESSURE	FLOW
PSI	GPM
40	265
50	296

1-1/4" TIP	
PRESSURE	FLOW
PSI	GPM
40	294
50	328

1-3/8" TIP	
PRESSURE	FLOW
PSI	GPM
40	355
50	397



An inadequate supply of nozzle pressure and/or flow will cause an ineffective stream and can result in injury, death or loss of property. See flow chart in Figure 4.0 or call 800-348-2686 for assistance.

5.0 NOZZLE CONTROLS

Nozzle control valves must be opened slowly to eliminate unnecessary strain on the hose and couplings and reduce pressure surges. TFT recommends the use of a pistol grip for easier handling. For additional stress reduction, a hose rope or strap may also be used. This permits more effective use and ease of advancement, while minimizing strain and fatigue.

5.1 FLOW CONTROL

Open valve slowly to avoid sudden changes in nozzle reaction. Close valve slowly to prevent water hammer. Note: In partially open positions a ball valve will cause turbulence and adversely affect stream quality. Nozzles attached to an in-service hose shall be stored in the OFF position.

5.1.1 INTEGRATED LEVER TYPE

The integrated ball valve is shut off when the valve handle is fully forward. The valve handle has 6 detented positions to allow the nozzle operator to regulate the flow of the nozzle depending on the need or what can be safely and effectively handled.

5.1.2 TIP ONLY

Tip only nozzles have NO shut-off valve within the nozzle and MUST be used with a separate ball valve and smooth-bore tip.

5.2 PATTERN CONTROL

The TFT Vortex nozzle allows the stream pattern to be infinitely varied from a straight stream to a uniformly dispersed Vortex pattern. Typical stream results are shown in figures 5.2.1 and 5.2.2 below.



Figure 5.2.1
Straight Stream Pattern



Figure 5.2.2
Full Vortex Pattern

The Shaper includes a tactile detent at the straight stream and full Vortex dispersed positions as a secure confirmation that the desired setting has been achieved. As seen from the operating position behind the nozzle, twisting the stream shaper clockwise moves the shaper to the straight stream position shown in figure 5.2.3. Twisting the shaper counterclockwise will result in an increasingly wider pattern until reaching the full Vortex pattern shown in figure 5.2.4.

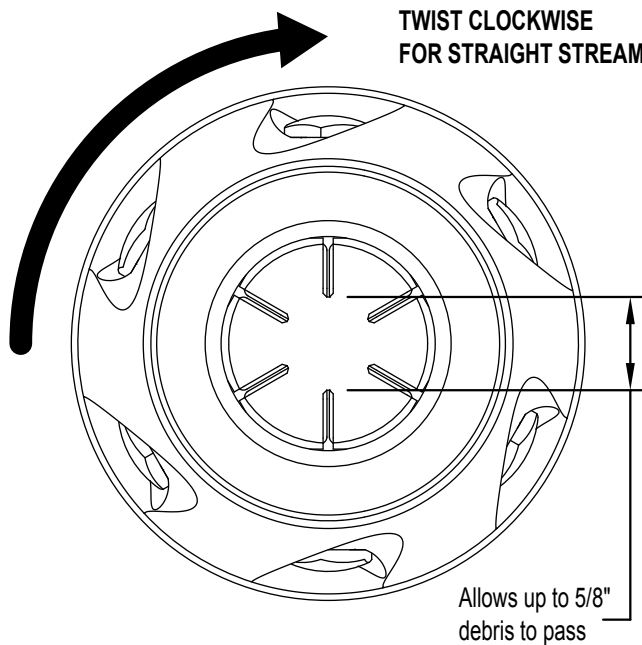

Figure 5.2.3
Straight Stream pattern setting

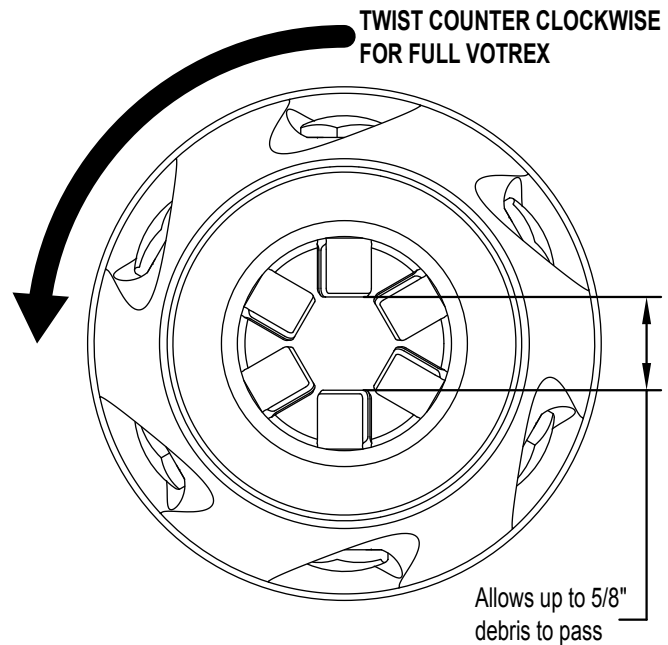

Figure 5.2.4
Full Vortex pattern setting

Pivoting the vanes has virtually no effect on the flow area or ability to pass debris up to 5/8". As a result, discharge pressure and flow rate remain constant regardless of stream pattern. The nozzle reaction is greatest when the shaper is in the straight stream position.



The nozzle operator must be prepared for a change in reaction as the pattern is changed.

6.0 USE WITH FOAM

The VORTEX with appropriate nozzle and aspiration nozzle may be used with foam solutions. Refer to fire service training for the proper use of foam.

⚠ WARNING

For Class B fires, lack of foam or interruption in the foam stream can cause a break in the foam blanket and greatly increase the risk of injury or death.

Assure that:

- Application rate is sufficient (see NFPA 11 or foam manufacturer's recommendations)
- Enough concentrate is on hand to complete task (see NFPA for minimum duration time requirements)
- Foam logistics have been carefully planned.

Allow for such things as:

- Storage of foam in a location not exposed to the hazard it protects
- Personnel, equipment, and technique to deliver foam at a rapid enough rate
- Removal of empty foam containers
- Clear path to deliver foam, as hoses, other equipment, and vehicles are deployed

⚠ WARNING

Improper use of foam can result in injury or damage to the environment. Follow foam manufacturer's instructions and fire service training to avoid:

- Using wrong type of foam on a fire, i.e. Class A foam on a Class B fire
- Plunging foam into pools of burning liquid fuels
- Causing environmental damage
- Directing stream at personnel

⚠ WARNING

There are a wide variety of foam concentrates. Each user is responsible for verifying that any foam concentrate chosen to be used with this unit has been tested to assure that the foam obtained is suitable for the purpose intended.

⚠ WARNING

Use of compressed air foam (CAF) with hand held nozzles can cause sudden surges in nozzle reaction force resulting in risk of injury or death from loss of footing or hose whipping. Be prepared for sudden changes in nozzle reaction caused by:

- Slug loading (Loss of foam concentrate sends slugs of air and water into the nozzle)
- Sudden release of built-up pressure in the hose when opening a nozzle

7.0 USE OF NOZZLES

Many factors contribute to the extinguishment of a fire. Among the most important is delivering water at a flow rate sufficient to absorb heat faster than it is being generated. The flow rate depends largely on the pump discharge pressure and hose friction loss. It can be calculated using a hydraulic equation such as:

PDP = NP + FL + DL + EL	
PDP	= Pump discharge pressure in PSI
NP	= Nozzle pressure in PSI
FL	= Hose friction loss in PSI
DL	= Device loss in PSI
EL	= Elevation loss in PSI

This manual is not intended to act as a training guide for safe fireground tactics and operations.

8.0 APPROVALS

Vortex 1.5" and 2.5" NH threaded nozzles meet the requirements of NFPA 1962 (2013) and NFPA 1964 (2008).

9.0 COLOR CODED VALVE HANDLE AND PISTOL GRIP

The TFT Vortex with integrated detent valve is supplied with black valve handle covers and pistol grips. For an additional fee, handle covers and pistol grips are available from TFT in various colors for those departments wishing to color code the nozzle to the discharge controls. A colored handle cover set will be sent upon receipt of the warranty card and color selection form by TFT. Your department's name can also be engraved on the covers (see color selection form for more information).

Handle covers are replaceable by removing the four screws that hold the handle covers in place. Use a 3/32" allen wrench when replacing screws. Pistol grip is replaceable by following TFT instruction sheet LTT-108.

For standardization NFPA 1901-2009 (A.16.9.1) recommends the following color code scheme:

Preconnect #1 or Front Bumper Jump Line	Orange	Other Colors Available: <ul style="list-style-type: none">• Pink• Tan• Purple
Preconnect #2	Red	
Preconnect #3 or discharge #1	Yellow	
Preconnect #4 or discharge #2	White	
Discharge #3	Blue	
Discharge #4	Black	
Discharge #5	Green	
Foam Lines	Red w/ White border (Red/White)	
Booster Reels	Gray	

10.0 EXPLODED VIEW AND PARTS LIST

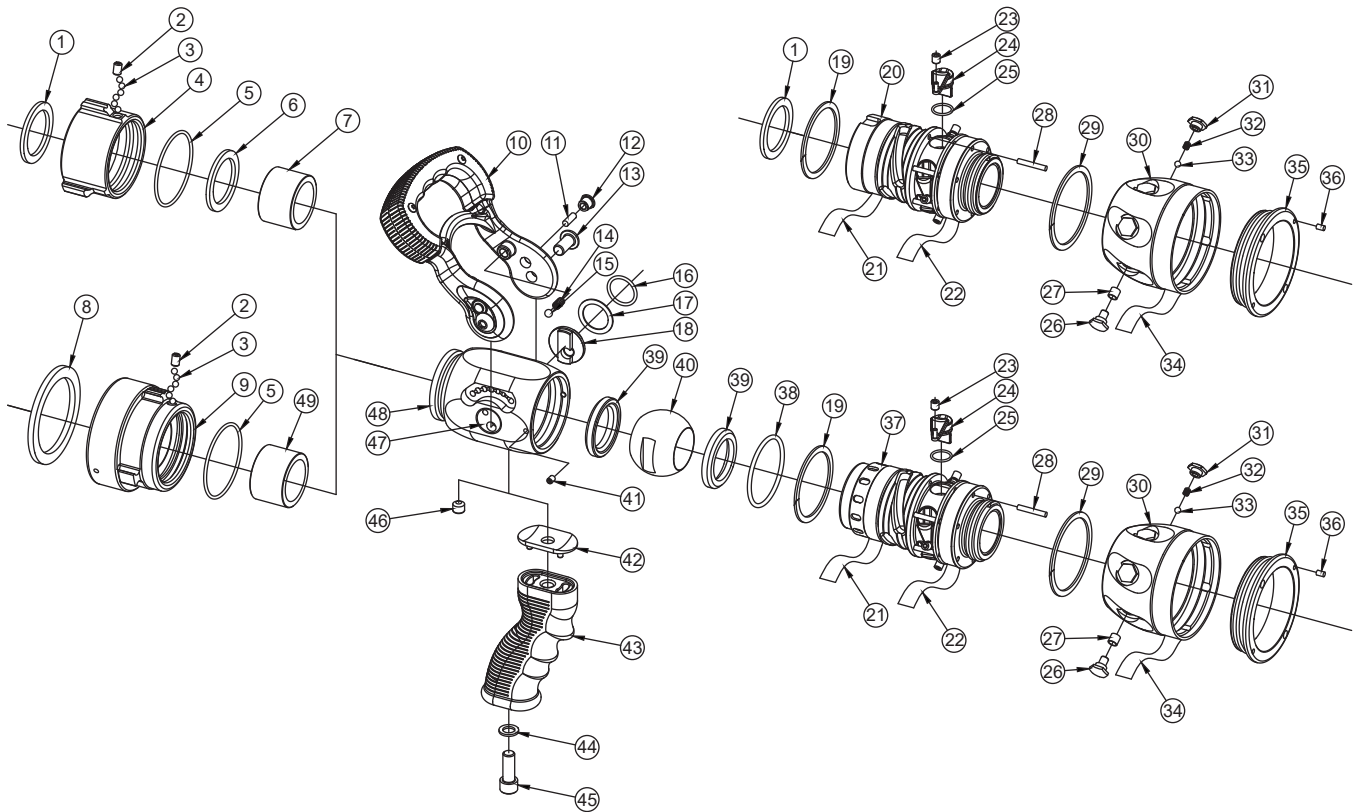

ITEM	DESCRIPTION	QTY	PART #
1	GASKET - 1.5"	1	V3130
2	1/4-28 X 1/4 SOCKET SET SCREW	1	VT25-28SS250
3	3/16" SS BALL	48	V2120
4	COUPLING 1.5" ROCKERLUG	1	H694*
5	O-RING 141	1	VO-141
6	ANTI GG RING VO	1	P147
7	REDUCTION F INSERT	1	P119F
8	GASKET - 2.5"	1	V3190
9	COUPLING 2.5"NH ROCKERLUG	1	P205N
	COUPLING 2.5"NPSH ROCKERLUG		P205I
10	HANDLE SUBASSEMBLY	1	HX920
11	3/16 X 9/16 HDP SPIROL	2	V2005
12	TRUNNION DRIVER	2	HX650
13	3/8-24 X 3/4 BUTTON HEAD	2	VT37E24BH750
14	DETENT SPRING	2	HM770
15	.243"TORLON BALL	2	VB243TO
16	O-RING-118	2	VO-118
17	TEFLON TRUNNION SHIM	2	P170
18	TRUNNION - RIGHT	1	P120R
19	BACKUP RING -330 PTFE SINGLE TURN	1	VOB-330T
20	BASE 1.5"NHF X 1.5"NHM	1	SVF100NF
21	STREAM PATTERN LABEL	1	SVF131
22	VORTEX PATTERN LABEL	1	SVF132
23	ROLLER	6	SVF114
24	VANE	6	SVF110
25	O-RING-015	6	VO-015

ITEM	DESCRIPTION	QTY	PART #
26	CAM SCREW	3	HD780
27	CAM FOLLOWER	3	SVF121
28	DOWEL PIN	6	VP156X1.00
29	BACKUP RING -332 PTFE SINGLE TURN	1	VOB-332T
30	SHAPER	1	SVF120
31	DETENT SCREW	3	HD785
32	STO DETENT SPRING	3	VM4200
33	3/16" BALL	3	V2120-TORLON
34	NAME LABEL	1	SVF130
35	RETAINER	1	SVF115
36	10-32 X 3/16 SET SCREW - NYLOK	2	VT10Y32SS187
37	BASE 1.5"NHM FOR VALVE	1	SVF101NF
38	O-RING-227	1	VO-227
39	BALL SEAT VALVE	2	P104
40	DELIN VALVE BALL	1	P103
41	10-32 X 1/4 SOCKET SET SCREW	2	VT10Y32SS250
42	GRIP SPACER HANDLINE	1	HM693-H
43	PISTOL GRIP - BLACK	1	HM692-BLK
44	WASHER	1	VM4901
45	3/8-16 X 1 SOCKET HEAD SCREW	1	VT37-16SH1.0
46	3/8-16 X 5/16 SOCKET SET SCREW	1	VT37-16SS313
47	TRUNNION - LEFT	1	P120L
48	DETENT VALVE BODY	1	P110
49	REDUCTION J INSERT	1	P119J
* - CONSULT FACTORY FOR SPECIAL THREADS			

11.0 WARRANTY

Task Force Tips LLC, 3701 Innovation Way, Valparaiso, Indiana 46383-9327 USA ("TFT") warrants to the original purchaser of its VORTEX series nozzles ("equipment"), and to anyone to whom it is transferred, that the equipment shall be free from defects in material and workmanship during the five (5) year period from the date of purchase.

TFT's obligation under this warranty is specifically limited to replacing or repairing the equipment (or its parts) which are shown by TFT's examination to be in a defective condition attributable to TFT. To qualify for this limited warranty, the claimant must return the equipment to TFT, at 3701 Innovation Way, Valparaiso, Indiana 46383-9327 USA, within a reasonable time after discovery of the defect. TFT will examine the equipment. If TFT determines that there is a defect attributable to it, TFT will correct the problem within a reasonable time. If the equipment is covered by this limited warranty, TFT will assume the expenses of repair.

If any defect attributable to TFT under this limited warranty cannot be reasonably cured by repair or replacement, TFT may elect to refund the purchase price of the equipment, less reasonable depreciation, in complete discharge of its obligations under this limited warranty. If TFT makes this election, claimant shall return the equipment to TFT free and clear of any liens and encumbrances.

This is a limited warranty. The original purchaser of the equipment, any person to whom it is transferred, and any person who is an intended or unintended beneficiary of the equipment, shall not be entitled to recover from TFT any consequential or incidental damages for injury to person and/or property resulting from any defective equipment manufactured or assembled by TFT. It is agreed and understood that the price stated for the equipment is in part consideration for limiting TFT's liability. Some states do not allow the exclusion or limitation of incidental or consequential damages, so the above may not apply to you.

TFT shall have no obligation under this limited warranty if the equipment is, or has been, misused or neglected (including failure to provide reasonable maintenance) or if there have been accidents to the equipment or if it has been repaired or altered by someone else.

THIS IS A LIMITED EXPRESS WARRANTY ONLY. TFT EXPRESSLY DISCLAIMS WITH RESPECT TO THE EQUIPMENT ALL IMPLIED WARRANTIES OF MERCHANTABILITY AND ALL IMPLIED WARRANTIES OF FITNESS FOR A PARTICULAR PURPOSE. THERE IS NO WARRANTY OF ANY NATURE MADE BY TFT BEYOND THAT STATED IN THIS DOCUMENT.

This limited warranty gives you specific legal rights, and you may also have other rights which vary from state to state.

12.0 MAINTENANCE

TFT nozzles are designed and manufactured to be damage resistant and require minimal maintenance. However, as the primary firefighting tool upon which your life depends, it should be treated accordingly. To help prevent mechanical damage, do not drop or throw equipment.

12.1 FIELD LUBRICATION

All Task Force Tip nozzles are factory lubricated with high quality silicone grease. This lubricant has excellent washout resistance and long term performance. If your department has unusually hard or sandy water, the moving parts may be affected. Foam agents and water additives contain soaps and chemicals that may break down the factory lubrication.

The moving parts of the nozzle should be checked on a regular basis for smooth and free operation, and signs of damage. IF THE NOZZLE IS OPERATING CORRECTLY, THEN NO ADDITIONAL LUBRICATION IS NEEDED. Any nozzle that is not operating correctly should be immediately removed from service.

12.2 SERVICE TESTING

In accordance with NFPA 1962 (2013), nozzles must be tested a minimum of annually. Nozzles failing any part of this test must be removed from service, repaired and retested upon completion of the repair.

12.2.1 HYDROSTATIC TESTING

Each nozzle with a shut off mechanism shall be tested in the following manner.

- 1. The nozzle shall be placed in a device capable of holding it and the shut off shall be closed.*
- 2. A device capable of exerting a hydrostatic pressure of 300 psi (2070 kPa) or 1.5 times the maximum operating pressure, whichever is higher, shall be attached to the nozzle.*
- 3. All air shall be bled from the system.*
- 4. The gage pressure shall be increased by 50 psi (3.5 bar or 345 kPa) increments, held for 30 seconds at each pressure up to the maximum pressure for which the nozzle is being tested, and then held for one minute without leakage.*
- 5. There shall be no sign of leakage through the valve or shut off.*

12.2.2 FLOW TESTING

Flow testing must be conducted in the following manner.

- 1. The nozzle shall be mounted so that the flow rate and pressure through the nozzle and the pressure at the inlet can be accurately measured.*
- 2. With the shut off fully open, the inlet pressure shall be adjusted to the rated pressure ± 2 percent.*
- 3. The valve or shut off and pattern controls shall be operated through their full range of motion at 100 psi (6.9 bar or 690 kPa) with no signs of leaking, binding or other problems.*
- 4. Evaluate the flow of nozzles as defined by NFPA 1964 in the following manner:
Basic Spray Nozzles shall flow no less than and no more than 10 percent over the rated flow at the rated pressure in the straight stream and wide-angle fog settings.*

12.2.3 RECORDS

A record of testing and repairs must be maintained from the time the nozzle is purchased until it is discarded. Each TFT nozzle is engraved with a unique serial number which, if so desired, can be used to identify nozzle for documentation purposes.

The following information, if applicable, must be included on the test record for each nozzle:

- 1. Assigned identification number*
- 2. Manufacturer*
- 3. Product or model designation*
- 4. Vendor*
- 5. Warranty*
- 6. Hose connection size*
- 7. Maximum operating pressure*
- 8. Flow rate or range*
- 9. Date received and date put in service*
- 10. Date of each service test and service test results*
- 11. Damage and repairs, including who made the repairs and the cost of repair parts*
- 12. Reason removed from service*

NFPA 1962: Standard for the care, use, inspection, service testing, and replacement of fire hose, couplings, nozzles and fire hose appliances. (2013 ed., Section 5.5.4). Quincy, MA: National Fire Protection Agency.

12.3 REPAIR

Factory service is available with repair time seldom exceeding one day in our facility. Factory-serviced nozzles are repaired by experienced technicians, wet tested to original specifications, and promptly returned. Repair charges for non-warranty items are minimal. Any returns should include a note as to the nature of the problem and whom to reach in case of questions.

Repair parts and service procedures are available for those wishing to perform their own repairs. Task Force Tips assumes no liability for damage to equipment or injury to personnel that is a result of user service. Contact the factory or visit the web site at www.tft.com for parts lists, exploded views, test procedures and troubleshooting guides. All replacement parts must be obtained from the manufacturer to assure proper operation of the product, and to maintain approval of the device.

Performance tests shall be conducted on the nozzle after a repair, or anytime a problem is reported to verify operation in accordance with TFT test procedures. Consult factory for the procedure that corresponds to the model and serial number of the nozzle. Any equipment which fails the related test criteria should be removed from service immediately. Troubleshooting guides are available with each test procedure or equipment can be returned to the factory for service and testing.



Any alterations to the nozzle and its markings could diminish safety and constitutes a misuse of this product.

13.0 OPERATION AND INSPECTION CHECKLIST

BEFORE EACH USE the nozzle must be inspected to this checklist:

- 1) There is no obvious damage such as missing, broken or loose parts, damaged labels etc.
- 2) Internal vanes are free of debris
- 3) Coupling is tight and leak free
- 4) Valve operates freely through full range and regulates flow
- 5) "OFF" position does fully shut off and flow is stopped
- 6) Nozzle flow is adequate as indicated by pump pressure and nozzle reaction
- 7) Shaper turns freely and adjusts pattern through full range
- 8) Shaper detent (if so equipped) operates smoothly and positively.

BEFORE BEING PLACED BACK IN SERVICE, nozzles must be inspected to this checklist;

- 1) *All controls and adjustments are operational*
- 2) *Shut off valve (if so equipped) closes off the flow completely*
- 3) *There are no broken or missing parts*
- 4) *There is no damage to the nozzle that could impair safe operation (e.g. dents, cracks, corrosion or other defects)*
- 5) *The thread gasket is in good condition*
- 6) *The waterway is clear of obstructions*
- 7) *Nozzle is clean and markings are legible*
- 8) *Coupling is retightened properly*
- 9) *Shaper is set to desired pattern*
- 10) *Shutoff handle is stored in the OFF position*

NFPA 1962: Standard for the care, use, inspection, service testing, and replacement of fire hose, couplings, nozzles and fire hose appliances. (2013 ed., Section 5.2.2). Quincy, MA: National Fire Protection Agency.



Any nozzle failing any part of the checklist is unsafe for use and must have the problem corrected before use or being placed back into service. Operating a nozzle that has failed the checklist is a misuse of this equipment.