



MANUAL: Hand Held Automatic Dual Pressure Nozzles

Mid-Force, CAFS-Force and Dual-Force

INSTRUCTIONS FOR SAFE OPERATION AND MAINTENANCE

⚠ WARNING

Understand manual before use. Operation of this device without understanding the manual and receiving proper training is a misuse of this equipment. Obtain safety information at www.tft.com/serial-number

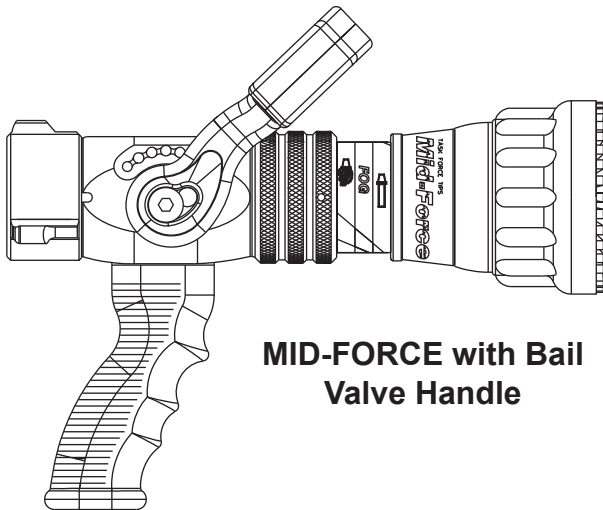

**MID-FORCE with Bail
Valve Handle**

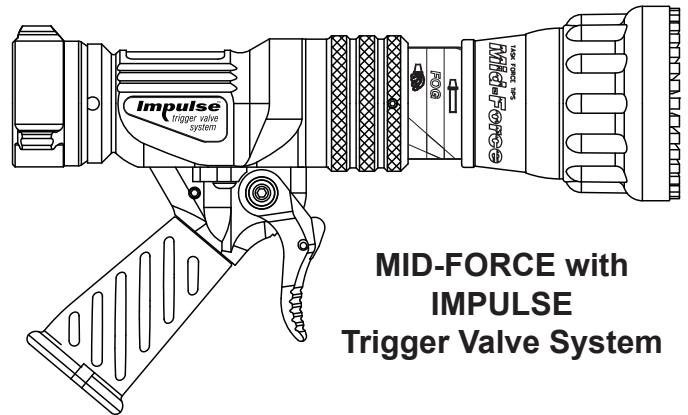

**MID-FORCE with
IMPULSE
Trigger Valve System**

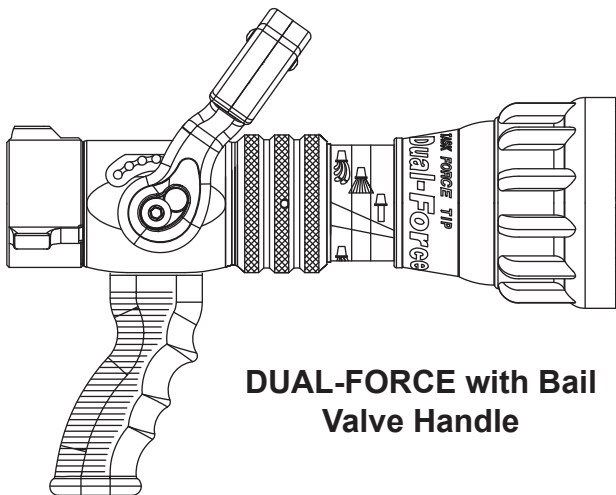

**DUAL-FORCE with Bail
Valve Handle**

⚠ DANGER

PERSONAL RESPONSIBILITY CODE

The member companies of FEMSA that provide emergency response equipment and services want responders to know and understand the following:

1. Firefighting and Emergency Response are inherently dangerous activities requiring proper training in their hazards and the use of extreme caution at all times.
2. It is your responsibility to read and understand any user's instructions, including purpose and limitations, provided with any piece of equipment you may be called upon to use.
3. It is your responsibility to know that you have been properly trained in Firefighting and /or Emergency Response and in the use, precautions, and care of any equipment you may be called upon to use.
4. It is your responsibility to be in proper physical condition and to maintain the personal skill level required to operate any equipment you may be called upon to use.
5. It is your responsibility to know that your equipment is in operable condition and has been maintained in accordance with the manufacturer's instructions.
6. Failure to follow these guidelines may result in death, burns or other severe injury.



Fire and Emergency Manufacturers and Service Association
P.O. Box 147, Lynnfield, MA 01940 • www.FEMSA.org

TASK FORCE TIPS, INC.
MADE IN USA • www.tft.com

3701 Innovation Way, Valparaiso, IN 46383-9327 USA
800-348-2686 • 219- 462-6161 • Fax 219-464-7155

Table Of Contents

- 1.0 MEANING OF SAFETY SIGNAL WORDS
- 2.0 SAFETY
- 3.0 GENERAL INFORMATION
 - 3.1 VARIOUS MODELS AND TERMS
 - 3.2 SPECIFICATIONS
 - 3.2.1 MECHANICAL
 - 3.3 NOZZLE COUPLINGS
 - 3.4 USE WITH SALT WATER
- 4.0 FLOW CHARACTERISTICS
 - 4.1 FLOW GRAPHS
 - 4.2 FLOW AND REACTION CHARTS
 - 4.3 REACH AND TRAJECTORY
- 5.0 NOZZLE CONTROLS
 - 5.1 FLOW CONTROL
 - 5.1.1 LEVER TYPE FLOW CONTROL
 - 5.1.2 TIP ONLY
 - 5.1.3 BALL SHUT-OFF
 - 5.1.4 TWIST SHUT-OFF
 - 5.1.5 IMPULSE TRIGGER FLOW CONTROL
 - 5.1.5.1 IMPULSE TRIGGER LOCK
 - 5.1.5.2 TRIGGER FLOW CONTROL SPEED ADJUSTMENT
 - 5.1.5.3 NORMAL OPERATING POSITION
 - 5.2 PATTERN CONTROL ADJUSTMENT
 - 5.2.1 PATTERN CONTROL
 - 5.2.2 FLUSH CONTROL
 - 5.3 STANDARD/LOW PRESSURE KNOB MID-FORCE & DUAL-FORCE
- 6.0 USE WITH FOAM
 - 6.1 FOAM ASPIRATING ATTACHMENTS
- 7.0 USE OF NOZZLES
 - 7.1 MID-FORCE AND DUAL-FORCE NOZZLES
 - 7.2 CAFS-FORCE 1 AND CAFS-FORCE 2 NOZZLES
- 8.0 APPROVALS
- 9.0 COLOR CODED VALVE HANDLE AND PISTOL GRIP
 - 9.1 IMPULSE TRIGGER VALVE SYSTEM NOZZLE COLORED PISTOL GRIPS
- 10.0 WARRANTY
- 11.0 MAINTENANCE
 - 11.1 FIELD LUBRICATION
 - 11.2 IMPULSE TRIGGER VALVE LUBRICATION
 - 11.3 SERVICE TESTING
 - 11.3.1 HYDROSTATIC TESTING
 - 11.3.2 FLOW TESTING
 - 11.3.3 RECORDS
 - 11.4 REPAIR
- 12.0 OPERATION and INSPECTION CHECKLIST

1.0 MEANING OF SAFETY SIGNAL WORDS

A safety related message is identified by a safety alert symbol and a signal word to indicate the level of risk involved with a particular hazard. Per ANSI standard Z535.6-2011, the definitions of the four signal words are as follows:



DANGER indicates a hazardous situation which, if not avoided, will result in death or serious injury.



WARNING indicates a hazardous situation which, if not avoided, could result in death or serious injury.



CAUTION indicates a potentially hazardous situation which, if not avoided, could result in minor or moderate injury.



NOTICE is used to address practices not related to physical injury.

2.0 SAFETY



An inadequate supply of nozzle pressure and/or flow will cause an ineffective stream and can result in injury, death, or loss of property. See flow graphs or call 800-348-2686 for assistance.



The nozzle may be damaged if frozen while containing significant amounts of water. Such damage may be difficult to detect visually and can lead to possible injury or death. Any time the nozzle is subject to possible damage due to freezing, it must be tested by qualified personnel before being considered safe for use.



This equipment is intended for use by trained personnel for firefighting. Their use for other purposes may involve hazards not addressed by this manual. Seek appropriate guidance and training to reduce risk of injury.



Failure to restrain nozzle reaction can cause firefighter injury from loss of footing and/or stream protection. Nozzle reaction will vary as supply conditions change: such as opening or closing other nozzles, hose line kinks, changes in pump settings, etc. Changes in spray pattern or flushing will also affect nozzle reaction. The nozzle operator must always be prepared in the event of these changes.



If nozzle gets out of control or away from operator, retreat from nozzle immediately. Do not attempt to regain control of nozzle while flowing water. Injury from whipping can occur.



Water is a conductor of electricity. Application of water on high voltage equipment can cause injury or death by electrocution. The amount of current that may be carried back to the nozzle will depend on the following factors:

- Voltage of the line or equipment
- Distance from the nozzle to the line or equipment
- Size of the stream
- Whether the stream is solid or broken
- Purity of the water¹

¹ The Fire Fighter and Electrical Equipment, The University of Michigan Extension Service, Fourth Printing 1983. Page 47



Fire streams are capable of injury and damage. Do not direct water stream to cause injury or damage to persons or property.

3.0 GENERAL INFORMATION

The Task Force Tips nozzles are designed to provide excellent performance under most firefighting conditions. Their rugged construction is compatible with the use of fresh water as well as firefighting foam solutions. Other important operating features are:

- Switchable from standard operation to low pressure
- Automatic pressure regulation (meets NFPA 1964 automatic nozzle pressure requirements)
- Slide valve for excellent stream quality at all valve positions
- Quick-acting pattern control from straight stream to wide fog
- “Power fog teeth” for full-fill fog
- “Gasket grabber” inlet screen to keep large debris from entering nozzle
- Easily flushable while flowing to clear trapped debris
- TFT’s five-year warranty and unsurpassed customer service

3.1 VARIOUS MODELS AND TERMS

The nozzle is available in several different models and inlet connections. Basic body styles are shown in figure 3.1A

| SERIES | FLOW RANGE | | NOMINAL PRESSURE | | STANDARD COUPLING* |
|-------------|------------|----------|------------------|-----|--------------------|
| | GPM | L/min | PSI | BAR | |
| MID-FORCE | 70-200 | 265-760 | 100 | 7 | 1-1/2 NH |
| MID-FORCE | 70-200 | 265-760 | 75 | 5 | 1-1/2 NH |
| DUAL-FORCE | 95-300 | 360-1150 | 100 | 7 | 1-1/2 NH |
| DUAL-FORCE | 95-300 | 360-1150 | 75 | 5 | 1-1/2 NH |
| CAFS-FORCE1 | 70-200 | 265-760 | 75 | 5 | 1-1/2 NH |
| CAFS-FORCE2 | 95-250 | 360-950 | 75 | 5 | 1-1/2 NH |

* Other threads, coupling sizes, or connector styles can be specified at time of order.

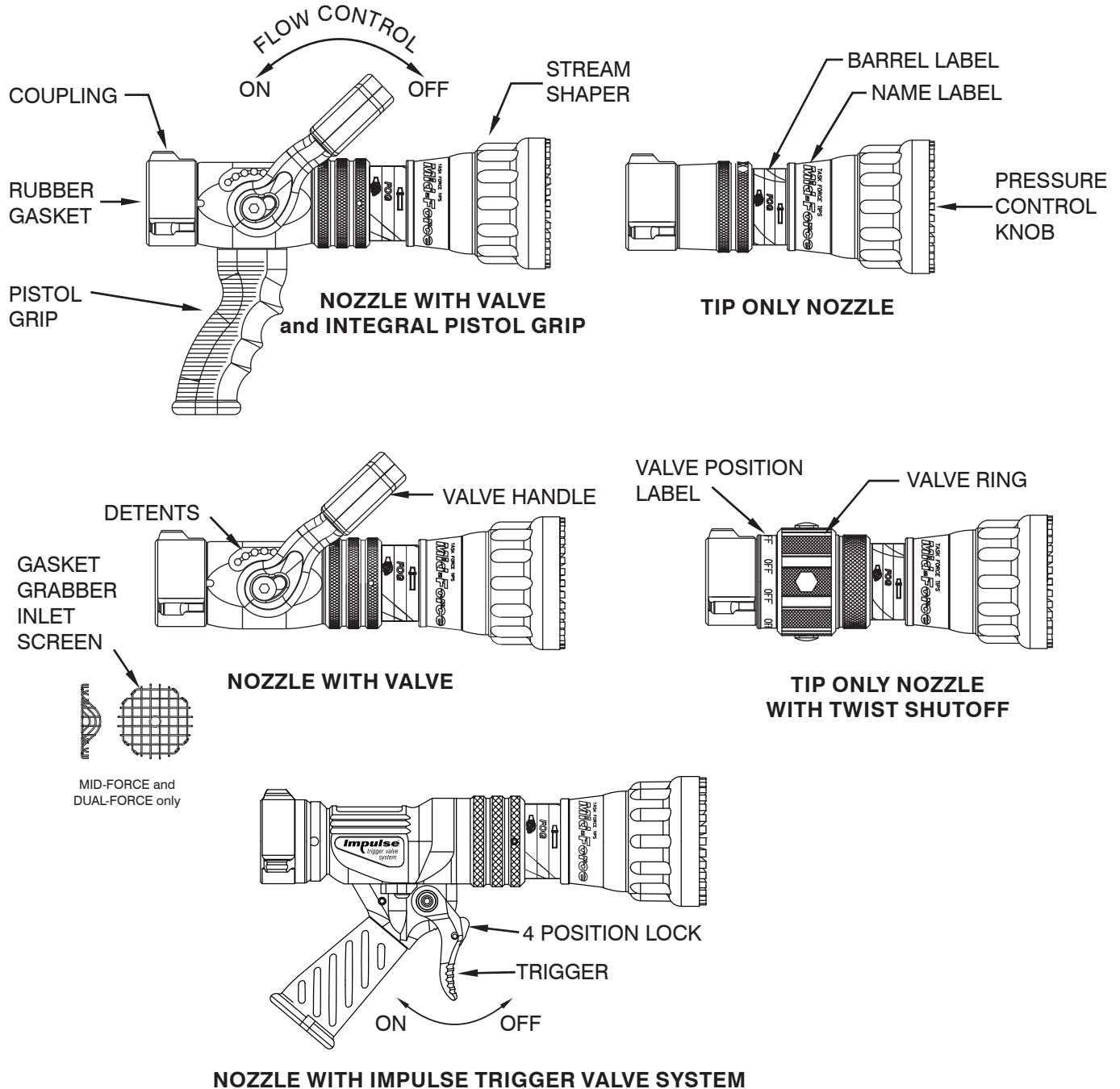

3.1A COMMON MODELS AND TERMS

3.2 SPECIFICATIONS

3.2.1 MECHANICAL

| | | |
|--|--|--------------|
| Maximum nozzle inlet pressure with valve shutoff | 300 psi | 21 bar |
| Operating temperature range of fluid | 33 to 120° F | 1 to 50° C |
| Storage temperature range | -40 to 150° F | -40 to 65° C |
| Materials used | Aluminum 6000 series hard anodized MIL8625 class 3 type 2, stainless steel 300 series, nylon 6-6, nitrile rubber | |

3.3 NOZZLE COUPLINGS

Many inlet couplings such as NH (National Hose) or NPSH (National Pipe Straight Hose) can be specified at time of order.



Nozzle must be mated to a hose line with matched threads. Mismatched or damaged threads may cause nozzle to leak or uncouple under pressure and could cause injury.



Dissimilar metals coupled together can cause galvanic corrosion that can result in the inability to unscrew the threads or complete loss of thread engagement over time. Per NFPA 1962, if dissimilar metals are left coupled together an anti-corrosive lubricant should be applied to the threads. Also the coupling should be disconnected and inspected at least quarterly.

3.4 USE WITH SALT WATER

Use with saltwater is permissible provided nozzle is thoroughly cleaned with fresh water after each use. The service life of the nozzle may be shortened due to the effects of corrosion and is not covered under warranty.

4.0 FLOW CHARACTERISTICS

The following graphs show the typical performance of MID-FORCE, CAFS-FORCE and DUAL-FORCE nozzles.

SPECIAL CONFIGURATIONS - If nozzles are made according to the special marking or performance requirements of the fire department then the operating characteristics may differ from the published data in this manual. Repair parts specific to each serial number may differ from those shown in the service procedure. The required parts for each serial number are available on-line by entering www.tft.123456 with the numbers corresponding to the serial number engraved on the product.

4.1 FLOW GRAPHS

Mid-Force meets NFPA flow requirements.

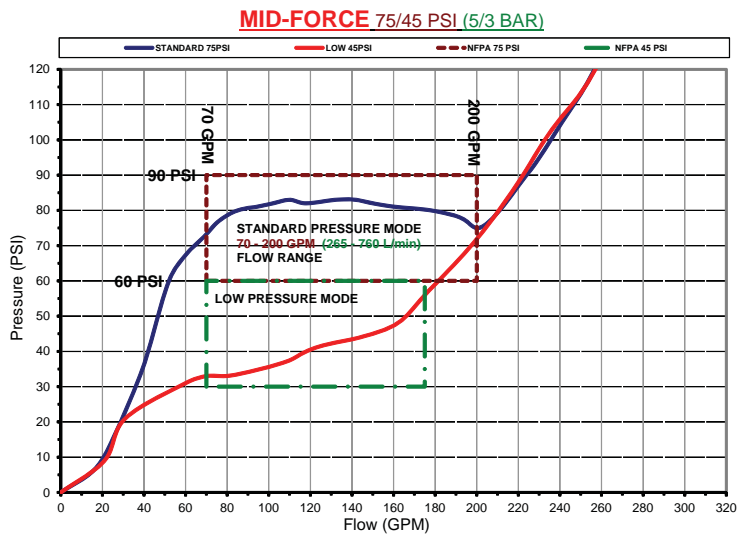
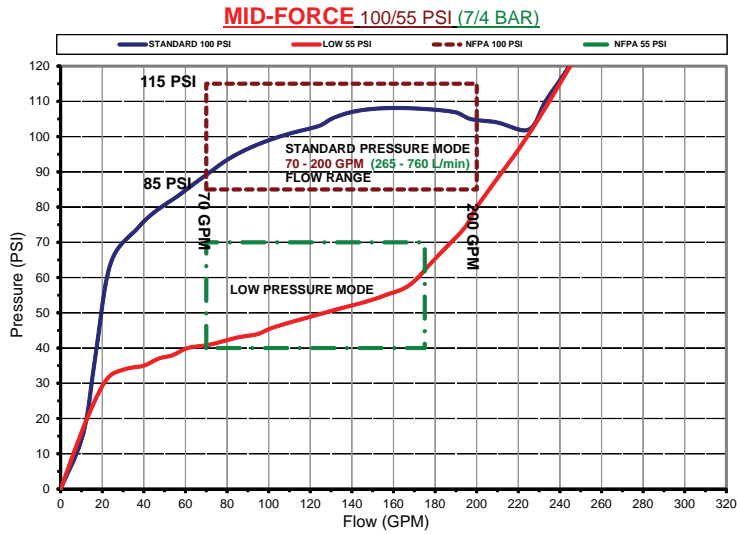

CAFS-Force 1

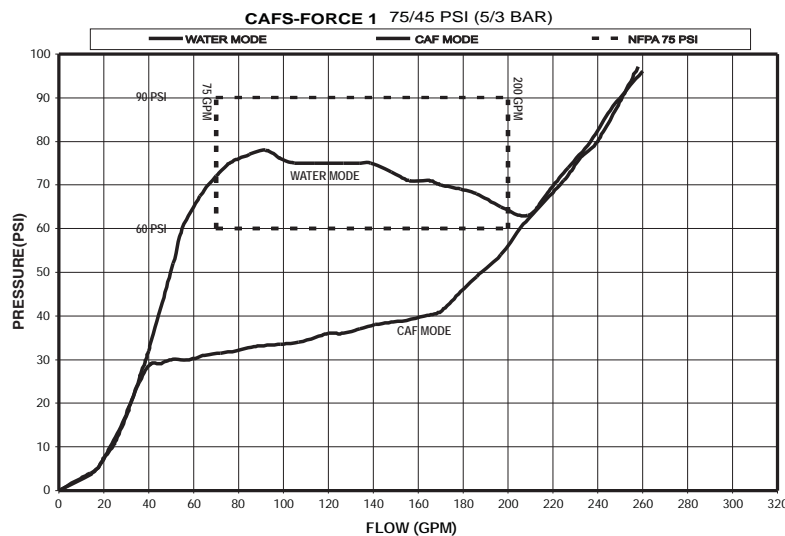

The charts in section 4.2 of this document give specific examples of maximum flow rates for particular situations. Friction losses may vary due to differences in hose construction resulting in flows different than those shown. For situations or lengths of hose not listed on the chart, approximate flows can be calculated using conventional hydraulics. NOTE: Within the flow range, the nozzle inlet pressure may be approximated to be 100 or 75 PSI, when used in the standard pressure mode, and 55 or 45 PSI in low pressure mode.

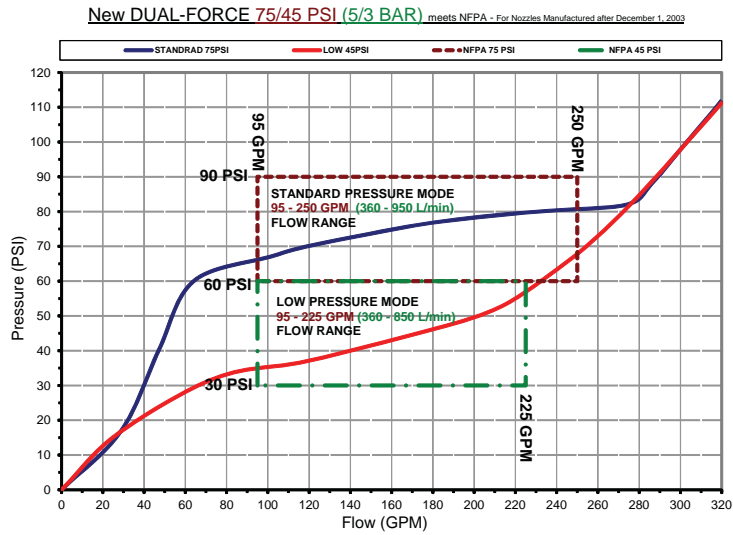
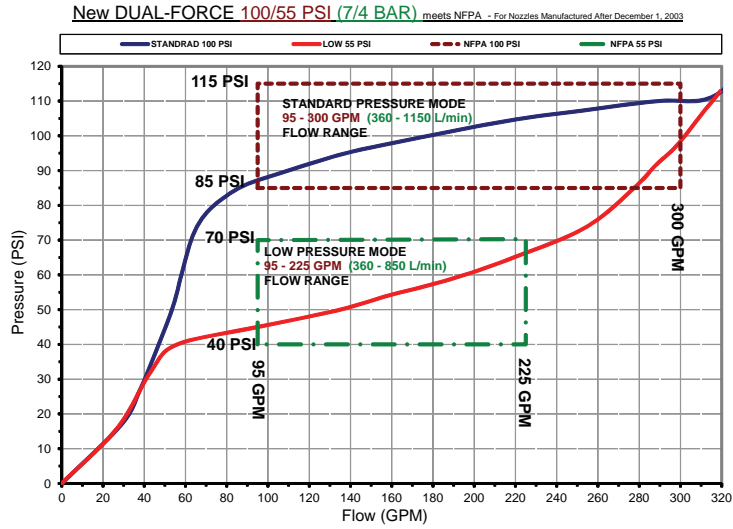

CAFS-Force 2

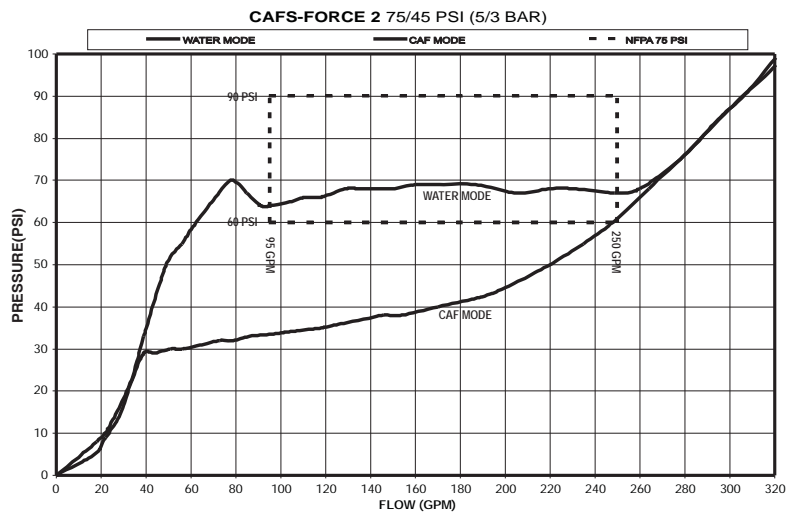

FIGURE 3 - NOZZLE PERFORMANCE
(on pages 6 - 7)

Mid-Force 100/55 PSI

STD = STANDARD PRESSURE MODE
LP = LOW PRESSURE MODE

Flow And Nozzle Reaction Chart

| FLOW (GPM) REACTION (LBS) | 1 1/2" HOSE | | | | | | 1 3/4" HOSE | | | | | | 2" HOSE | | | | | |
|---------------------------------|-------------|-----------|-----------|-----------|-----------|-----------|-------------|------------|------------|------------|------------|-----------|------------|-----------|------------|-----------|------------|-----------|
| | 150 ft. | | 200 ft. | | 250 ft. | | 150 ft. | | 200 ft. | | 250 ft. | | 150 ft. | | 200 ft. | | 250 ft. | |
| | STD | LP | STD | LP | STD | LP | STD | LP | STD | LP | STD | LP | STD | LP | STD | LP | STD | LP |
| 50 | 21 8 | 55 17 | 21 7 | 50 16 | 21 7 | 46 14 | 21 8 | 65 21 | 21 8 | 60 19 | 21 7 | 54 17 | 22 8 | 82 27 | 22 8 | 75 24 | 22 8 | 68 22 |
| 75 | 31 13 | 93 31 | 29 12 | 83 27 | 28 12 | 75 24 | 32 14 | 111 38 | 32 14 | 100 33 | 31 13 | 91 30 | 36 15 | 141 51 | 35 15 | 128 45 | 34 15 | 119 41 |
| 100 | 65 30 | 121 42 | 59 27 | 107 36 | 55 25 | 97 32 | 72 34 | 143 52 | 72 34 | 129 45 | 67 32 | 117 40 | 84 41 | 184 72 | 79 38 | 167 63 | 75 36 | 153 56 |
| 125 | 93 45 | 143 52 | 84 40 | 126 44 | 77 37 | 114 39 | 108 54 | 172 65 | 108 54 | 152 56 | 97 48 | 138 50 | 135 69 | 213 90 | 122 62 | 198 79 | 113 57 | 182 70 |
| 150 | 117 59 | 163 61 | 105 52 | 143 52 | 96 47 | 130 46 | 141 72 | 195 77 | 141 72 | 174 66 | 125 63 | 158 58 | 196 101 | --- | 168 87 | 220 95 | 151 78 | 205 84 |
| 175 | 140 72 | 180 69 | 124 63 | 159 59 | 112 57 | 143 52 | 174 90 | 213 90 | 174 90 | 192 76 | 151 78 | 175 66 | --- | --- | 212 109 | --- | 187 97 | 223 98 |
| 200 | 162 84 | 196 78 | 141 73 | 173 66 | 128 65 | 156 58 | 204 105 | 228 102 | 204 105 | 207 86 | 175 91 | 189 75 | --- | --- | --- | --- | 222 113 | --- |
| 225 | 183 94 | 209 87 | 158 82 | 186 72 | 142 73 | 168 63 | --- | --- | --- | 198 102 | 198 102 | 203 83 | --- | --- | --- | --- | --- | --- |

CAUTION: Changing to Low Pressure mode will typically increase nozzle reaction.

(1) Number on top in each box indicates flow (GPM), and number on bottom indicates nozzle reaction (LBS). (2) In Standard mode, the average nozzle pressure is 100 PSI. (3) Flows may vary with brand or condition of hose. (4) Flows are approximate and do not reflect losses in preconnect piping.

Mid-Force 7/4 BAR

Flow And Nozzle Reaction Chart

7 bar = STANDARD PRESSURE MODE
LP = LOW PRESSURE MODE

| FLOW (LPM) REACTION (KG) | 38mm HOSE | | | | | | 45mm HOSE | | | | | | 50mm HOSE | | | | | |
|--------------------------------|-----------|-----------|-----------|-----------|-----------|-----------|-----------|-----------|-----------|-----------|-----------|-----------|------------|-----------|-----------|-----------|-----------|-----------|
| | 45M | | 60M | | 75M | | 45M | | 60M | | 75M | | 45M | | 60M | | 75M | |
| | 7 bar | LP | 7 bar | LP | 7 bar | LP | 7 bar | LP | 7 bar | LP | 7 bar | LP | 7 bar | LP | 7 bar | LP | 7 bar | LP |
| 3.5 | 80 4 | 210 8 | 80 3 | 190 7 | 80 3 | 175 6 | 80 4 | 245 10 | 80 4 | 225 9 | 80 3 | 205 8 | 85 4 | 310 12 | 85 4 | 285 11 | 85 4 | 225 10 |
| 5.2 | 115 6 | 350 14 | 110 5 | 315 12 | 105 5 | 285 11 | 85 6 | 420 17 | 120 6 | 380 15 | 115 6 | 345 14 | 135 175 | 535 23 | 130 7 | 485 20 | 130 7 | 450 19 |
| 7.0 | 245 14 | 460 19 | 225 12 | 405 16 | 210 11 | 365 15 | 275 15 | 540 24 | 255 15 | 490 20 | 240 13 | 445 18 | 320 19 | 695 33 | 300 17 | 630 29 | 300 17 | 580 25 |
| 8.6 | 350 20 | 540 24 | 320 18 | 475 20 | 290 17 | 430 18 | 410 25 | 650 30 | 365 22 | 575 25 | 345 20 | 520 23 | 510 31 | 805 41 | 460 28 | 750 36 | 430 26 | 690 32 |
| 10.0 | 445 27 | 615 28 | 395 24 | 540 24 | 365 21 | 490 21 | 535 33 | 740 35 | 475 29 | 660 30 | 430 26 | 600 26 | 740 46 | --- | 635 40 | --- | 570 35 | 775 38 |
| 12.0 | 530 33 | 680 31 | 470 29 | 600 27 | 425 26 | 540 24 | 660 41 | 805 41 | 570 35 | 725 35 | 515 32 | 660 30 | --- | --- | 800 50 | --- | 710 44 | 845 45 |
| 14.0 | 615 38 | 740 35 | 535 33 | 655 30 | 485 30 | 590 26 | 770 48 | --- | 660 41 | 785 39 | 595 37 | 715 34 | --- | --- | --- | --- | 840 51 | --- |
| 15.5 | 695 43 | 790 40 | 600 37 | 705 33 | 535 33 | 635 29 | --- | --- | 750 46 | 835 44 | 665 41 | 770 38 | --- | --- | --- | --- | --- | --- |

CAUTION: Changing to Low Pressure mode will typically increase nozzle reaction.

(1) Number on top in each box indicates flow (LPM), and number on bottom indicates nozzle reaction (KG). (2) In Standard mode, the average nozzle pressure is 7 bar. (3) Flows may vary with brand or condition of hose. (4) Flows are approximate and do not reflect losses in preconnect piping.

Mid-Force 75/45 PSI

Flow And Nozzle Reaction Chart

STD = STANDARD PRESSURE MODE
LP = LOW PRESSURE MODE

| FLOW (GPM) REACTION (LBS) | 1 1/2" HOSE | | | | | | 1 3/4" HOSE | | | | | | 2" HOSE | | | | | |
|---------------------------------|-------------|-----------|-----------|-----------|-----------|-----------|-------------|------------|-----------|-----------|-----------|-----------|-----------|-----------|-----------|-----------|-----------|-----------|
| | 150 ft. | | 200 ft. | | 250 ft. | | 150 ft. | | 200 ft. | | 250 ft. | | 150 ft. | | 200 ft. | | 250 ft. | |
| | STD | LP | STD | LP | STD | LP | STD | LP | STD | LP | STD | LP | STD | LP | STD | LP | STD | LP |
| 50 | 43 14 | 69 20 | 43 14 | 62 18 | 42 13 | 57 16 | 45 15 | 84 25 | 44 15 | 74 21 | 43 14 | 67 19 | 45 15 | 84 25 | 45 16 | 97 29 | 45 15 | 89 26 |
| 75 | 55 22 | 104 32 | 53 21 | 92 27 | 51 20 | 83 24 | 59 24 | 121 39 | 57 23 | 110 34 | 55 22 | 101 30 | 64 27 | 155 53 | 62 26 | 140 47 | 60 25 | 128 42 |
| 100 | 78 35 | 127 42 | 72 32 | 113 35 | 68 29 | 103 31 | 91 41 | 153 52 | 82 37 | 136 45 | 77 34 | 123 40 | 122 56 | 182 71 | 105 48 | 171 63 | 97 44 | 162 56 |
| 125 | 108 50 | 149 50 | 96 43 | 131 43 | 86 39 | 119 38 | 134 62 | 174 65 | 118 54 | 159 55 | 105 48 | 145 48 | 203 89 | 204 89 | 166 75 | 192 79 | 146 67 | 181 70 |
| 150 | 136 63 | 166 60 | 119 54 | 148 50 | 106 49 | 134 44 | 173 78 | 191 78 | 148 68 | 174 66 | 132 60 | 162 57 | ó ó | ó ó | 210 95 | 210 95 | 189 85 | 199 85 |
| 175 | 162 73 | 180 70 | 138 64 | 163 57 | 124 57 | 147 50 | 206 91 | 206 91 | 175 79 | 189 77 | 155 71 | 175 66 | ó ó | ó ó | ó ó | ó ó | 215 99 | 214 99 |
| 200 | 183 82 | 192 79 | 157 72 | 174 65 | 140 64 | 160 55 | 220 104 | 220 104 | 201 88 | 202 87 | 176 80 | 188 76 | ó ó | ó ó | ó ó | ó ó | ó ó | ó ó |
| 225 | 204 90 | 204 89 | 174 79 | 184 73 | 155 71 | 170 62 | --- --- | --- --- | 214 98 | 214 98 | 196 86 | 199 85 | ó --- | ó --- | ó --- | ó --- | ó --- | ó --- |

CAUTION: Changing to Low Pressure mode will typically increase nozzle reaction.

(1) Number on top in each box indicates flow (GPM), and number on bottom indicates nozzle reaction (LBS). (2) In Standard mode, the average nozzle pressure is 100 PSI. (3) Flows may vary with brand or condition of hose. (4)

Mid-Force 5/3 BAR

Flow And Nozzle Reaction Chart

7 bar = STANDARD PRESSURE MODE
LP = LOW PRESSURE MODE

| FLOW (LPM) REACTION (KG) | 38mm HOSE | | | | | | 45mm HOSE | | | | | | 50mm HOSE | | | | | |
|--------------------------------|-----------|-----------|-----------|-----------|-----------|-----------|-----------|-----------|-----------|-----------|-----------|-----------|-----------|-----------|-----------|-----------|-----------|-----------|
| | 45M | | 60M | | 75M | | 45M | | 60M | | 75M | | 45M | | 60M | | 75M | |
| | 5 bar | LP | 5 bar | LP | 5 bar | LP | 5 bar | LP | 5 bar | LP | 5 bar | LP | 5 bar | LP | 5 bar | LP | 5 bar | LP |
| 3.5 | 163 6 | 261 9 | 163 6 | 235 8 | 159 6 | 216 7 | 170 7 | 318 11 | 167 7 | 280 10 | 163 6 | 254 9 | 170 7 | 318 11 | 170 7 | 367 13 | 170 7 | 337 12 |
| 5.2 | 208 10 | 394 15 | 193 9 | 348 12 | 193 9 | 314 11 | 223 11 | 458 18 | 216 12 | 416 15 | 208 10 | 382 14 | 242 12 | 587 24 | 235 12 | 530 21 | 227 11 | 484 19 |
| 7.0 | 295 16 | 481 19 | 257 13 | 428 16 | 257 13 | 390 14 | 344 19 | 579 24 | 310 19 | 515 20 | 291 15 | 466 18 | 462 25 | 689 32 | 397 22 | 647 29 | 367 20 | 613 25 |
| 8.6 | 409 23 | 564 23 | 326 18 | 496 20 | 326 18 | 450 17 | 507 28 | 659 29 | 447 25 | 602 25 | 397 22 | 549 22 | 768 40 | 772 40 | 628 34 | 727 36 | 553 30 | 685 32 |
| 10.0 | 515 29 | 628 27 | 401 22 | 560 23 | 401 22 | 507 20 | 655 35 | 723 35 | 560 31 | 659 30 | 500 27 | 613 26 | 613 26 | 613 26 | 795 43 | 795 43 | 715 39 | 753 39 |
| 12.0 | 613 33 | 681 32 | 469 26 | 617 26 | 469 26 | 556 23 | 780 41 | 780 41 | 662 36 | 715 35 | 587 32 | 662 30 | 662 30 | 662 30 | 662 30 | 662 30 | 814 45 | 810 45 |
| 14.0 | 693 37 | 727 36 | 530 29 | 659 29 | 530 29 | 606 25 | 833 47 | 833 47 | 761 40 | 765 39 | 666 36 | 712 34 | 666 36 | 666 36 | 666 36 | 666 36 | 666 36 | 666 36 |
| 15.5 | 772 41 | 772 40 | 587 32 | 696 33 | 587 32 | 643 28 | --- | --- | 810 44 | 810 44 | 742 39 | 753 39 | 742 39 | 742 39 | 742 39 | 742 39 | 742 39 | 742 39 |
| | | | | | | | | | | | | | | | | | | |

CAUTION: Changing to Low Pressure mode will typically increase nozzle reaction.

(1) Number on top in each box indicates flow (LPM), and number on bottom indicates nozzle reaction (KG). (2) In Standard mode, the average nozzle pressure is 7 bar. (3) Flows may vary with brand or condition of hose. (4) Flows are approximate and do not reflect losses in preconnect piping.

For Nozzles with: Serial # TFT-H465101 and over or Manufactured after 12/01/2003

DualForce 100/55 PSI

Flow And Nozzle Reaction Chart

STD = STANDARD PRESSURE MODE
LP = LOW PRESSURE MODE

| FLOW (GPM) REACTION (LBS) | 1 1/2" HOSE | | | | | | 1 3/4" HOSE | | | | | | 2" HOSE | | | | | | 2 1/2" HOSE | | | | | |
|------------------------------------|-------------|-----|---------|-----|---------|-----|-------------|-----|---------|-----|---------|-----|---------|-----|---------|-----|---------|-----|-------------|-----|---------|-----|---------|-----|
| | 150 ft. | | 200 ft. | | 250 ft. | | 150 ft. | | 200 ft. | | 250 ft. | | 150 ft. | | 200 ft. | | 250 ft. | | 150 ft. | | 200 ft. | | 250 ft. | |
| | STD | LP | STD | LP | STD | LP | STD | LP | STD | LP | STD | LP | STD | LP | STD | LP | STD | LP | STD | LP | STD | LP | STD | LP |
| 50 | 48 | 54 | 47 | 50 | 45 | 47 | 50 | 62 | 49 | 56 | 48 | 53 | 51 | 76 | 51 | 70 | 50 | 65 | 53 | 107 | 53 | 102 | 53 | 97 |
| | 16 | 17 | 15 | 15 | 14 | 14 | 17 | 20 | 16 | 18 | 15 | 17 | 18 | 25 | 17 | 23 | 17 | 21 | 19 | 37 | 19 | 35 | 19 | 33 |
| 75 | 59 | 91 | 57 | 80 | 56 | 72 | 61 | 110 | 60 | 98 | 59 | 89 | 63 | 141 | 62 | 127 | 61 | 116 | 65 | 206 | 65 | 194 | 65 | 184 |
| | 23 | 31 | 22 | 27 | 21 | 24 | 25 | 38 | 24 | 33 | 23 | 30 | 27 | 51 | 26 | 45 | 25 | 40 | 28 | 82 | 28 | 76 | 28 | 71 |
| 100 | 74 | 118 | 69 | 104 | 65 | 94 | 83 | 144 | 77 | 128 | 73 | 116 | 99 | 185 | 91 | 166 | 86 | 152 | 135 | 265 | 128 | 254 | 122 | 242 |
| | 33 | 41 | 30 | 36 | 28 | 32 | 38 | 52 | 35 | 45 | 33 | 40 | 47 | 71 | 43 | 62 | 40 | 56 | 66 | 119 | 62 | 110 | 59 | 103 |
| 125 | 100 | 141 | 89 | 124 | 82 | 112 | 119 | 172 | 107 | 152 | 98 | 138 | 152 | 221 | 136 | 199 | 126 | 182 | 245 | 299 | 223 | 288 | 207 | 279 |
| | 47 | 51 | 42 | 44 | 38 | 39 | 58 | 65 | 51 | 56 | 46 | 50 | 76 | 90 | 67 | 78 | 61 | 70 | 128 | 149 | 115 | 139 | 106 | 130 |
| 150 | 124 | 160 | 110 | 141 | 100 | 128 | 151 | 196 | 134 | 174 | 122 | 157 | 198 | 252 | 176 | 227 | 160 | 208 | 328 | 326 | 312 | 315 | 283 | 306 |
| | 60 | 60 | 53 | 51 | 47 | 45 | 75 | 77 | 66 | 66 | 59 | 58 | 101 | 108 | 89 | 93 | 80 | 80 | 179 | 179 | 166 | 167 | 149 | 156 |
| 175 | 146 | 178 | 128 | 157 | 116 | 142 | 179 | 217 | 158 | 193 | 143 | 175 | 238 | 274 | 210 | 251 | 190 | 230 | --- | --- | 340 | 340 | 331 | 329 |
| | 72 | 68 | 63 | 58 | 56 | 51 | 91 | 88 | 79 | 75 | 71 | 66 | 124 | 126 | 108 | 108 | 97 | 95 | --- | --- | 195 | 195 | 183 | 182 |
| 200 | 165 | 194 | 145 | 171 | 131 | 154 | 204 | 237 | 179 | 210 | 162 | 190 | 273 | 294 | 240 | 270 | 217 | 250 | --- | --- | --- | --- | --- | --- |
| | 83 | 76 | 72 | 64 | 64 | 57 | 105 | 99 | 91 | 84 | 81 | 74 | 144 | 144 | 125 | 123 | 112 | 108 | --- | --- | --- | --- | --- | --- |
| 225 | 183 | 209 | 160 | 184 | 144 | 166 | 227 | 255 | 199 | 226 | 179 | 205 | 307 | 311 | 268 | 287 | 242 | 268 | --- | --- | --- | --- | --- | --- |
| | 93 | 84 | 80 | 71 | 71 | 62 | 117 | 110 | 101 | 93 | 91 | 81 | 163 | 163 | 141 | 138 | 126 | 121 | --- | --- | --- | --- | --- | --- |
| 250 | 199 | 223 | 174 | 196 | 157 | 177 | 248 | 269 | 216 | 241 | 195 | 218 | 329 | 328 | 293 | 303 | 264 | 283 | --- | --- | --- | --- | --- | --- |
| | 102 | 91 | 88 | 77 | 81 | 67 | 129 | 122 | 112 | 102 | 100 | 89 | 181 | 181 | 155 | 154 | 139 | 134 | --- | --- | --- | --- | --- | --- |

CAUTION: Changing to Low Pressure mode will typically increase nozzle reaction.

(1) Number on top of each box indicates flow (GPM), and number on bottom indicates nozzle reaction (LBS). (2) In Standard mode, the average nozzle pressure is 100 PSI. (3) Flows may vary with brand or condition of hose. (4) Flows are approximate and do not reflect losses in preconnect piping.

For Nozzles with: Serial # TFT-H465101 and over or Manufactured after 12/01/2003

DualForce 7/4 BAR

Flow And Nozzle Reaction Chart

7 bar = STANDARD PRESSURE MODE

LP = LOW PRESSURE MODE

| FLOW (l/min) REACTION (KG) | 38mm HOSE | | | | | | 45mm HOSE | | | | | | 50mm HOSE | | | | | | 64mm HOSE | | | | | |
|-------------------------------------|-----------|-----|-------|-----|-------|-----|-----------|-----|-------|-----|-------|------|-----------|------|-------|------|-------|------|-----------|------|-------|------|-------|-----|
| | 45M | | 60M | | 75M | | 45M | | 60M | | 75M | | 45M | | 60M | | 75M | | 45M | | 60M | | 75M | |
| | 7 bar | LP | 7 bar | LP | 7 bar | LP | 7 bar | LP | 7 bar | LP | 7 bar | LP | 7 bar | LP | 7 bar | LP | 7 bar | LP | 7 bar | LP | 7 bar | LP | 7 bar | LP |
| 3.5 | 182 | 204 | 178 | 189 | 170 | 178 | 185 | 212 | 182 | 201 | 193 | 288 | 193 | 265 | 189 | 246 | 201 | 405 | 201 | 386 | 201 | 367 | 15 | 15 |
| 5.2 | 223 | 344 | 212 | 303 | 212 | 273 | 227 | 371 | 223 | 337 | 238 | 534 | 235 | 481 | 231 | 439 | 246 | 780 | 246 | 734 | 246 | 696 | 32 | 32 |
| 7.0 | 280 | 447 | 246 | 394 | 246 | 356 | 291 | 484 | 276 | 439 | 375 | 700 | 344 | 628 | 326 | 575 | 511 | 1003 | 484 | 961 | 462 | 916 | 47 | 47 |
| 8.6 | 379 | 534 | 310 | 469 | 310 | 424 | 405 | 575 | 371 | 522 | 575 | 836 | 515 | 753 | 477 | 689 | 927 | 1132 | 844 | 1090 | 783 | 1056 | 59 | 59 |
| 10.0 | 469 | 606 | 379 | 534 | 379 | 484 | 507 | 659 | 462 | 594 | 749 | 954 | 666 | 859 | 606 | 787 | 1241 | 1234 | 1181 | 1192 | 1071 | 1158 | 71 | 71 |
| 12.0 | 553 | 674 | 439 | 594 | 439 | 537 | 598 | 731 | 541 | 662 | 901 | 1037 | 795 | 950 | 719 | 871 | 6 | 6 | 1287 | 1287 | 1253 | 1245 | 83 | 83 |
| 14.0 | 625 | 734 | 496 | 647 | 496 | 583 | 678 | 795 | 613 | 719 | 1033 | 1113 | 908 | 1022 | 821 | 946 | 6 | 6 | --- | 6 | 6 | 6 | 6 | 6 |
| 15.5 | 693 | 791 | 545 | 696 | 545 | 628 | 753 | 855 | 678 | 776 | 1162 | 1177 | 1014 | 1086 | 916 | 1014 | 6 | 6 | 6 | 6 | 6 | 6 | 6 | 6 |
| 17.0 | 753 | 844 | 594 | 742 | 594 | 670 | 818 | 912 | 738 | 825 | 1245 | 1241 | 1109 | 1147 | 999 | 1071 | 6 | 6 | --- | 6 | 6 | --- | --- | --- |

CAUTION: Changing to Low Pressure mode will typically increase nozzle reaction.

(1) Number on top of each box indicates flow (GPM), and number on bottom indicates nozzle reaction (LBS). (2) In Standard mode, the average nozzle pressure is 100 PSI. (3) Flows may vary with brand or condition of hose. (4) Flows are approximate and do not reflect losses in preconnect piping.

For Nozzles with: Serial # TFT-H465101 and over or Manufactured after 12/01/2003

DualForce 75/45 PSI

Flow And Nozzle Reaction Chart

STD = STANDARD PRESSURE MODE
LP = LOW PRESSURE MODE

| FLOW (GPM) REACTION (LBS) | 1 1/2" HOSE | | | | | | 1 3/4" HOSE | | | | | | 2" HOSE | | | | | | 2 1/2" HOSE | | | | | |
|------------------------------------|-------------|-----|---------|-----|---------|-----|-------------|-----|---------|-----|---------|-----|---------|-----|---------|-----|---------|-----|-------------|-----|---------|-----|---------|-----|
| | 150 ft. | | 200 ft. | | 250 ft. | | 150 ft. | | 200 ft. | | 250 ft. | | 150 ft. | | 200 ft. | | 250 ft. | | 150 ft. | | 200 ft. | | 250 ft. | |
| | STD | LP | STD | LP | STD | LP | STD | LP | STD | LP | STD | LP | STD | LP | STD | LP | STD | LP | STD | LP | STD | LP | STD | LP |
| 50 | 48 | 71 | 47 | 65 | 45 | 60 | 84 | 49 | 75 | 48 | 70 | 51 | 107 | 51 | 96 | 88 | 50 | 88 | 53 | 157 | 53 | 148 | 53 | 140 |
| | 16 | 20 | 15 | 18 | 14 | 16 | 25 | 16 | 22 | 15 | 20 | 18 | 33 | 17 | 29 | 26 | 17 | 26 | 19 | 52 | 19 | 48 | 18 | 45 |
| 75 | 64 | 104 | 60 | 91 | 58 | 82 | 126 | 67 | 112 | 63 | 101 | 88 | 162 | 81 | 145 | 133 | 76 | 133 | 123 | 230 | 116 | 221 | 111 | 212 |
| | 25 | 31 | 23 | 27 | 22 | 24 | 39 | 26 | 34 | 25 | 30 | 36 | 54 | 33 | 47 | 42 | 31 | 42 | 52 | 89 | 49 | 83 | 46 | 77 |
| 100 | 96 | 130 | 85 | 114 | 77 | 103 | 115 | 103 | 139 | 93 | 126 | 148 | 203 | 132 | 182 | 166 | 121 | 166 | 252 | 269 | 224 | 260 | 206 | 251 |
| | 39 | 41 | 34 | 35 | 31 | 31 | 48 | 42 | 44 | 38 | 39 | 64 | 72 | 57 | 63 | 56 | 51 | 56 | 114 | 120 | 101 | 112 | 92 | 105 |
| 125 | 122 | 151 | 108 | 133 | 98 | 120 | 149 | 131 | 162 | 119 | 147 | 197 | 232 | 173 | 212 | 194 | 158 | 194 | 300 | 300 | 290 | 290 | 282 | 281 |
| | 52 | 49 | 45 | 42 | 40 | 37 | 64 | 56 | 54 | 50 | 48 | 88 | 90 | 76 | 77 | 69 | 69 | 68 | 150 | 150 | 140 | 140 | 131 | 131 |
| 150 | 145 | 170 | 124 | 149 | 115 | 135 | 177 | 156 | 182 | 141 | 165 | 239 | 256 | 210 | 234 | 218 | 189 | 218 | 343 | 341 | 317 | 335 | 307 | 307 |
| | 63 | 57 | 54 | 48 | 48 | 43 | 78 | 68 | 63 | 61 | 55 | 108 | 108 | 94 | 92 | 84 | 84 | 81 | 185 | 185 | 167 | 173 | 157 | 157 |
| 175 | 165 | 187 | 144 | 164 | 130 | 148 | 203 | 178 | 201 | 160 | 182 | 276 | 276 | 242 | 255 | 236 | 217 | 236 | 356 | 355 | 349 | 348 | 342 | 342 |
| | 72 | 65 | 62 | 55 | 56 | 48 | 91 | 79 | 71 | 70 | 63 | 127 | 127 | 109 | 108 | 98 | 94 | 94 | 210 | 209 | 198 | 197 | 186 | 186 |
| 200 | 183 | 202 | 160 | 178 | 144 | 160 | 227 | 198 | 217 | 178 | 197 | 295 | 295 | 270 | 272 | 243 | 243 | 254 | 369 | 368 | 362 | 361 | 356 | 354 |
| | 81 | 72 | 70 | 61 | 62 | 53 | 102 | 88 | 80 | 79 | 70 | 145 | 145 | 123 | 123 | 110 | 107 | 107 | 235 | 234 | 222 | 221 | 210 | 209 |
| 225 | 200 | 216 | 174 | 190 | 157 | 172 | 249 | 216 | 231 | 195 | 211 | 312 | 313 | 289 | 288 | 266 | 269 | 269 | 6 | 6 | 375 | 373 | 368 | 367 |
| | 89 | 80 | 77 | 66 | 68 | 58 | 113 | 97 | 90 | 87 | 77 | 163 | 163 | 138 | 138 | 121 | 120 | 120 | 6 | 6 | 245 | 245 | 232 | 232 |
| 250 | 216 | 229 | 188 | 202 | 169 | 182 | 269 | 234 | 244 | 210 | 223 | 329 | 336 | 304 | 304 | 284 | 284 | 284 | --- | --- | 6 | 6 | 380 | 378 |
| | 97 | 88 | 83 | 72 | 74 | 63 | 123 | 106 | 99 | 94 | 85 | 181 | 180 | 154 | 154 | 133 | 134 | 134 | --- | --- | --- | --- | 255 | 255 |

CAUTION: Changing to Low Pressure mode will typically increase nozzle reaction.

(1) Number on top of each box indicates flow (GPM), and number on bottom indicates nozzle reaction (LBS). (2) In Standard mode, the average nozzle pressure is 100 PSI. (3) Flows may vary with brand or condition of hose. (4) Flows are approximate and do not reflect losses in preconnect piping.

For Nozzles with: Serial # TFT-H465101 and over or Manufactured after 12/01/2003

Dual-Force 5/3 BAR

Flow And Nozzle Reaction Chart

7 bar = STANDARD PRESSURE MODE

LP = LOW PRESSURE MODE

| FLOW (l/min) REACTION (KG) | 38mm HOSE | | | | | | 45mm HOSE | | | | | | 50mm HOSE | | | | | | 64mm HOSE | | | | | | | | | | |
|-------------------------------------|-----------|-----|-------|-----|-------|-----|-----------|------|-------|-----|-------|------|-----------|------|-------|------|-------|------|-----------|------|-------|------|-------|------|-------|------|-------|------|------|
| | 60M | | 75M | | 75M | | 60M | | 75M | | 75M | | 60M | | 75M | | 45M | | 60M | | 75M | | 45M | | 60M | | 75M | | |
| | 5 bar | LP | 5 bar | LP | 5 bar | LP | 5 bar | LP | 5 bar | LP | 5 bar | LP | 5 bar | LP | 5 bar | LP | 7 bar | LP | 5 bar | LP | 5 bar | LP | 7 bar | LP | 5 bar | LP | 5 bar | LP | |
| 3.5 | 182 | 269 | 178 | 246 | 170 | 227 | 189 | 318 | 185 | 284 | 265 | 193 | 405 | 193 | 363 | 189 | 333 | 201 | 594 | 201 | 560 | 201 | 201 | 594 | 201 | 560 | 201 | 530 | 201 |
| | 7 | 8 | 7 | 8 | 6 | 7 | 8 | 11 | 7 | 10 | 9 | 8 | 15 | 8 | 13 | 8 | 12 | 9 | 24 | 9 | 22 | 9 | 24 | 9 | 22 | 8 | 20 | 8 | 20 |
| 5.2 | 242 | 394 | 227 | 344 | 220 | 310 | 276 | 477 | 254 | 424 | 382 | 333 | 613 | 307 | 549 | 288 | 503 | 466 | 871 | 439 | 836 | 439 | 466 | 871 | 439 | 836 | 420 | 802 | 420 |
| | 11 | 14 | 10 | 12 | 10 | 11 | 13 | 18 | 12 | 15 | 14 | 16 | 24 | 15 | 21 | 14 | 19 | 24 | 40 | 22 | 38 | 22 | 40 | 22 | 38 | 21 | 35 | 21 | 35 |
| 7.0 | 363 | 492 | 322 | 431 | 291 | 390 | 435 | 594 | 390 | 526 | 477 | 560 | 768 | 500 | 689 | 458 | 628 | 954 | 1018 | 848 | 984 | 1018 | 954 | 1018 | 848 | 984 | 780 | 950 | 780 |
| | 18 | 19 | 15 | 16 | 14 | 14 | 22 | 24 | 19 | 20 | 18 | 29 | 33 | 26 | 29 | 23 | 25 | 52 | 54 | 46 | 51 | 46 | 52 | 54 | 46 | 51 | 42 | 48 | 48 |
| 8.6 | 462 | 572 | 409 | 503 | 371 | 454 | 564 | 693 | 496 | 613 | 556 | 746 | 878 | 655 | 802 | 598 | 734 | 1136 | 1136 | 1098 | 1098 | 1098 | 1136 | 1098 | 1098 | 1067 | 1064 | 1064 | 1064 |
| | 24 | 23 | 20 | 19 | 18 | 17 | 29 | 29 | 25 | 24 | 23 | 40 | 41 | 34 | 35 | 31 | 31 | 68 | 68 | 64 | 64 | 64 | 68 | 64 | 64 | 59 | 59 | 59 | 59 |
| 10.0 | 549 | 643 | 481 | 564 | 435 | 511 | 670 | 780 | 590 | 689 | 625 | 905 | 969 | 795 | 886 | 715 | 825 | 1298 | 1291 | 1200 | 1268 | 1268 | 1298 | 1200 | 1268 | 1162 | 1162 | 1162 | 1162 |
| | 29 | 27 | 24 | 22 | 22 | 20 | 35 | 34 | 31 | 29 | 28 | 49 | 49 | 43 | 42 | 38 | 37 | 84 | 84 | 76 | 78 | 76 | 84 | 76 | 78 | 71 | 71 | 71 | 71 |
| 12.0 | 625 | 708 | 545 | 621 | 492 | 560 | 768 | 852 | 674 | 761 | 689 | 1045 | 1045 | 916 | 965 | 821 | 893 | 1347 | 1344 | 1321 | 1317 | 1317 | 1347 | 1321 | 1317 | 1298 | 1294 | 1294 | 1294 |
| | 33 | 31 | 28 | 25 | 25 | 22 | 41 | 39 | 36 | 32 | 29 | 58 | 58 | 49 | 49 | 44 | 43 | 95 | 95 | 90 | 89 | 90 | 95 | 90 | 89 | 84 | 84 | 84 | 84 |
| 14.0 | 693 | 765 | 606 | 674 | 545 | 606 | 859 | 912 | 749 | 821 | 746 | 1117 | 1117 | 1022 | 1030 | 920 | 961 | 1397 | 1393 | 1370 | 1366 | 1366 | 1397 | 1370 | 1366 | 1347 | 1340 | 1340 | 1340 |
| | 37 | 34 | 32 | 28 | 28 | 24 | 46 | 44 | 40 | 36 | 32 | 66 | 66 | 56 | 56 | 50 | 49 | 107 | 106 | 101 | 100 | 100 | 107 | 101 | 100 | 95 | 95 | 95 | 95 |
| 15.5 | 757 | 818 | 659 | 719 | 594 | 651 | 942 | 973 | 818 | 874 | 799 | 1181 | 1185 | 1094 | 1090 | 1007 | 1018 | 1419 | 1419 | 1412 | 1412 | 1412 | 1419 | 1412 | 1412 | 1393 | 1389 | 1389 | 1389 |
| | 40 | 38 | 35 | 30 | 31 | 26 | 51 | 49 | 44 | 41 | 39 | 74 | 74 | 63 | 63 | 55 | 54 | 111 | 111 | 111 | 111 | 111 | 111 | 111 | 111 | 105 | 105 | 105 | 105 |
| 17.0 | 818 | 867 | 712 | 765 | 640 | 689 | 1018 | 1026 | 886 | 924 | 844 | 1245 | 1272 | 1151 | 1151 | 1075 | 1075 | 1438 | 1438 | 1431 | 1431 | 1431 | 1438 | 1431 | 1431 | 1431 | 1431 | 1431 | 1431 |
| | 44 | 41 | 38 | 33 | 34 | 29 | 56 | 55 | 48 | 45 | 39 | 82 | 82 | 70 | 70 | 60 | 61 | 116 | 116 | 116 | 116 | 116 | 116 | 116 | 116 | 116 | 116 | 116 | 116 |

CAUTION: Changing to Low Pressure mode will typically increase nozzle reaction.

(1) Number on top of each box indicates flow (GPM), and number on bottom indicates nozzle reaction (LBS). (2) In Standard mode, the average nozzle pressure is 100 PSI. (3) Flows may vary with brand or condition of hose. (4) Flows are approximate and do not reflect losses in preconnect piping.

4.3 REACH AND TRAJECTORY

Care must be taken to avoid dents or nicks in the nozzle tip because they can seriously affect the stream reach.

The following are specific examples of maximum flow rates for particular situations. Friction losses may vary due to differences in hose construction resulting in flows different than those shown. For situations or lengths of hose not listed on the chart, approximate flows can be calculated using conventional hydraulics.

All reach testing was taken in still air conditions at an elevation of 30 degrees.

MID-FORCE

Flow range 70-200 GPM, automatic pressure control at emergency low pressure mode.

NOZZLE TESTED

Mid-Force
Model: HM-VPGI
Serial #: TFTH-145249

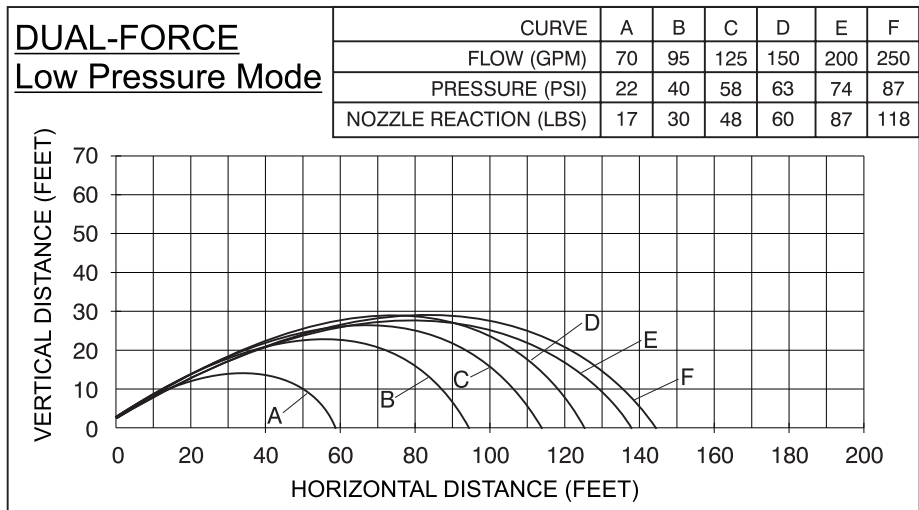
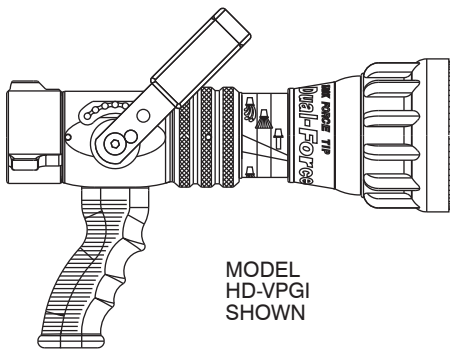
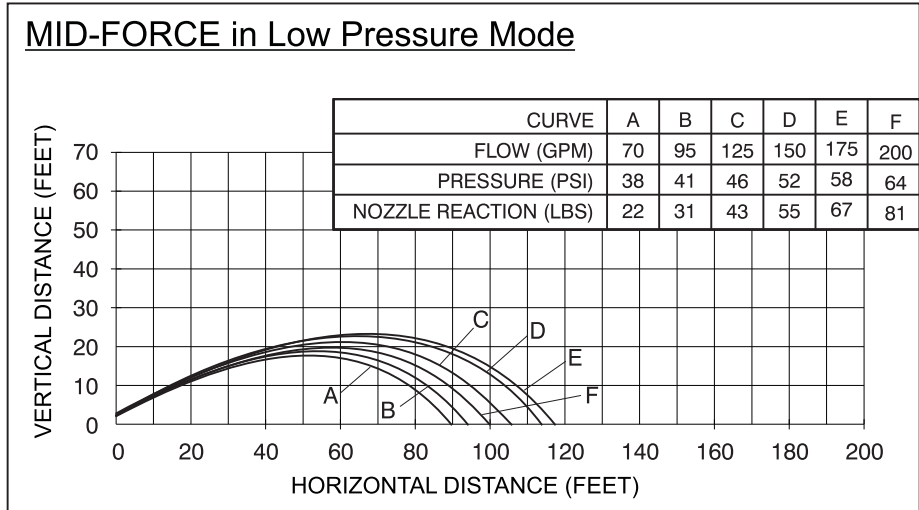

DUAL-FORCE

Flow range 70-250 GPM, automatic pressure control with 100 PSI and emergency low pressure mode.

NOZZLE TESTED

DUAL-FORCE
Model: HD-VPGI
Serial #: TFTH-041501

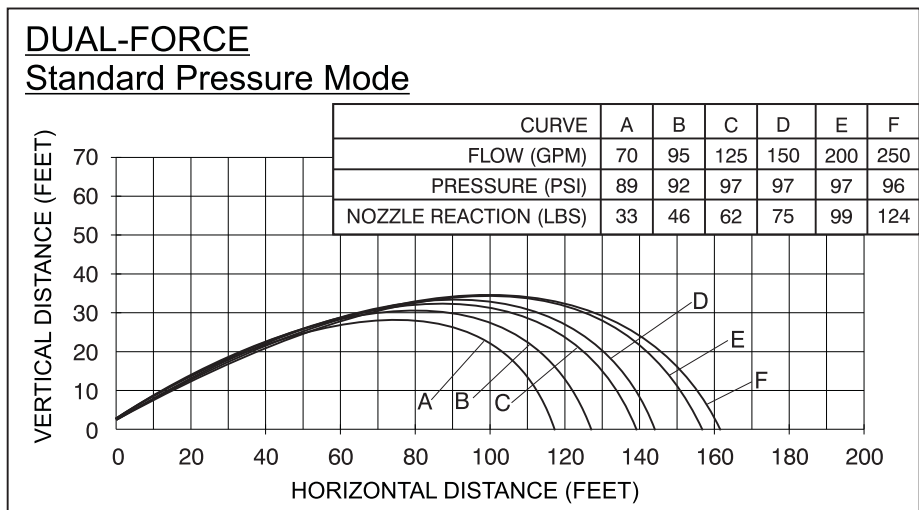

5.0 NOZZLE CONTROLS

Nozzle control valves must be opened slowly to eliminate unnecessary strain on the hose and couplings and reduce pressure surges.

5.1 FLOW CONTROL

5.1.1 LEVER TYPE FLOW CONTROL

On models that use a lever type valve handle, the nozzle is shut off when the handle is fully forward. The valve handle has detented flow positions. These detent positions allow the nozzle operator to regulate the flow of the nozzle depending on the need or what can be safely and effectively handled. TFT recommends the use of a pistol grip for easier handling. For additional stress reduction, a hose rope or strap may also be used. This permits more effective use and ease of advancement, while minimizing strain and fatigue.

Nozzles attached to an in-service hose shall be stored in the off position.

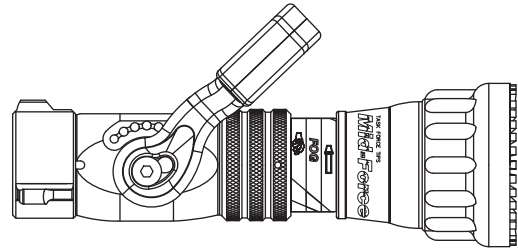

5.1.2 TIP ONLY

Tip only nozzles have NO shut-off valve within the nozzle and MUST be used with a separate ball valve attached to the nozzle. Using a nozzle without a shutoff is an unsafe practice and should never be done.

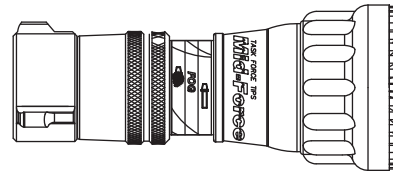

5.1.3 BALL SHUT-OFF

A separate ball valve for use with Tip Only nozzles is shut off when the valve handle is fully forward. Pulling back on the handle opens the valve. Open valve slowly to avoid sudden changes in nozzle reaction. Close valve slowly to prevent water hammer. Note: In partially open positions a ball valve will cause turbulence and adversely affect stream quality. Nozzles attached to an in-service hose shall be stored in the off position.

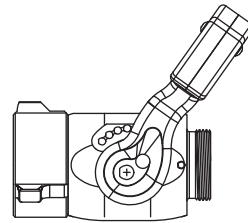

5.1.4 TWIST SHUT-OFF

On models that use a twist flow control, the valve is opened or closed by rotating the valve ring. Rotating the ring clockwise (as seen from the operating position behind the nozzle) closes the valve, while counterclockwise rotation opens it. Detents are provided at four intermediate positions and the position of the valve is shown by the exposed valve position label. Nozzles attached to an in-service hose shall be stored in the off position.

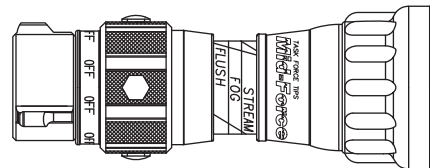

5.1.5 IMPULSE TRIGGER FLOW CONTROL

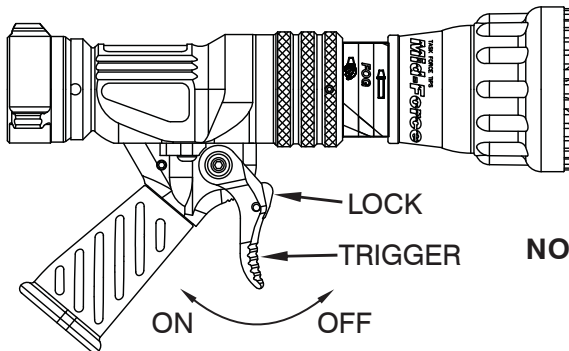

NOTE: THE TRIGGER RETURNS TO OFF IF NOT HELD OR LOCKED



Do not intentionally release the nozzle while flowing and trust the valve to shut off automatically. The trigger nozzle's ability to shut off by itself represents an extra level of safety when following normal nozzle handling procedures. To rely on it as the sole means of safety increases the risk of injury from an out of control nozzle. Release nozzle when flow has stopped.

5.1.5.1 IMPULSE TRIGGER LOCK

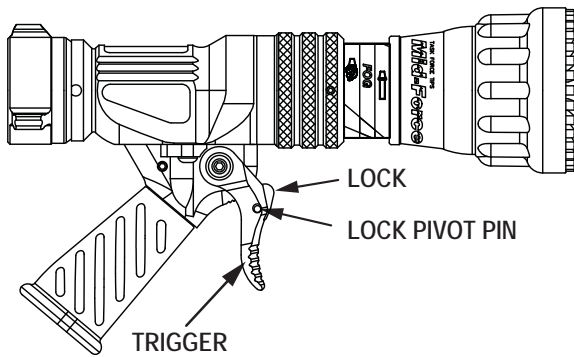

To Lock: Push on the lock while pulling back the trigger to engage one of the four locked positions.

To Release: Pull back slightly on trigger without any pressure on the lock. The spring loaded lock will automatically move to the unlocked position.

Use an 1/8" (3mm) punch to push out pin and remove lock if the lock is not desired.

▲WARNING

When the trigger lock is engaged, the nozzle will not shut off if dropped. Always shut off nozzle before releasing the pistol grip to avoid injury from an out of control nozzle.

5.1.5.2 TRIGGER FLOW CONTROL SPEED ADJUSTMENT

The IMPULSE valve contains a slow close mechanism to prevent the nozzle from slamming off if the trigger is suddenly released. The closing speed is set at the factory to be slow enough to reduce water hammer, ("water hammer" is always present in any valve when it is shut off. The slow close mechanism will reduce this but cannot eliminate it completely) but fast enough to reduce the potential danger of hose whipping from a dropped nozzle. The closing speed may be adjusted as shown in the figure.5.1.5.2.

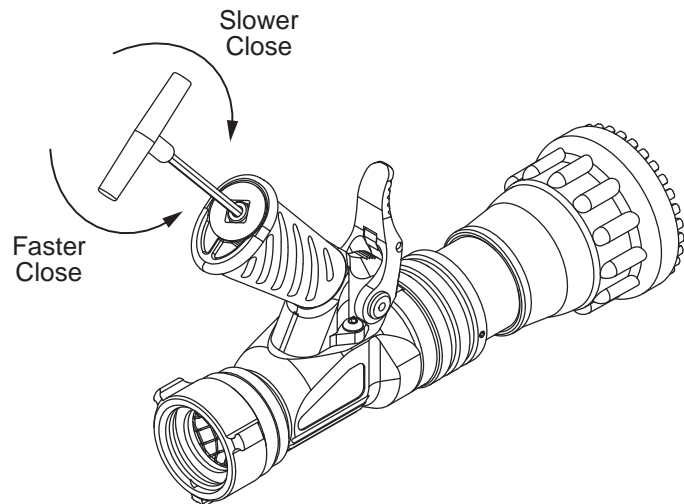

Do not unscrew the adjuster past the end of the hand grip (to unscrew it too far could result in the loss of dampening fluid.)

▲WARNING

As the closing time is increased so does the risk of injury from an out of control nozzle. A flowing nozzle can cause injury within the first second of lost control. Use caution when adjusting the closing speed and always verify performance after adjustment.

5.1.5.3 NORMAL OPERATING POSITION

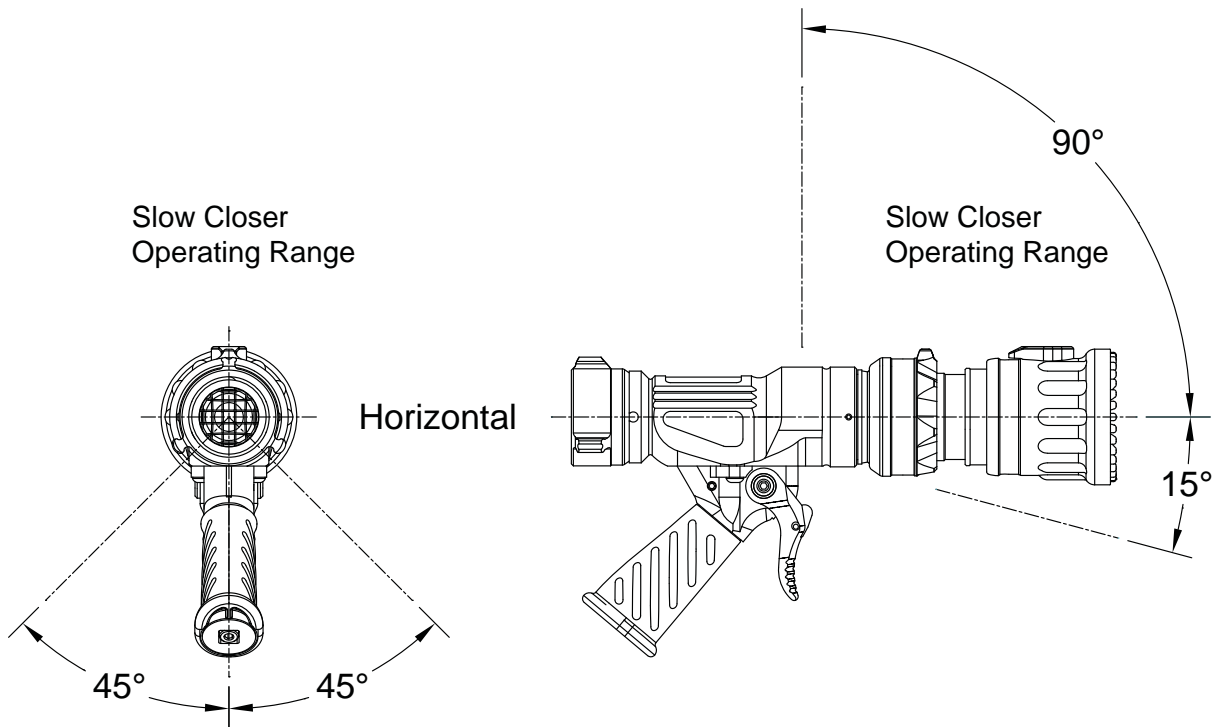

⚠ WARNING

The Slow Close Feature relies on a fluid and air combination in the pistol grip. For proper function, the pistol grip should be within its normal operating position. The normal operating position is with the nozzle horizontal or pointing up with the pistol grip within 45 degrees of vertical. Releasing the trigger suddenly outside of the normal orientation will likely result in faster shut-off causing a higher pressure spike and increasing the risk of a burst hose. Do not suddenly release the trigger when operating outside of the nozzle's normal orientation.

5.2 PATTERN AND FLUSH CONTROL

5.2.1 PATTERN CONTROL

TFT's nozzles have full pattern control from straight stream to wide fog. Turning the stream shaper clockwise (as seen from the operating position behind the nozzle) moves the shaper to the straight stream position. Turning the shaper counterclockwise will result in an increasingly wider pattern.

Since the stream trim point varies with flow, the stream should be "trimmed" after changing the flow to obtain the straightest and farthest reaching stream. To properly trim the stream, first open the pattern to narrow fog. Then close the stream to parallel to give maximum reach. **Note: Turning the shaper further forward will cause stream crossover and reduce the effective reach of the nozzle.**

The nozzle reaction is greatest when the shaper is in the straight stream position. The nozzle operator must be prepared for a change in reaction as the pattern is changed.

5.2.2 FLUSH CONTROL

Small debris passes through the debris screen (if equipped) and may get caught inside the nozzle. This trapped material will cause poor stream quality, shortened reach, and reduced flow. To remove small debris, the nozzle may be flushed as follows:

- While still flowing water, rotate the SHAPER counterclockwise (as viewed from behind the nozzle) to the flush position. (increased resistance will be felt on the SHAPER or RING as the nozzle goes into flush) This will open the nozzle allowing debris to pass through.
- During flush the nozzle reaction will decrease as the pattern becomes wider and the pressure drops. The nozzle operator must be prepared for an increase of nozzle reaction when returning the nozzle from the flush position to retain control of the nozzle.
- Rotate the SHAPER out of flush to continue normal operations.

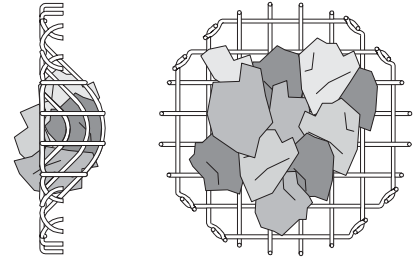

WARNING Large amounts or pieces of debris may be unflushable and can reduce the flow of the nozzle resulting in an ineffective flow. In the event of a blockage, it may be necessary to retreat to a safe area, uncouple the nozzle and remove debris.

5.3 STANDARD/LOW PRESSURE KNOB MID-FORCE & DUAL-FORCE

For situations where the standard pressure setting at the nozzle is impractical, the MID-FORCE or DUAL-FORCE may be switched to a low pressure mode. In the low pressure mode the nozzle pressure is reduced by about 50% while maintaining a usable stream and increasing the flow. The nozzle operator must be prepared for a change in reaction when changing modes. See the flow chart in section 4.2 for actual performance.

To switch to the low pressure mode, shut off water flow with valve and turn knob at front of nozzle (see figure 4) counterclockwise (when viewed from front). Reopen valve to flow water at reduced pressure. Repeat the process, except turn knob clockwise, to return to standard pressure operation

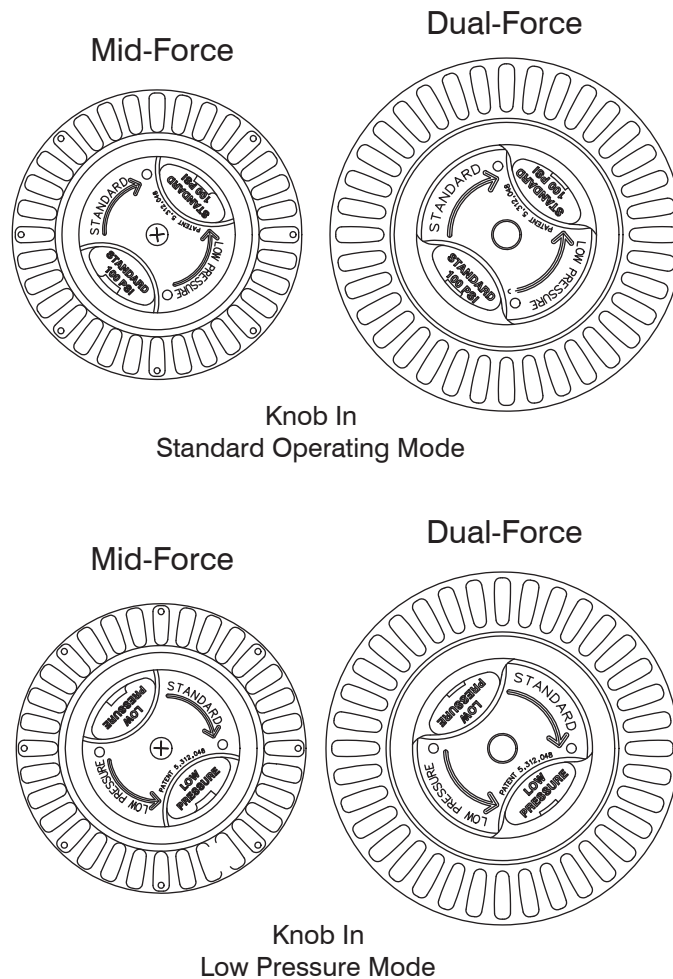

6.0 USE WITH FOAM

The nozzle may be used with foam solutions. Refer to fire service training for the proper use of foam.

⚠ WARNING

For Class B fires, lack of foam or interruption in the foam stream can cause a break in the foam blanket and greatly increase the risk of injury or death.

Assure that:

- Application rate is sufficient (see NFPA 11 or foam manufacturer's recommendations)
- Enough concentrate is on hand to complete task (see NFPA for minimum duration time requirements)
- Foam logistics have been carefully planned.

Allow for such things as:

- Storage of foam in a location not exposed to the hazard it protects
- Personnel, equipment and technique to deliver foam at a rapid enough rate
- Removal of empty foam containers
- Clear path to deliver foam, as hoses and other equipment and vehicles are deployed

⚠ WARNING

Improper use of foam can result in injury or damage to the environment. Follow foam manufacturer's instructions and fire service training to avoid:

- Using wrong type of foam on a fire, i.e. Class A foam on a Class B fire
- Plunging foam into pools of burning liquid fuels
- Causing environmental damage
- Directing stream at personnel

⚠ WARNING

There are a wide variety of foam concentrates. Each user is responsible for verifying that any foam concentrate chosen to be used with this unit has been tested to assure that the foam obtained is suitable for the purpose intended.

⚠ WARNING

Use of compressed air foam (CAF) with hand held nozzles can cause sudden surges in nozzle reaction force resulting in risk of injury or death from loss of footing or hose whipping. Be prepared for sudden changes in nozzle reaction caused by:

- Slug loading (Loss of foam concentrate sends slugs of air and water into the nozzle)
- Sudden release of built-up pressure in the hose when opening a nozzle

6.1 FOAM ASPIRATING ATTACHMENTS

Multi-expansion or low expansion aspirating attachments may be used with nozzles to increase the expansion ratio. These foam tubes attach and detach quickly from the nozzle. As expansion ratio is increased, the reach of the nozzle will be decreased due to the greater amount of bubbles in the stream and their ability to penetrate the air. Generally the straight stream reach with foam is approximately 10% less than with water only. Actual results will vary based on brand of foam, hardness of water, temperature, etc. For specific information, see LIA-025 (MANUAL: Foam Attachments for TFT Nozzles).

7.0 USE OF NOZZLES

7.1 MID-FORCE AND DUAL-FORCE NOZZLES

Many factors contribute to the extinguishment of a fire. Among the most important is delivering water at a flow rate sufficient to absorb heat faster than it is being generated. The flow rate depends largely on the pump discharge pressure and hose friction loss. It can be calculated using a hydraulic equation such as:

$$PDP = NP + FL + DL + EL$$

PDP = Pump discharge pressure in PSI

NP = Nozzle pressure in PSI

FL = Hose friction loss in PSI

DL = Device loss in PSI

EL = Elevation loss in PSI

This manual is not intended to act as a training guide for safe fireground tactics and operations. For additional information visit www/tft.com or contact customer service at 800-348-2686.

IT IS THE RESPONSIBILITY OF THE INDIVIDUAL FIRE DEPARTMENT OR AGENCY TO DETERMINE PHYSICAL CAPABILITIES AND SUITABILITY FOR AN INDIVIDUAL'S USE OF THIS EQUIPMENT.

7.2 CAFS-FORCE 1 AND CAFS-FORCE 2 NOZZLES

The CAFS-FORCE 1 and CAFS-FORCE 2 nozzles are optimized for use with compressed air foam systems, CAFS. They have a streamlined flow path with no gasket grabber. The CAFS-FORCE nozzles have two settings: Standard pressure/Water and Low Pressure/CAFS. The CAFS-FORCE tip can be removed to use the valve as a smoothbore. See Section 4.0 Flow Characteristics for CAFS-FORCE Nozzle flow characteristics.

Hose handling techniques with compressed air foam (CAF) differ considerably from liquid filled hoses as a result of the added energy stored by pressurized air. The authority having jurisdiction must establish safe CAF operational procedures and insure appropriate training.

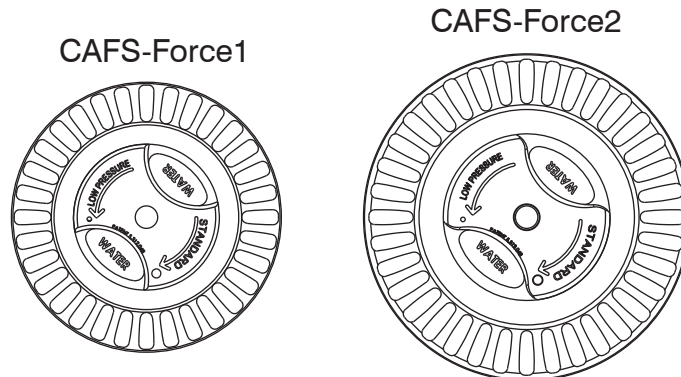

Knob In Standard Pressure Water Mode

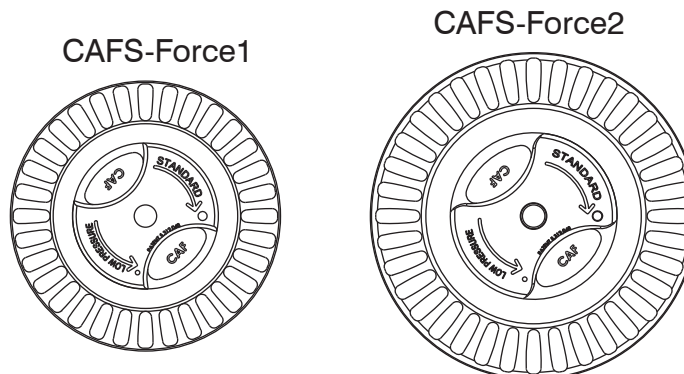

Knob In Low Pressure CAFS Mode

▲WARNING

Use of compressed air foam (CAF) with hand held nozzles can cause sudden surges in nozzle reaction force resulting in risk of injury or death from loss of footing or hose whipping. Be prepared for sudden changes in nozzle reaction caused by:
Slug loading (Loss of foam concentrate sends slugs of air and water into the nozzle)
Sudden release of built-up pressure in the hose when opening a nozzle

8.0 APPROVALS

Many nozzle configurations carry the FM Approval rating, NFPA certification, or EN certification.

9.0 COLOR CODED VALVE HANDLE AND PISTOL GRIP

The TFT nozzle with lever type valve handles are supplied with black valve handle covers and pistol grips. The handle covers and pistol grips are available from TFT in various colors for those departments wishing to color code the nozzle to the discharge controls. A colored handle cover set will be sent upon receipt of the warranty card by TFT. Your department's name can also be engraved on the covers (see warranty card for more information).

Handle covers are replaceable by removing the four screws that hold the handle covers in place. Use a 3/32" Allen wrench when replacing screws. Pistol grip is replaceable by following TFT instruction sheet LTT-108 for standard grips or LTT-115 for Trigger Controlled Valves.

For standardization NFPA 1901 (A-4-9.3) recommends the following color code scheme:

| | | |
|-----------------------------------|---------------------------------|-------------------------|
| Preconnect #1 or Bumper Jump Line | Orange | Other Colors Available: |
| Preconnect or discharge #2 | Red | • Gray |
| Preconnect or discharge #3 | Yellow | • Pink |
| Preconnect or discharge #4 | White | • Purple |
| Preconnect or discharge #5 | Blue | • Tan |
| Preconnect or discharge #6 | Black | |
| Preconnect or discharge #7 | Green | |
| Foam Lines | Red w/ White border (Red/White) | |

9.1 IMPULSE TRIGGER VALVE SYSTEM NOZZLE COLORED PISTOL GRIPS

The TFT Impulse Trigger Valve System nozzles are supplied with black pistol grip covers. The pistol grip covers are available from TFT in various colors for those departments wishing to color code the nozzle to the discharge controls. Follow the steps below to change the pistol grip cover.

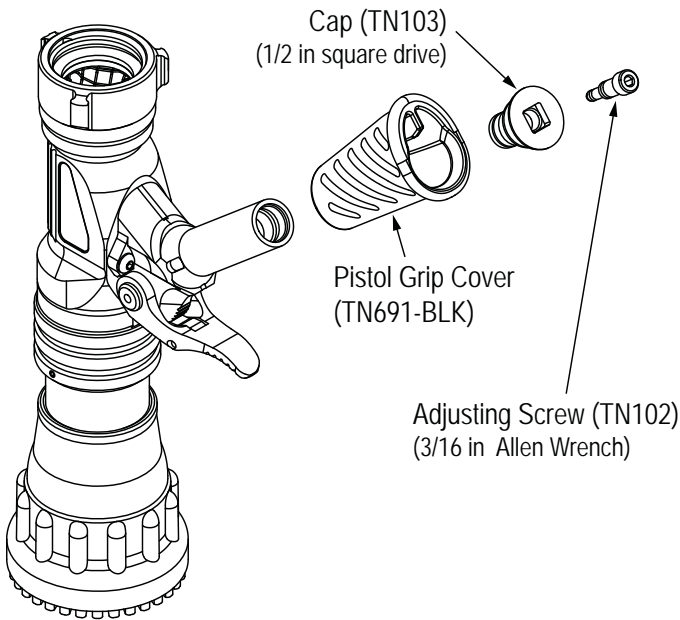

- 1) Orient nozzle vertically. This keeps the dampening fluid in the pistol grip from spilling out.
- 2) Remove the Cap. (1/2 in square drive) The Adjusting Screw (3/16 in Allen Wrench) may need to be turned in or removed to be able to engage the square pocket in the cap. Note the position of the Adjusting Screw before moving it.
- 3) Slide off the Pistol Grip Cover and install a new one. Be sure the Pistol Grip Cover's internal rib is toward the back of the nozzle.
- 4) Reinstall the Cap until it bottoms out on its shoulder.
- 5) Reinstall or reposition the Adjusting Screw if it has been moved from its original location.
- 6) Flow nozzle to check performance of slow closer. Adjust as needed (see section 5.1.5.2).

10.0 WARRANTY

Task Force Tips, Inc., 3701 Innovation Way, Valparaiso, Indiana 46383-9327 ("TFT") warrants to the original purchaser of its nozzles and other equipment ("equipment"), and to anyone to whom it is transferred, that the equipment shall be free from defects in material and workmanship during the five (5) year period from the date of purchase.

TFT's obligation under this warranty is specifically limited to replacing or repairing the equipment (or its parts) which are shown by TFT's examination to be in a defective condition attributable to TFT. To qualify for this limited warranty, the claimant must return the equipment to TFT, at 3701 Innovation Way, Valparaiso, Indiana 46383-9327, within a reasonable time after discovery of the defect. TFT will examine the equipment. If TFT determines that there is a defect attributable to it, TFT will correct the problem within a reasonable time. If the equipment is covered by this limited warranty, TFT will assume the expenses of repair.

If any defect attributable to TFT under this limited warranty cannot be reasonably cured by repair or replacement, TFT may elect to refund the purchase price of the equipment, less reasonable depreciation, in complete discharge of its obligations under this limited warranty. If TFT makes this election, claimant shall return the equipment to TFT free and clear of any liens and encumbrances.

This is a limited warranty. The original purchaser of the equipment, any person to whom it is transferred, and any person who is an intended or unintended beneficiary of the equipment, shall not be entitled to recover from TFT any consequential or incidental damages for injury to person and/or property resulting from any defective equipment manufactured or assembled by TFT. It is agreed and understood that the price stated for the equipment is in part consideration for limiting TFT's liability. Some states do not allow the exclusion or limitation of incidental or consequential damages, so the above may not apply to you.

TFT shall have no obligation under this limited warranty if the equipment is, or has been, misused or neglected (including failure to provide reasonable maintenance) or if there have been accidents to the equipment or if it has been repaired or altered by someone else.

THIS IS A LIMITED EXPRESS WARRANTY ONLY. TFT EXPRESSLY DISCLAIMS WITH RESPECT TO THE EQUIPMENT ALL IMPLIED WARRANTIES OF MERCHANTABILITY AND ALL IMPLIED WARRANTIES OF FITNESS FOR A PARTICULAR PURPOSE. THERE IS NO WARRANTY OF ANY NATURE MADE BY TFT BEYOND THAT STATED IN THIS DOCUMENT.

This limited warranty gives you specific legal rights, and you may also have other rights which vary from state to state

11.0 MAINTENANCE

TFT nozzles are designed and manufactured to be damage resistant and require minimal maintenance. However, as the primary firefighting tool upon which your life depends, it should be treated accordingly. Do not drop or throw equipment.

11.1 FIELD LUBRICATION

All Task Force Tip nozzles are factory lubricated with high quality silicone grease. This lubricant has excellent washout resistance and long term performance. If your department has unusually hard or sandy water, the moving parts may be affected. Foam agents and water additives contain soaps and chemicals that may break down the factory lubrication.

The moving parts of the nozzle should be checked on a regular basis for smooth and free operation, and signs of damage. IF THE NOZZLE IS OPERATING CORRECTLY, THEN NO ADDITIONAL LUBRICATION IS NEEDED. Any nozzle that is not operating correctly should be immediately removed from service.

The field use of Break Free CLP (spray or liquid) lubricant will help to restore the smooth and free operation of the nozzle. However, these lubricants do not have the washout resistance and long-term performance of the silicone grease. Therefore, re-application of Break Free CLP will be needed on a regular basis. CAUTION: Aerosol lubricants contain solvents that can swell O-Rings if applied in excess. The swelling can inhibit smooth operation of the moving parts. When used in moderation, as directed, the solvents quickly evaporate without adversely swelling the O-Rings.

The nozzle can be returned to the factory for a complete checkup and re-lubrication with silicone grease

PART ONE — COUPLING DOWN

Position the nozzle at a 45-degree angle with the COUPLING end down. CLOSE the valve handle and set the pattern to STRAIGHT STREAM. Then spray a short burst into these areas:

#1 FRONT PATTERN CONTROL SEAL

Spray in between the pattern control and the barrel.

#2 PRESSURE CONTROL UNIT

Place check sticks behind baffle while shaper is in flush. Cycle baffle in and out using check sticks several times to work lubrication into o-rings.

#3 FRONT SLIDER SEAL

- Rotate shaper into FLUSH position.
- Spray down the front end of the nozzle to dribble lubricant into the clearances between the shaper and the valve body.

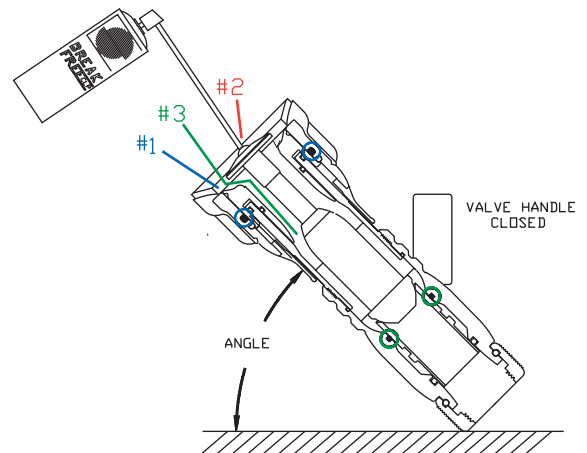

While holding nozzle at the angle, wait 30 seconds for the lubricant to penetrate into the clearances. Cycle the valve handle and rotate the shaper from straight stream to full flush several times, and then proceed to the next section.

PART TWO — COUPLING UP

Position the nozzle at a 45-degree angle with the BUMPER end down. OPEN the valve handle and set the pattern to FLUSH. Spray a short burst in these areas:

#4 REAR SHAPER SEAL

Spray down the clearance between the label and the shaper guide.

#5 REAR SLIDER SEAL

Spray into the clearance between the slider and the valve body.

#6 FLUSH MECHANISM SEAL

- With the handle on the top, spray down into the nozzle. The aerosol extension tip will help direct the spray into clearances leading to the O-Ring.
- Rotate nozzle so the valve is on the bottom and spray another short burst.

#7 DETENTS IN THE HANDLE

Spray a small amount on the detent followers located in the handle.

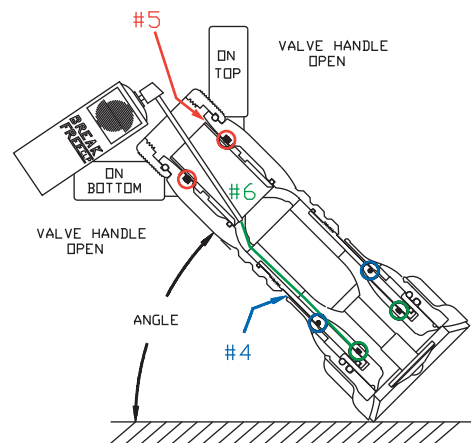

While holding nozzle at the angle, wait 30 seconds, then cycle the valve handle several times. Rotate the pattern control from straight stream to full flush several times. The pattern control should move freely and easily. The barrel cone should move forward to within 1/16" of the baffle before the shaper reaches straight stream position. Wipe off excess lubricant.

IF THIS PROCEDURE DOES NOT RESTORE SMOOTH AND FREE OPERATION OF ALL THE MOVING PARTS, THEN FACTORY SERVICE IS NEEDED. • 24-HOUR HOT LINE — 800-348-2686 • www.tft.com

11.2 IMPULSE TRIGGER VALVE LUBRICATION

- 1) Insert tube from BreakFree into drain hole in pistol grip.
- 2) With nozzle upside down spray a 2 second burst into the pistol grip. Holding a rag around the tube here can help keep excess BreakFree from the outside of the nozzle.
- 3) Keep nozzle upside down for at least 10 seconds to allow the BreakFree to flow into the valve area.
- 4) Check for smooth and free operation of the trigger. Repeat a second time if needed.

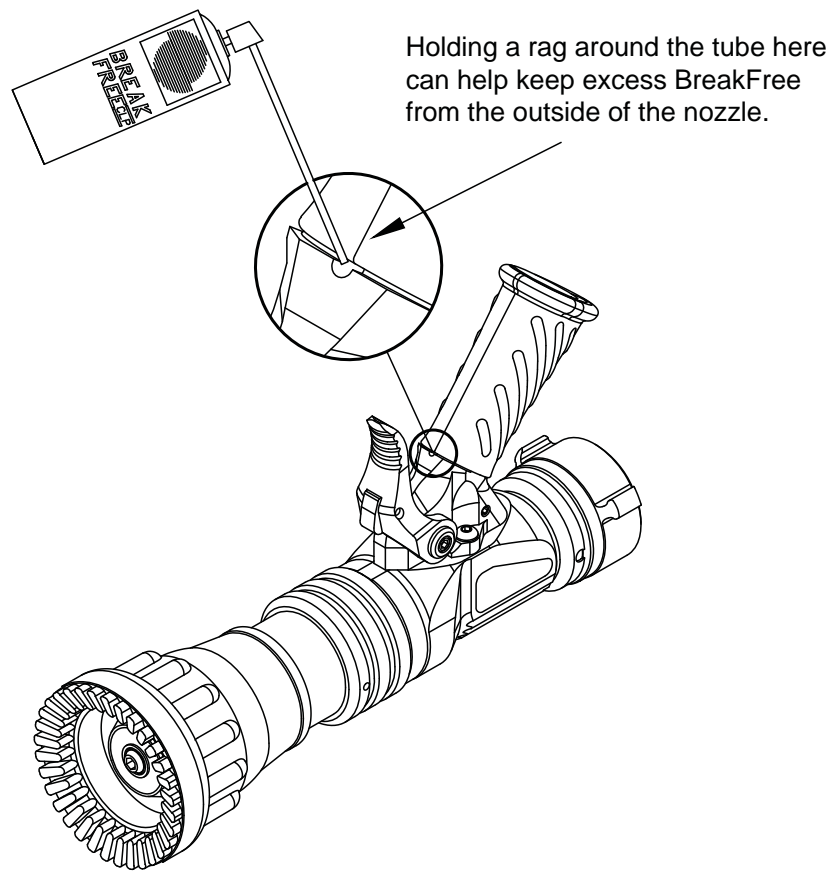

**If this procedure does not restore trigger operation then factory service is needed.
24 hour Technical Service and Support - 800-348-2686 - www.tft.com**

11.3 SERVICE TESTING

In accordance with NFPA 1962 (2013), nozzles must be tested a minimum of annually. Nozzles failing any part of this test must be removed from service, repaired and retested upon completion of the repair.

11.3.1 HYDROSTATIC TESTING

Each nozzle with a shut off mechanism shall be tested in the following manner.

- 1. The nozzle shall be placed in a device capable of holding it and the shut off shall be closed.*
- 2. A device capable of exerting a hydrostatic pressure of 300 psi (2070 kPa) or 1.5 times the maximum operating pressure, whichever is higher, shall be attached to the nozzle.*
- 3. All air shall be bled from the system.*
- 4. The gage pressure shall be increased by 50 psi (3.5 bar or 345 kPa) increments, held for 30 seconds at each pressure up to the maximum pressure for which the nozzle is being tested, and then held for one minute without leakage.*
- 5. There shall be no sign of leakage through the valve or shut off.*

11.3.2 FLOW TESTING

Flow testing must be conducted in the following manner.

- 1. The nozzle shall be mounted so that the flow rate and pressure through the nozzle and the pressure at the inlet can be accurately measured.*
- 2. With the shut off fully open, the inlet pressure shall be adjusted to the rated pressure ± 2 percent.*
- 3. The valve or shut off and pattern controls shall be operated through their full range of motion at 100 psi (6.9 bar or 690 kPa) with no signs of leaking, binding or other problems.*
- 4. Evaluate the flow of nozzles as defined by NFPA 1964 in the following manner:*
 - Automatic (Constant Pressure) Spray Nozzles*
 - 1. The flow rate shall slowly be increased to the maximum rated flow, and the minimum and maximum pressures through the flow range recorded.*
 - 2. Nozzles shall maintain their rated pressure ± 15 psi (± 1 bar or ± 100 kPa) throughout the rated flow range.*

11.3.3 RECORDS

A record of testing and repairs must be maintained from the time the nozzle is purchased until it is discarded. Each TFT nozzle is engraved with a unique serial number which, if so desired, can be used to identify nozzle for documentation purposes.

The following information, if applicable, must be included on the test record for each nozzle:

- 1. Assigned identification number*
- 2. Manufacturer*
- 3. Product or model designation*
- 4. Vendor*
- 5. Warranty*
- 6. Hose connection size*
- 7. Maximum operating pressure*
- 8. Flow rate or range*
- 9. Date received and date put in service*
- 10. Date of each service test and service test results*
- 11. Damage and repairs, including who made the repairs and the cost of repair parts*
- 12. Reason removed from service*

NFPA 1962: Standard for the care, use, inspection, service testing, and replacement of fire hose, couplings, nozzles and fire hose appliances. (2013 ed., Section 5.5.4). Quincy, MA: National Fire Protection Agency.

11.4 REPAIR

Factory service is available with repair time seldom exceeding one day in our facility. Factory-serviced nozzles are repaired by experienced technicians, wet tested to original specifications, and promptly returned. Repair charges for non-warranty items are minimal. Any returns should include a note as to the nature of the problem and whom to reach in case of questions.

Repair parts and service procedures are available for those wishing to perform their own repairs. Task Force Tips assumes no liability for damage to equipment or injury to personnel that is a result of user service. Contact the factory or visit the web site at www.tft.com for parts lists, exploded views, test procedures and troubleshooting guides.

Performance tests shall be conducted on the nozzle after a repair, or anytime a problem is reported to verify operation in accordance with TFT test procedures. Consult factory for the procedure that corresponds to the model and serial number of the nozzle. Any equipment which fails the related test criteria should be removed from service immediately. Troubleshooting guides are available with each test procedure or equipment can be returned to the factory for service and testing.



Any alterations to the nozzle and its markings could diminish safety and constitutes a misuse of this product.

12.0 OPERATION AND INSPECTION CHECKLIST

BEFORE EACH USE the nozzle must be inspected to this checklist:

- 1) There is no obvious damage such as missing, broken or loose parts, damaged labels etc.
- 2) Debris screen is free of debris
- 3) Coupling is tight and leak free
- 4) Valve operates freely through full range and regulates flow
- 5) "OFF" position does fully shut off and flow is stopped
- 6) Nozzle flow is adequate as indicated by pump pressure and nozzle reaction
- 7) Shaper turns freely and adjusts pattern through full range
- 8) Shaper turns into full flush and out of flush with normal flow and pressure restored
- 9) Shaper detent (if so equipped) operates smoothly and positively.

BEFORE BEING PLACED BACK IN SERVICE, nozzles must be inspected to this checklist;

- 1) *All controls and adjustments are operational*
- 2) *Shut off valve (if so equipped) closes off the flow completely*
- 3) *There are no broken or missing parts*
- 4) *There is no damage to the nozzle that could impair safe operation (e.g. dents, cracks, corrosion or other defects)*
- 5) *The thread gasket is in good condition*
- 6) *The waterway is clear of obstructions*
- 7) *Nozzle is clean and markings are legible*
- 8) *Coupling is retightened properly*
- 9) *Shaper is set to desired pattern*
- 10) *Shutoff handle is stored in the OFF position*

NFPA 1962: Standard for the care, use, inspection, service testing, and replacement of fire hose, couplings, nozzles and fire hose appliances. (2013 ed., Section 5.2.2). Quincy, MA: National Fire Protection Agency.



Any nozzle failing any part of the checklist is unsafe for use and must have the problem corrected before use or being placed back into service. Operating a nozzle that has failed the checklist is a misuse of this equipment.