



HANDLINE & Dual-Force®

Maintenance and Service Procedure

**For Nozzles with: Serial # TFT-H465101 and over
or Manufactured after 12/01/2003**

INTRODUCTION

TASK FORCE TIPS AUTOMATIC: The nozzle you have purchased is your primary tool in the battle against fire. It has been manufactured with great care to give you the finest performance possible. All components are of top quality and extremely rugged. With regular inspection and attention it will serve you for many years. This publication is intended for those who prefer to perform service on their own equipment. Factory service is available and encouraged, and in most cases, seldom exceeds 24 hours one day in our facility. Factory serviced equipment is serviced by experienced workmen and fully tested before being returned. Repair charges for non-warranty items are usually minimal and all serviced equipment is promptly returned functioning to original specifications. Task Force Tips assumes no liability, expressed or implied for damage to equipment or injury to personnel that is a result of user service. **IMPORTANT:** After any maintenance or service, always check nozzle for proper operation per **INSPECTION CHECKLIST** and flow characteristics in "MANUAL: HAND-HELD AUTOMATIC NOZZLES" (LIN-030).

GENERAL INFORMATION

TOOLS REQUIRED

The following tools are required for general service to the nozzle:

- 3/32, 1/8, 7/32 and 5/16 Allen wrenches
- Dow #112 Lube/sealant
- Loctite #271 thread locking adhesive
- oxyacetylene torch
- razor knife

Additional tools needed to service the shaper are:

- strap wrench
- vise with padded jaws
- Handline / Dual-Force shaper removal clamp
(special tool TFT #THM-502)

Additional tools needed to service the pressure control are:

- dental pick
- two small probes, approximately 3/32 dia (such as a drill bit)
- drill press, 17 inch opening

THREADED JOINTS: have been secured using Loctite® #271 thread locking adhesive. Disassembly requires a minimal application of heat with an oxyacetylene torch to break the bond. The threads should be heated to approximately 450 F. Excessive heat application will cause damage to adjacent seals and labels. Replacement parts must be reinstalled using Loctite® #271, or equivalent. Small vials of Loctite® #271 for field service are available; order Part # V5010, (Loctite® #271 - Mini Dispenser).

LUBRICANTS: If parts are disassembled in an area where O-rings are present, reassemble using DOW #112 Lube on all O-rings and surfaces that the O-rings contact. Call Dow Corning® Corp. at 800-447-4700 for the name of your nearest distributor. The lube is also available through TFT as item number VSA-101. If the nozzle is not disassembled refer to Field Lubrication Procedure Section (on back).

LABEL REPLACEMENT: If labels become damaged, remove old labels with a razor knife. Remove adhesive with acetone or methyl ethyl ketone. Surface must be clean, dry and free from grease. Carefully apply new label.

ORDERING PARTS: Always specify the serial number of the nozzle when ordering parts. The serial number is found on the back of the nozzle next to the coupling. Be sure to use complete DESCRIPTION and ORDER #, as printed on parts list. All requests for couplings must specify thread size. Pricing information will be given at time of order. Parts and Repair Kits may be purchased on-line at www.tft.com

BACK END

COUPLING AND BASE SERVICE PROCEDURE

TOOLS REQUIRED

- 1/8, 5/16 Allen(hex) wrench
- Loctite #271 thread locking adhesive
- oxyacetylene torch

GENERAL: Occasional replacement of hose gaskets is recommended. Replace GASKET GRABBER [13c or 3b] if severe impact has caused damage. Coupling service kits which include all hardware and Loctite® #271 are available for all standard 1.5" or 2.5" couplings. Special configurations or model changes to a nozzle can be made by selecting the desired coupling or base. Couplings with special or standard threads are interchangeable and may be exchanged on new nozzles. Please specify desired threads when ordering.

COUPLING AND BLITZ BASE REMOVAL: All couplings and blitz bases are retained with a ball race and set screw. Heat and then remove the 1/4"-28 SOCKET SET SCREW [5c, or 1b] from the coupling using a 1/8" Allen wrench. Turn coupling so that hole faces down and rotate coupling back and forth to allow 3/16" STAINLESS STEEL BALLS [4b, 15c or 5b] to drop out. When all the balls are out of the groove, the coupling can be removed. Remove GASKET GRABBER/ debris screen [13c, or 3b] from the coupling.

NOTE: On couplings [6c, 9c, 11c and 12c] and Base [2b], O-RING 141 [14c and 4b] will be found adjacent to the GASKET GRABBER [13c, or 3b]. On coupling [2c], O-RING 151 [3c] is used. Replace and grease the proper O-Ring before installing the coupling.

COUPLING AND BLITZ BASE INSTALLATION: Insert the GASKET GRABBER/ debris screen [13c, or 3b] into the coupling, raised end pointing toward the front of the nozzle. Put the coupling onto the mating part and load the correct number of balls into the ball groove (SEE PARTS LIST ON EXPLODED VIEW OF NOZZLE TO DETERMINE CORRECT NUMBER OF STAINLESS STEEL BALLS [4c, 15b or 5b] FOR YOUR COUPLING). Insertion of the balls is easier if the coupling is rotated slightly back and forth as the balls are loaded. Apply Loctite® #271 and install proper 1/4"-28 SOCKET SET SCREW [5c, or 1b]. The set screw should be flush with the surface of the coupling. If the coupling is difficult to turn, or feels rough when turned, the set screw is in too far. Back set screw off a turn or so and try again. If the feel is still not correct, recheck the number of balls in the coupling. On TIP ONLY COUPLINGS and BLITZ BASES run the screw into the slot on the ball groove until it bottoms out without applying pressure.

TIP ONLY BASE SERVICE: The TIP ONLY BASE [8b] is attached to the TIP ONLY BARREL ASSEMBLY [7f] by a threaded joint which is retained by Loctite® #271. Apply heat to the knurled rib nearest the front of the nozzle. Damage to seals and labels can be reduced by protecting them with a wet cloth. The TIP ONLY BASE [8b] can now be unscrewed. Remove and replace O-RING 143 [9b]. Clean all threads, apply Loctite® #271 to threads and screw together.

TWIST TYPE VALVE SERVICE PROCEDURE

STO SLEEVE SERVICE: To remove the STO SLEEVE [14b], first heat and remove the CAM SCREWS [15b] and DETENT SCREWS [16b]. The detent screws contain SPRINGS [18b] and BALLS [17b]. Then, STO SLEEVE [14b] can be slid off. Service to interior STO valve should be done prior to reinstalling STO sleeve. Inspect O-RINGS [19b] and replace if damaged. Installation is reverse of removal. Before reassembly, grease O-Rings. Clean screw threads and apply Loctite® #271.

STO VALVE SERVICE: Heat the back end of the STO BASE [20b] with a torch and unscrew the STO TAIL PIECE [11b]. The STO SLIDER [13b] may now be removed. Inspect and replace any damaged O-RINGS [9b, and 12b]. Grease O-Rings, clean threads and use Loctite® #271 upon reassembly. Refer to SLIDE VALVE SERVICE PROCEDURE for Valve Plug Replacement, Valve Shutoff Adjustment, and Valve Adjustment for Severe Cold.

SLIDE VALVE SERVICE PROCEDURE

Tools Required:

- 3/32" Allen (hex) wrench
- 7/32" Allen (hex) wrench
- 5/16" Allen wrench Ball End
- Flat Screw Driver
- Mallet
- DOW #112 Lube

BOLT-ON PISTOL GRIP REMOVAL: PISTOL GRIP [19v] is held on by a SOCKET HEAD CAP SCREW [21v]. Remove screw with a 5/16" Ball Driver Allen wrench. To reinstall, clean thread and apply Loctite® #271. Tighten screw to 95 in-lbs.

VALVE PLUG REPLACEMENT: After removing back end, VALVE PLUG [17v, 10b, or 24b] is removed by pulling straight back. New valve plug can be installed using a mallet.

VALVE SHUTOFF ADJUSTMENT: Shutoff valve is adjusted by the threads between the valve body and the front end of the nozzle. While holding the VALVE HANDLE [3v] against stops in the OFF position, screw front end into the valve body until contact is made with the VALVE PLUG [17v]. Open handle to ON position to remove contact. Screw the front end in 1/12 turn further to give the valve shutoff compression. Thread in both SET SCREWS [12v] until they bottom out, without applying pressure. In an alternating fashion continue turning in set screws until tight.

VALVE ADJUSTMENT FOR SEVERE COLD: To help prevent hose line freezing in cold climates, the valve may be adjusted for intentional leakage by unscrewing the front end slightly. The valve may then be returned to normal adjustment for complete shut off during warm weather as stated above.

SLIDE VALVE DISASSEMBLY SEQUENCE

HANDLE REMOVAL: Remove both BUTTON HEAD CAP SCREWS [6v] from VALVE HANDLE [3v] using a 7/32" Allen wrench. Slide CAM and SAFETY PINS [4v and 5v] out of handle by gently prying about 3/8" apart the handle and the valve body using a flat screw driver. To remove the handle, pull upwards while containing the DETENT BALLS [7v] and SPRINGS [8v] to prevent their loss. Service to interior valve parts should be done prior to reinstalling handle.

SLIDER AND SEAL REMOVAL: Remove #10-32 x 1/4" SOCKET SET SCREWS [12v] from the VALVE ASSEMBLY [11v] using a 3/32" Allen wrench. Unscrew front portion of nozzle from valve. SLIDER [15v] can now be pulled out from the front of valve. Remove and inspect O-RINGS [13v, 14v and 16v]. Replace O-Rings if they are damaged.

SLIDE VALVE ASSEMBLY SEQUENCE

SLIDER AND SEAL INSTALLATION: Insert O-RINGS [13v, 14v and 16v] into the proper grooves in the valve body. Check SLIDER [15v] for any raised metal at groove area. Replace if necessary. Lubricate O-Rings and slider with DOW #112 Lube. Push slider into the valve body.

HANDLE INSTALLATION: Insert DETENT SPRINGS [8v] and DETENT BALLS [7v] into the handle lugs. While holding balls in place, snap the HANDLE [3v] into place with offset holes FORWARD. Carefully align the groove on SLIDER [15v] with offset hole in VALVE DISCS [9v] and with offset hole in handle. Slide SAFETY PIN [5v] into offset hole in handle. Push down into engagement with groove in slider, until head of pin is flush with handle. Repeat procedure for CAM PIN [4v]. Insert BUTTON HEAD SCREWS [6v] through the lower handle holes. Thread each into corresponding center trunnion hole. Tighten HANDLE SCREWS [6v] securely with a torque value of 100 in-lbs (11.3 N m). Handle should click firmly and smoothly into all detent positions and the slider should move back and forth smoothly. The force to move handle should be between 5 lbs and 13 lbs applied at top center of handle.

FRONT END

SHELL SERVICE PROCEDURE

SHAPER REMOVAL: The rubber bumper is permanently bonded onto the stream shaper as a single unit referred to as the SHAPER [10f]. The shaper is attached to the SHAPER GUIDE [4f, or 5f] by a threaded joint that is retained by Loctite® #271. Grip rear portion of the nozzle in a vise with padded jaws, or clamp SHAPER GUIDE [4f, or 5f] using TFT special tool TH502 held in a vise. Direct a hot narrow flame around the rear portion of the shaper and heat for approximately 20 seconds. Damage to BUMPER [10f] and LABELS [1f, 2f, or 6f] can be reduced by protecting them with a wet cloth. Use a strap wrench to unscrew the shaper from the shaper guide. Remove the shaper. Inside the shaper are (48) 13/16" ACETAL BALLS [8f], some of which may fall free as the Shaper is removed. If Shaper is to be reused, clean ball track and replace 336 O-RING [9f] if damaged.

SERVICE TO CAM GROOVES AND BALLS: When Shaper is removed, check to see if the stream shaping GUIDE BALLS [3f] and CAM GROOVES [7f - part of BARREL CONE ASSEMBLY] are damaged. Replace Balls if sheared or missing. If the CAM GROOVES are badly damaged, the BARREL CONE ASSEMBLY should also be replaced.

BARREL CONE ASSEMBLY SERVICE: This assembly is permanent and cannot be taken apart. Check to ensure that the flush spring is not damaged by pushing down on the Barrel Cone with both hands (about 50 lbs force). The Barrel Cone Assembly should be replaced if the Barrel Cone does not push down or spring back up by itself. Lightly grease the CAM GROOVES before re-installing the SHAPER GUIDE.

SHAPER INSTALLATION: Install 336 O-RING [9f] in front groove of SHAPER [10f]. Grease the seal and ball groove heavily. Place (48) 13/16" ACETAL BALLS [8f] into greased ball groove. Apply Loctite® #271 to male thread on SHAPER GUIDE [4f, or 5f]. Start shaper onto SHAPER GUIDE threads. Place three SHAPER GUIDE BALLS [3f] into the grooves on barrel and screw down shaper until threads bottom out.

PRESSURE CONTROL SERVICE PROCEDURE

Tools Required:

- 1/4 Allen wrench (10" Long)
- 1/4 Allen wrench (regular length)
- Mallet

PRESSURE CONTROL REPLACEMENT: The pressure control may be removed and replaced as a unit by following the procedure in the PRESSURE CONTROL REMOVAL and INSTALLATION AND INITIAL OPENING ADJUSTMENT sections.

NOTICE: The Pressure Control Unit is part of the BARREL ASSEMBLY [7f]. This unit is factory calibrated and sealed. Service on this unit is best performed at the factory using special tooling and equipment. In the unlikely event that this unit should need service, it is highly recommended that you return the complete nozzle to the factory for repairs OR replace the entire PRESSURE CONTROL UNIT. DO NOT ATTEMPT TO DISASSEMBLE THE PRESSURE CONTROL UNIT! Task Force Tips will assume NO liability for damage or injury resulting from attempts to disassemble or repair the Pressure Control Unit.

PRESSURE CONTROL REMOVAL: To remove the CONTROL UNIT first separate the front end from the nozzle, then remove the VALVE PLUG (106, 24b or 17v). Loosen and remove the shaft locking SCREW (1p) with a 3/16 allen wrench. Insert a 7/32 Allen wrench into the front of the shaft and screw the shaft out of the barrel assembly. LOCKING SLEEVE (2p) is removed by pushing it forward and out of BARREL ASSEMBLY (7f) with a punch. Note: LOCKING SLEEVE may require light tapping with a hammer to remove.

PRESSURE CONTROL INSTALLATION AND INITIAL OPENING ADJUSTMENT: To install the CONTROL UNIT, lightly grease I.D. and O.D. of locking sleeve and also threads of the screw. Place LOCKING SLEEVE (2p) with hollow end forward onto back of shaft, thread finger tight. Note: If old LOCKING SLEEVE is reused it may require light tapping with a hammer and punch to install. Screw CONTROL UNIT (with pressure control parts installed) into barrel assembly. Insert a 7/32 Allen wrench into front of shaft and turn in until baffle just touches BARREL CONE (7f) then turn back between 1/2 and 3/4 of a turn (opening gap of .026/.036 inches or .66/.91mm). Keep Allen wrench in shaft to assure that shaft doesn't turn and tighten screw against locking sleeve, to approximately 180 in-lbs.

IMPORTANT: Always flow test after adjusting. Nozzle pressure and flow requirements are shown on the following table:

INITIAL OPENING at 40 PSI (2.8 BAR)

FLOW (MIN)	FLOW (MAX)	Opening Gap (REF)
38 GPM	58 GPM	.026/.036in
(144L/MIN)	(204 L/MIN)	(.66/.91mm)

NOZZLE PRESSURE NOZZLE PRESSURE

	AT 95 GPM	AT 250 GPM
100 PSI MODEL	85 PSI +/- 6	99 PSI +/- 6
75 PSI MODEL	60 PSI +/- 6	80 PSI +/- 6

DUAL-FORCE KNOB REMOVAL: To remove the DUAL-FORCE KNOB [8p] from the BAFFLE [4p]:

- 1) Turn knob to standard setting.
- 2) Turn the SHAPER [10f] back to full flush.
- 3) Insert a small probe (such as a 1/16" drill bit) into the smaller of the two holes on top of the knob.
- 4) Simultaneously push down with probe while turning knob clockwise (when viewed from the front). Once knob turns a little, the probe may be removed.
- 5) Turn knob clockwise until it hits a stop. (about 25 degrees).
- 6) Pull knob to remove from baffle.

DUAL-FORCE KNOB INSTALLATION:

- 1) Place the label (HXD752) into the knob (HXD560).
- 2) Add o-ring (VO-005) to o-ring groove on top of the baffle (HXD561) and groove.
- 3) Place the knob onto the Baffle fully.
- 4) Install the Compression Spring (VM4195) and Torton Ball (VB156TO).
- 5) Push down on Compression Spring and Torton Ball and twist the Knob counter-clockwise till it clicks in place.
- 6) Check for smooth operation between standard and low pressure settings.

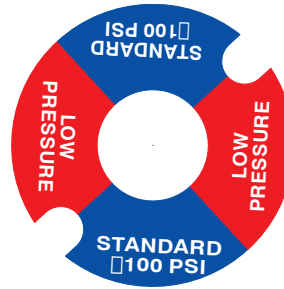

HXD752 Label
FIGURE 1

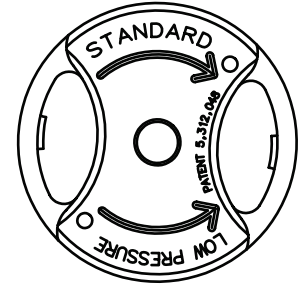

HXD560 Knob
FIGURE 2

PROBLEMS:

If you have any questions or problems, please call for assistance.

(800) 348-2686 • (219) 462-6161 • FAX (219) 464-0620

TASK FORCE TIPS INC. - www.tft.com

3701 Innovation Way • Valparaiso, IN 46383-9327

EXPLODED VIEWS and PARTS LISTS

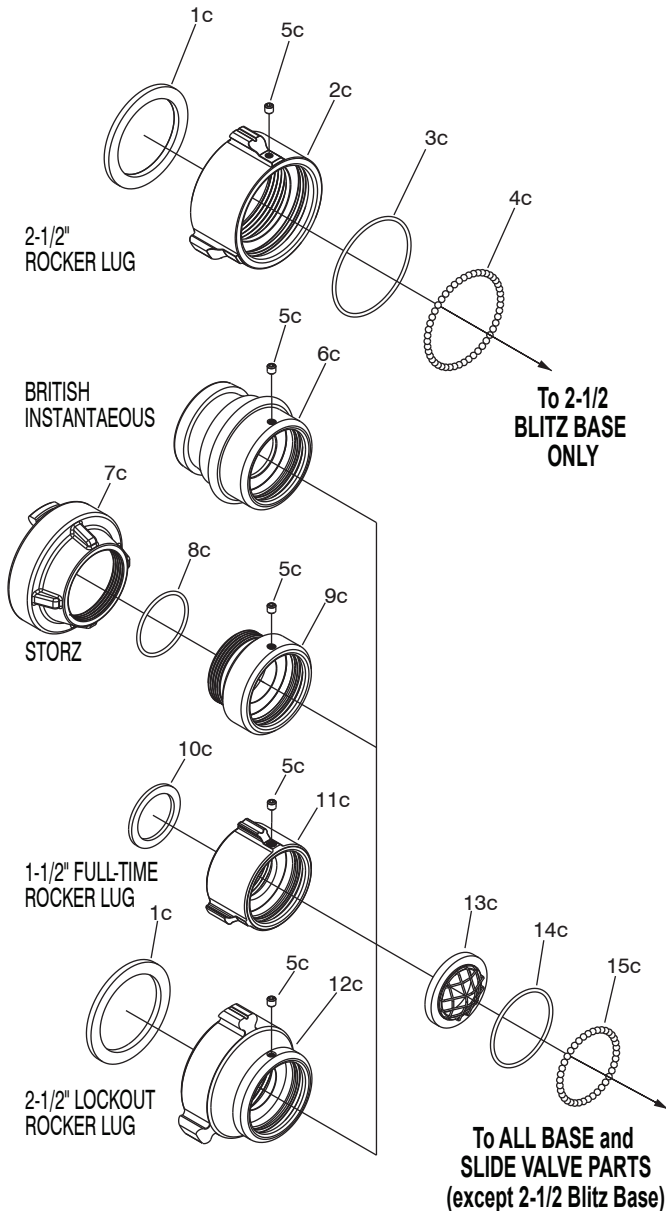

INDEX	DESCRIPTION	QTY	PART #
1c	2.5" HOSE GASKET	1	V3190
2c	2.5" ROCKER LUG COUPLING	1	P197
3c	O-RING-151	1	VO-151
4c	3/16 SS BALLS	48	V2120
5c	1/4-28X3/8 SOCKET SET	1	VT25-28SS250
6c	2.5" BIC COUPLING	1	H687
7c	52 MM STORZ COUPLING	1	H686
8c	O-RING-134	1	VO-134
9c	2.0" BSP MALE SWIVEL	1	H685
10c	1.5" COUPLING GASKET	1	V3130
11c	1.5" ROCKER LUG COUPLING	1	H694
12c	2.5" ROCKER LUG COUPLING	1	P198
13c	1.5" HARD GASKET GRABBER		
	SINGLE	1	H730-60D
	DUAL FORCE	1	HD730-60D
14c	O-RING-141	1	VO-141
15c	3/16 SS BALLS	38	V2120

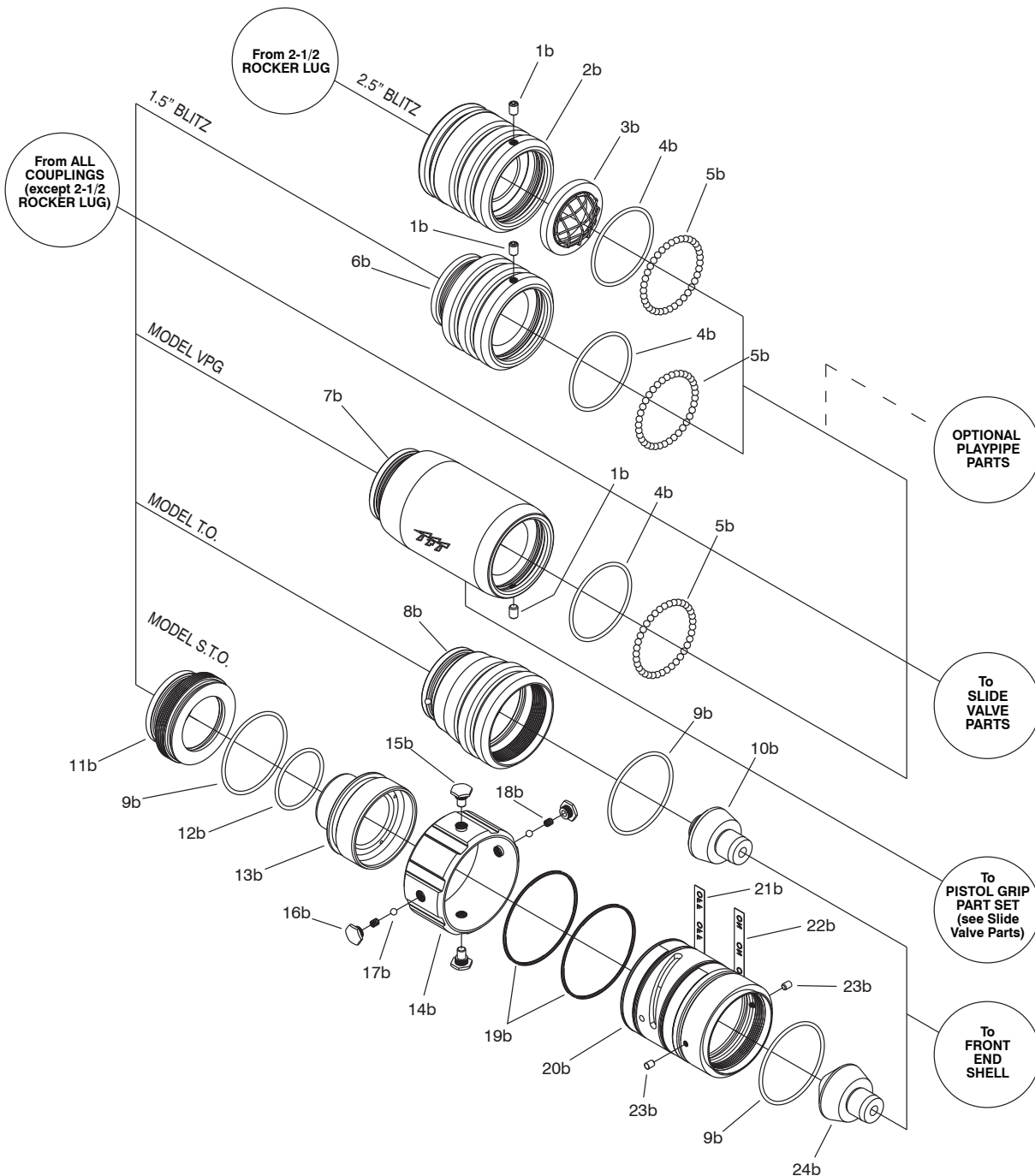

BASES, TIP ONLY and TWIST TYPE

#	DESCRIPTION	QTY	PART #
1b	1/4-28 X 3/8 SOCKET SET SCREW	1	VT25-28SS375
2b	2.5" BLITZ BASE	1	H675
3b	1.5" HARD GASKET GRABBER	1	H730-60D
		1	HD730-60D
4b	O-RING-141	1	VO-141
5b	3/16 SS BALLS	37	V2120
6b	1.5" BLITZ BASE	1	H674
7b	PISTOL GRIP BODY - LONG	1	H692
8b	TIP ONLY BASE	1	H670
9b	O-RING-143	2	VO-143
10b	TIP ONLY PLUG	1	HX591
11b	TAIL PIECE - STO	1	HD662
12b	O-RING-132	1	VO-132

#	DESCRIPTION	QTY	PART#
13b	SLIDER - STO	1	HD660
14b	SLEEVE - STO	1	HD668
15b	CAM SCREW	2	HD780
16b	DETENT SCREW	2	HD785
17b	3/16" TORLON BALL	2	V2120-TORLON
18b	DETENT SPRING - STO	2	VM4200
19b	QUAD-RING-039	2	VOQ-4039
20b	BASE - STO	1	HD665
21b	OFF LABEL - RED	1	HD755
22b	ON LABEL - BLUE	1	HD750
23b	10-32 X 1/4 SET SCREW-ND PATCH	2	VT10Y32SS250
24b	VALVE PLUG - STO	1	HXD591

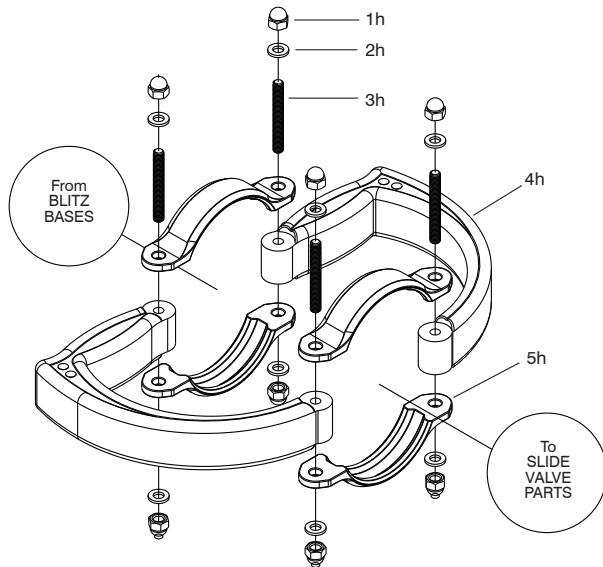

PLAYPIPE HANDLE

#	DESCRIPTION	QTY	PART#
1h	1/4-20 SS ACORN NUT	8	VT25E20AC
2h	WASHER	8	VW500X265-63
3h	1/4-20 X 2 STUD FULL THREAD	4	VT25-20ST2.0
4h	PLAYPIPE HANDLE	2	P220
5h	BLITZ BRACKET	4	H676

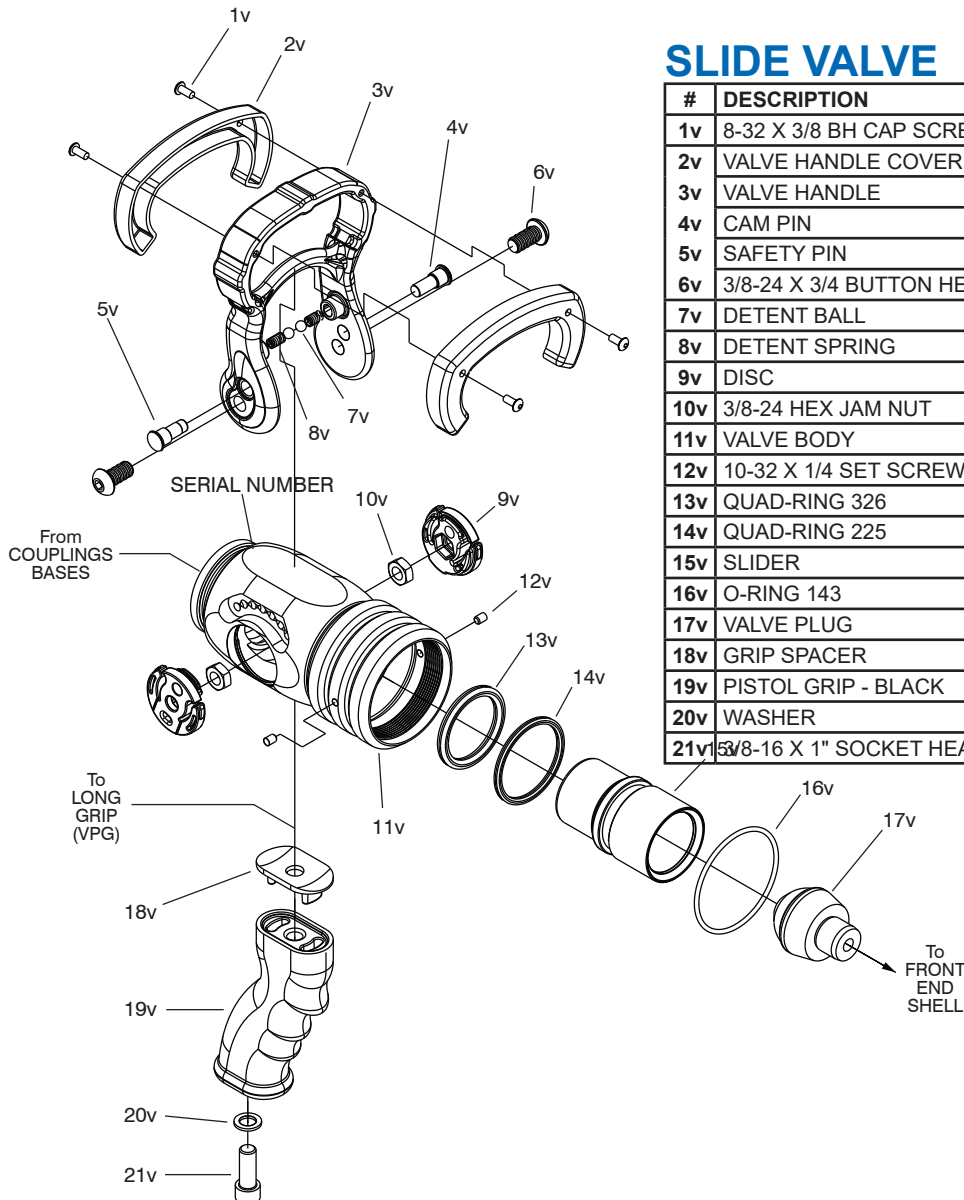

SLIDE VALVE

#	DESCRIPTION	QTY	PART#
1v	8-32 X 3/8 BH CAP SCREW	4	VT08-E32BH375
2v	VALVE HANDLE COVER	2	HM625-BLK
3v	VALVE HANDLE	1	HX620
4v	CAM PIN	1	HX630
5v	SAFETY PIN	1	HX635
6v	3/8-24 X 3/4 BUTTON HEAD SCREW	2	VT37E24BH750
7v	DETENT BALL	2	VB243TO
8v	DETENT SPRING	2	HM770
9v	DISC	2	HX640
10v	3/8-24 HEX JAM NUT	2	VT37-24JNT
11v	VALVE BODY	1	HX600
12v	10-32 X 1/4 SET SCREW-ND PATCH	2	VT10Y32SS250
13v	QUAD-RING 326	1	VOQ-4326
14v	QUAD-RING 225	1	VOQ-4225
15v	SLIDER	1	H660
16v	O-RING 143	1	VO-143
17v	VALVE PLUG	1	HX590
18v	GRIP SPACER	1	HM693-H
19v	PISTOL GRIP - BLACK	1	HM692-BLK
20v	WASHER	1	VM4901
21v	3/8-16 X 1" SOCKET HEAD CAP SCREW	1	VT37-16SH1.0

SHELL FRONT END

#	DESCRIPTION	QTY	PART#
2f	NAME LABEL HANDLINE - 100 PSI	1	HX745
	NAME LABEL HANDLINE - 75 PSI	1	HX745L
	NAME LABEL DUAL-FORCE 100/55 PSI	1	HXD745
	NAME LABEL DUAL-FORCE 75/45 PSI	1	HXD745L
3f	GUIDE BALLS	3	VB344TO
4f	SHAPER GUIDE	1	HXD510
6f	BARREL LABEL - SINGLE PRESS	1	H740
	DUAL-FORCE	1	HD740
7f	BARREL ASSEMBLY - HANDLINE	1	HX850-KIT
8f	3/16" BALLS	48	V2115
9f	O-RING 336	1	VO-336
10f	SHAPER WITH BUMPER	1	H500

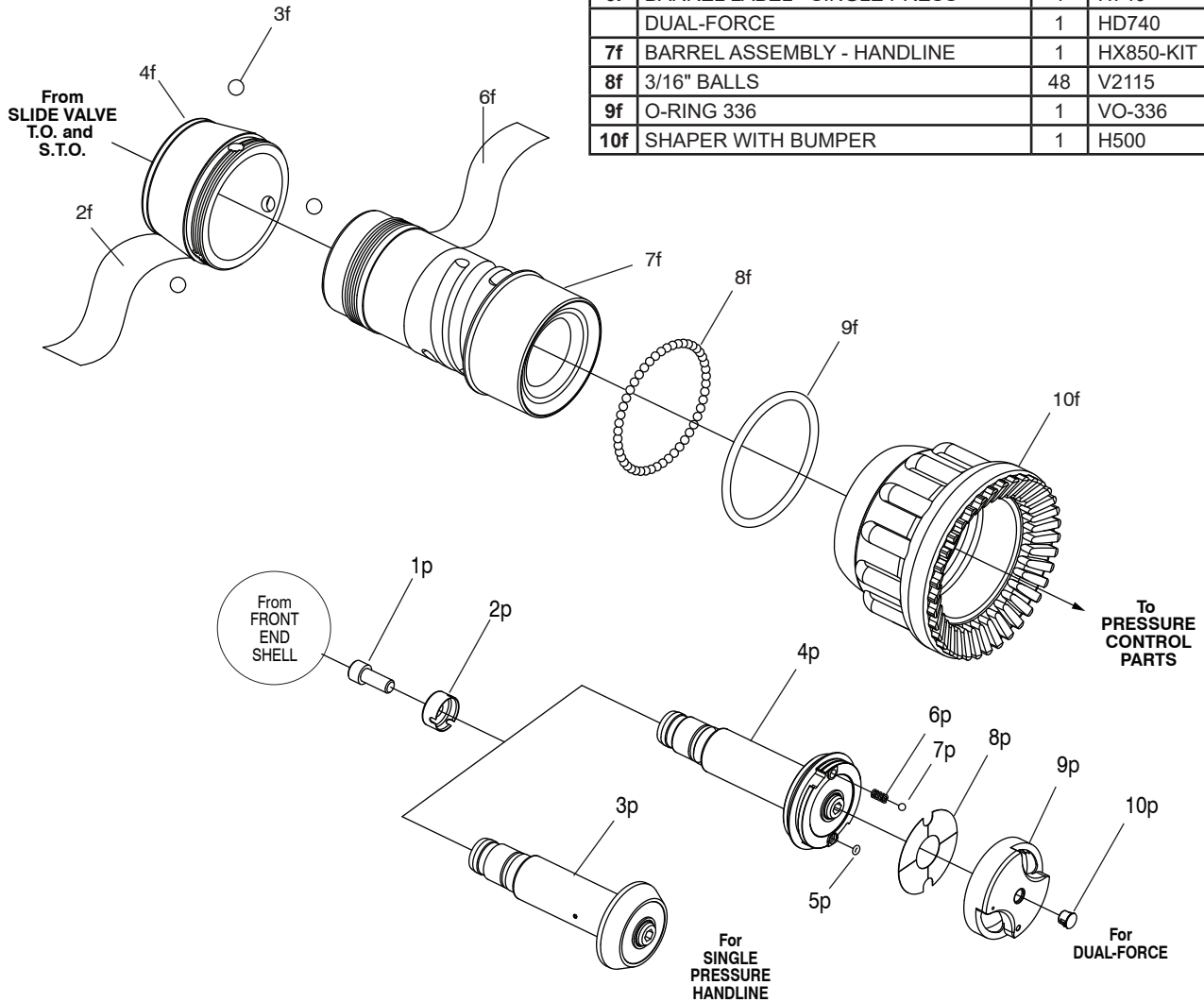

PRESSURE CONTROL

#	DESCRIPTION	QTY	PART#
1p	5/16-18 X 3/4 SOCKET HEAD CAP SCREW	1	VT31-18SH750
2p	LOCKING SLEEVE	1	HX571
3p	PRESSURE CONTROL ASSEMBLY		
	HANDLINE 100 PSI	1	HX840-KIT
	HANDLINE 75 PSI	1	HX840-75-KIT
4p	PRESSURE CONTROL ASSEMBLY		
	DUAL FORCE 100/55 PSI	1	HXD840-KIT
	DUAL-FORCE 75/45 PSI	1	HXDL840-KIT
5p	O-RING 005	2	VO-005
6p	SPRING	1	VM4195
7p	5/32" TORLON BALL	1	VB156TO
8p	KNOB LABEL - 100 PSI STANDARD	1	HXD752
	KNOB LABEL - 75 PSI STANDARD/LOW	1	HXD752L
9p	KNOB	1	HXD560
10p	DOME PLUG	1	VM4124



PERSONAL RESPONSIBILITY CODE

The member companies of FEMSA that provide emergency response equipment and services want responders to know and understand the following:

1. Firefighting and Emergency Response are inherently dangerous activities requiring proper training in their hazards and the use of extreme caution at all times.
2. It is your responsibility to read and understand any user's instructions, including purpose and limitations, provided with any piece of equipment you may be called upon to use.
3. It is your responsibility to know that you have been properly trained in Firefighting and /or Emergency Response and in the use, precautions, and care of any equipment you may be called upon to use.
4. It is your responsibility to be in proper physical condition and to maintain the personal skill level required to operate any equipment you may be called upon to use.
5. It is your responsibility to know that your equipment is in operable condition and has been maintained in accordance with the manufacturer's instructions.
6. Failure to follow these guidelines may result in death, burns or other severe injury.



Fire and Emergency Manufacturers and Service Association
P.O. Box 147, Lynnfield, MA 01940 • www.FEMSA.org

WARRANTY

Task Force Tips, Inc., 3701 Innovation Way, Valparaiso, Indiana 46383-9327 ("TFT") warrants to the original purchaser of its Ultimatic, Mid-Matic, and Handline series nozzles ("equipment"), and to anyone to whom it is transferred, that the equipment shall be free from defects in material and workmanship during the five (5) year period from the date of purchase.

TFT's obligation under this warranty is specifically limited to replacing or repairing the equipment (or its parts) which are shown by TFT's examination to be in a defective condition attributable to TFT. To qualify for this limited warranty, the claimant must return the equipment to TFT, at 3701 Innovation Way, Valparaiso, Indiana 46383-9327, within a reasonable time after discovery of the defect. TFT will examine the equipment. If TFT determines that there is a defect attributable to it, TFT will correct the problem within a reasonable time. If the equipment is covered by this limited warranty, TFT will assume the expenses of repair.

If any defect attributable to TFT under this limited warranty cannot be reasonably cured by repair or replacement, TFT may elect to refund the purchase price of the equipment, less reasonable depreciation, in complete discharge of its obligations under this limited warranty. If TFT makes this election, claimant shall return the equipment to TFT free and clear of any liens and encumbrances.

This is a limited warranty. The original purchaser of the equipment, any person to whom it is transferred, and any person who is an intended or unintended beneficiary of the equipment, shall not be entitled to recover from TFT any consequential or incidental damages for injury to person and/or property resulting from any defective equipment manufactured or assembled by TFT. It is agreed and understood that the price stated for the equipment is in part consideration for limiting TFT's liability. Some states do not allow the exclusion or limitation of incidental or consequential damages, so the above may not apply to you.

TFT shall have no obligation under this limited warranty if the equipment is, or has been, misused or neglected (including failure to provide reasonable maintenance) or if there have been accidents to the equipment or if it has been repaired or altered by someone else.

THIS IS A LIMITED EXPRESS WARRANTY ONLY. TFT EXPRESSLY DISCLAIMS WITH RESPECT TO THE EQUIPMENT ALL IMPLIED WARRANTIES OF MERCHANTABILITY AND ALL IMPLIED WARRANTIES OF FITNESS FOR A PARTICULAR PURPOSE. THERE IS NO WARRANTY OF ANY NATURE MADE BY TFT BEYOND THAT STATED IN THIS DOCUMENT.

This limited warranty gives you specific legal rights, and you may also have other rights which vary from state to state.

ANSWERS TO YOUR QUESTIONS

We appreciate the opportunity of serving you and making your job easier. If you have any problems or questions, our toll-free "Hydraulics Hotline", 800-348-2686, is normally available to you 24 hours a day, 7 days a week.

Visit www.tft.com. Go to Literature, Service Procedures and then Service Poster to view a full-size version of this booklet.