

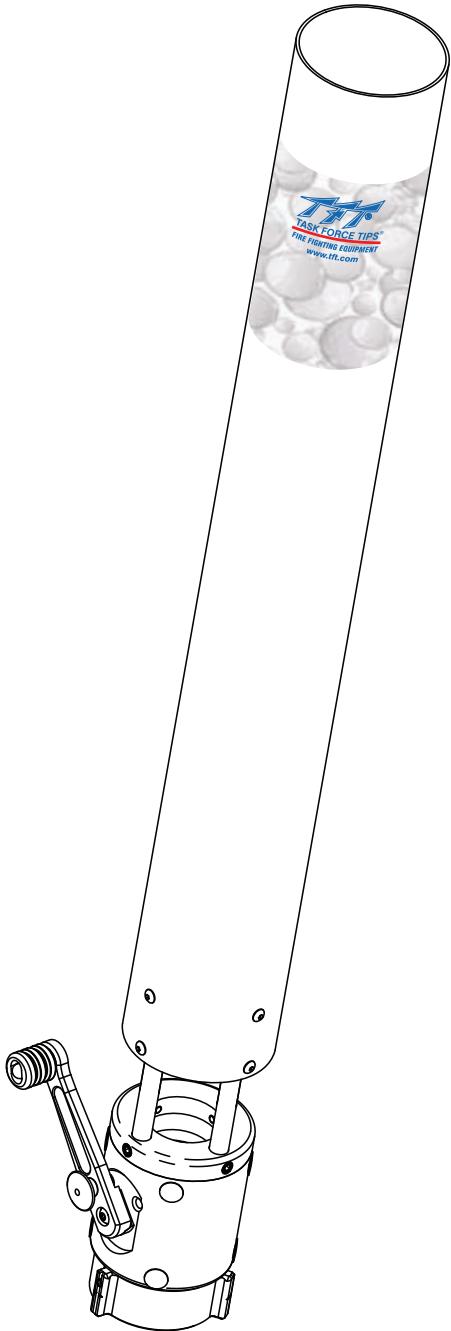

# MANUAL: Dual Flow LX Foam Nozzle

## INSTRUCTIONS FOR SAFE OPERATION AND MAINTENANCE

**⚠ WARNING** Read instruction manual before use. Operation of the Dual Flow LX Foam Nozzle without understanding the manual and receiving proper training can result in injury and is a misuse of this equipment. This manual should be kept available to all operating and maintenance personnel.



MECHANICAL SPECIFICATIONS		
	US	METRIC
WEIGHT	24 lbs	11 kg
LENGTH	5 ft	1.5 m
LOW FLOW SETTING	K=66 790 gpm @ 145 psi	50 l/s @ 1000 kPa 3000 l/min @ 10 bar
HIGH FLOW SETTING	K=132 1580 gpm @ 145 psi	100 l/s @ 1000 kPa 6000 l/min @ 10 bar
MAX OPERATING PRESSURE	200 psi	1400 kPa 14 bar
OPERATING TEMP RANGE	-25 to 135°F	-32 to 57°C
MONITOR COMPATIBILITY	MONSOON 2000 3.5" OUTLET	
MODEL	FX100-NN	

### ⚠ DANGER

#### PERSONAL RESPONSIBILITY CODE

The member companies of FEMSA that provide emergency response equipment and services want responders to know and understand the following:

1. Firefighting and Emergency Response are inherently dangerous activities requiring proper training in their hazards and the use of extreme caution at all times.
2. It is your responsibility to read and understand any user's instructions, including purpose and limitations, provided with any piece of equipment you may be called upon to use.
3. It is your responsibility to know that you have been properly trained in Firefighting and /or Emergency Response and in the use, precautions, and care of any equipment you may be called upon to use.
4. It is your responsibility to be in proper physical condition and to maintain the personal skill level required to operate any equipment you may be called upon to use.
5. It is your responsibility to know that your equipment is in operable condition and has been maintained in accordance with the manufacturer's instructions.
6. Failure to follow these guidelines may result in death, burns or other severe injury.



Fire and Emergency Manufacturers and Service Association  
P.O. Box 147, Lynnfield, MA 01940 • www.FEMSA.org

**TASK FORCE TIPS LLC**  
MADE IN USA • tft.com

3701 Innovation Way, Valparaiso, IN 46383-9327 USA  
800-348-2686 • 219-462-6161 • Fax 219-464-7155

# TABLE OF CONTENTS

- 1.0 MEANING OF SAFETY SIGNAL WORDS
- 2.0 SAFETY
- 3.0 INTRODUCTION
- 4.0 FOAM TYPE, CONCENTRATION AND PROPORTIONING
- 5.0 ATTACHMENT TO THE MONITOR
- 6.0 USE OF DUAL FLOW LX FOAM NOZZLE
- 7.0 USE WITH SALT WATER
- 8.0 BASIC GUIDE TO FOAM SELECTION AND USE
- 9.0 EXPLODED VIEW AND PARTS LIST
- 10.0 WARRANTY
- 11.0 MAINTENANCE
  - 11.1 FIELD LUBRICATION
  - 11.2 SERVICE TESTING
    - 11.2.1 RECORDS
  - 11.3 REPAIR
- 12.0 INSPECTION CHECKLIST

## 1.0 MEANING OF SAFETY SIGNAL WORDS

A safety related message is identified by a safety alert symbol and a signal word to indicate the level of risk involved with a particular hazard. Per ANSI standard Z535.6-2011, the definitions of the four signal words are as follows:



**DANGER** indicates a hazardous situation which, if not avoided, will result in death or serious injury.



**WARNING** indicates a hazardous situation which, if not avoided, could result in death or serious injury.



**CAUTION** indicates a potentially hazardous situation which, if not avoided, could result in minor or moderate injury.



**NOTICE** is used to address practices not related to physical injury.

## 2.0 SAFETY

### **⚠ DANGER**

Lack of foam can place nozzle operator at risk of injury or death. Establish foam flow before advancing into hazardous situations. Assure against running out of foam. Check foam concentrate level periodically and keep an adequate supply on hand.

### **⚠ WARNING**

For Class B fires, lack of foam or interruption in the foam stream can cause a break in the foam blanket and greatly increase the risk of injury or death. Assure that:

- Application rate is sufficient (see NFPA 11 of foam manufacturer's recommendations)
- Enough concentrate is on hand to complete task (see NFPA for minimum duration time requirements)
- Foam logistics have been carefully planned

Allow for such things as:

- Storage of foam concentrate in a location not exposed to the hazard it protects
- Personnel, equipment, and technique to deliver foam at a rapid enough rate
- Removal of empty foam containers
- Clear path to deliver foam, as hoses and other equipment and vehicles are deployed

### **⚠ WARNING**

There are a wide variety of foam concentrates. Each user is responsible for verifying that any foam concentrate chosen to be used with this unit has been tested to assure that the foam obtained is suitable for the purpose intended.

### **⚠ WARNING**

The equipment may be damaged if frozen while containing significant amounts of water. Such damage may be difficult to detect visually. Subsequent pressurization can lead to injury or death. Any time the equipment is subject to possible damage due to freezing, it must be tested and approved for use by qualified personnel before being considered safe for use.

### **⚠ WARNING**

Improper use of foam can result in injury, death, or damage to the environment. Follow foam concentrate manufacturer's instructions and fire service training to avoid:

- Using wrong type of foam on a fire (i.e. Class A foam on a Class B fire)
- Mishandling of concentrates, some of which are flammable
- Plunging foam into pools of burning liquid fuels
- Causing environmental damage
- Directing foam into face

### **⚠ WARNING**

Do not use Class A foam on Class B fires or Class B foam on Class A fires. Note: Some foam concentrates are universal and can be used on Class B fires and spills and as a wetting agent on Class A fires. (Refer to foam concentrate manufacturer's recommendations for proper foam choice.)

### **⚠ WARNING**

The stream exiting the nozzle is very powerful and capable of causing injury and property damage. Make sure the nozzle is securely attached and pointing in a safe direction before water is turned on. Use care in directing the stream.

### **⚠ CAUTION**

Any alteration to the Dual Flow LX Foam Nozzle or its markings constitutes a misuse of this product and could diminish safety.

### **⚠ CAUTION**

Nozzle must be properly connected. Mismatched or damaged threads may cause nozzle to leak or uncouple under pressure and could cause injury.

### **⚠ CAUTION**

Dissimilar metals coupled together can cause galvanic corrosion that can result in the inability to unscrew the threads, or the complete loss of thread engagement over time. Per NFPA 1962, if dissimilar metals are left coupled together, an anti-corrosive lubricant should be applied to the threads. Also the couplings should be disconnected and inspected at least quarterly.

### **NOTICE**

To prevent mechanical damage, do not drop or throw equipment.

### 3.0 INTRODUCTION

In order to produce the best quality low expansion foam for fire fighting, the foam solution must be aerated by some means. The Dual Flow LX Foam Tube provides a simple means to aerate the foam as it exits the tube. The foam attachments are quickly attached or removed as the situation demands.

### 4.0 FOAM TYPE, CONCENTRATION AND PROPORTIONING

The Dual Flow LX Foam Nozzle can be used with most types of concentrate including protein, fluoroprotein, AFFF, and AR-AFFF (alcohol resistant foam). (See Section 8.0 Basic Guide to Foam Selection and Use for a summary of typical uses for various foam types.)

The foam concentrate must be proportioned into the water before the nozzle by some means, such as batch mixing, eductors or direct injection systems.

The nature of the fire hazard will determine the type of foam used, the concentration, and the desired expansion ratio. (Refer to Section 8.0 Basic Guide to Foam Selection and Use for basic guidelines.) Finished foam expansion and longevity (life) are largely dependent on the type and quality of foaming agents used in foam chemical formulations. Some foams will perform better than others when used with these devices.

### 5.0 ATTACHMENT TO MONITOR

The Dual Flow LX Foam Nozzle is attached to the nozzle by Rocker lug coupling.

### 6.0 USE OF DUAL FLOW LX FOAM NOZZLE

The Dual Flow LX Foam Nozzle has low flow and high flow settings. To switch between flows, pull the pull-pin and move the handle to the desired flow. The pull-pin locks the ball at the rated flows. There is no shutoff valve in the nozzle.

The Dual Flow LX Foam Nozzle comes standard with a 3.5"NH female rocker lug coupling.

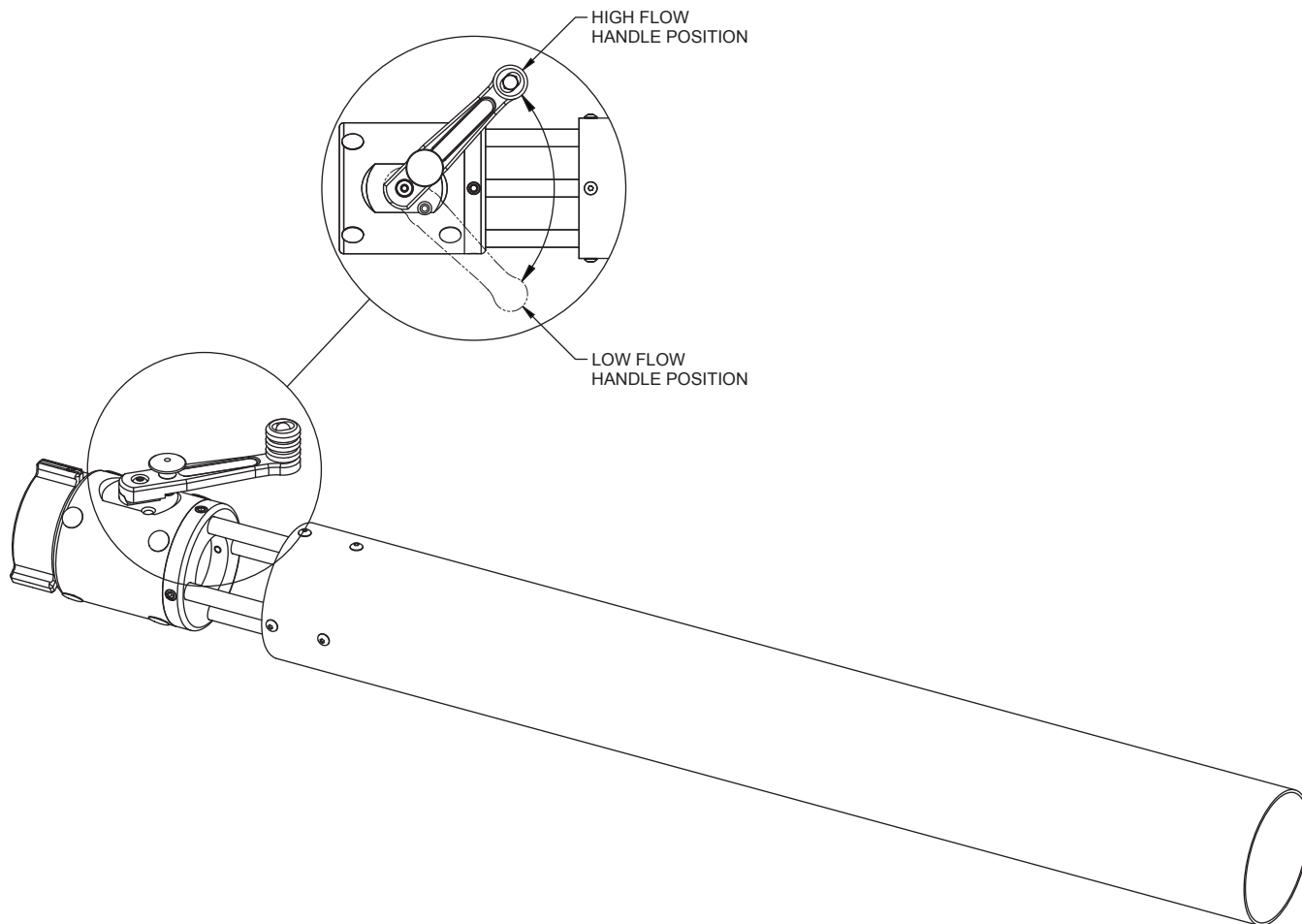

### 7.0 USE WITH SALT WATER

Use with salt water is permissible provide the nozzle is thoroughly cleaned with fresh water after each use. The service life of the nozzle may be shortened due to the effects of corrosion and is not covered under warranty.

For saltwater compatibility with foam, refer to the foam supplier's technical data.

## 8.0 Basic Guide To Foam Selection and Use

Refer to instructions and guidelines from foam manufacturer and the fire service for specific uses and application techniques.

<b>SOLID FUEL - CLASS A</b>	
Solid fuel with wettable cellular fibers that leave ash behind when burned. Examples: wood, paper, straw, brush, etc.	
<b>CLASS A</b>	
Recommended using class A foam that meets USDA Forest Service "Interim Requirements for Foam for Wildland Fires, Aircraft or Ground Application" or NFPA 298 Standard on "Foam Chemicals for Wildland Fire Control."	
<b>INVOLVED STRUCTURES</b>	<b>WILDLAND &amp; EXPOSURE PROTECTION</b>
Application rates in gpm/ft <sup>2</sup> 0.33 for fully involved	Apply as needed for penetration, isolation, cooling, and smothering
<p>Apply using high flow setting for:</p> <ul style="list-style-type: none"> <li>- soaking and penetration of fuel</li> <li>- greater stream reach</li> </ul> <p>Apply using low flow setting for:</p> <ul style="list-style-type: none"> <li>- greater coverage</li> <li>- longer lasting</li> <li>- insulating</li> </ul>	

<b>LIQUID FUEL - CLASS B</b>			
<b>HYDROCARBONS</b>		<b>POLAR SOLVENTS</b>	
Fuels that are mostly refined from crude oil or vegetable matter. Will not mix with water.		A flammable liquid that mixes with water. Examples are alcohols, amines, ethers, esters, aldehydes, and ketones. In firefighting, any flammable liquid which destroys regular foam is generally referred to as a polar solvent.	
AFFF (Aqueous Film Forming Foam) FFFP (Film Forming FluoroProtein Foam) AR-AFFF (Alcohol Resistant AFFF Foam) PROTEIN FLUOROPROTEIN		AR-AFFF (Alcohol Resistant Foam)	
<b>IGNITED</b>	<b>UNIGNITED</b>	<b>IGNITED</b>	<b>UNIGNITED</b>
Application rates in gpm/ft <sup>2</sup> : AFFF & FFFP: 0.10 Protein & Fluoroprotein: 0.16 Reapply as needed.	May apply at less than rates for ignited. Be capable of increasing to ignited rates if needed.	Application rates: Use foam manufacturer's recommendations for handheld nozzles.	
Apply using HIGH FLOW setting for extinguishment	Apply using LOW FLOW setting for vapor suppression	Apply using HIGH FLOW setting for extinguishment	Apply using LOW FLOW setting for vapor suppression

## 9.0 EXPLODED VIEW AND PARTS LIST

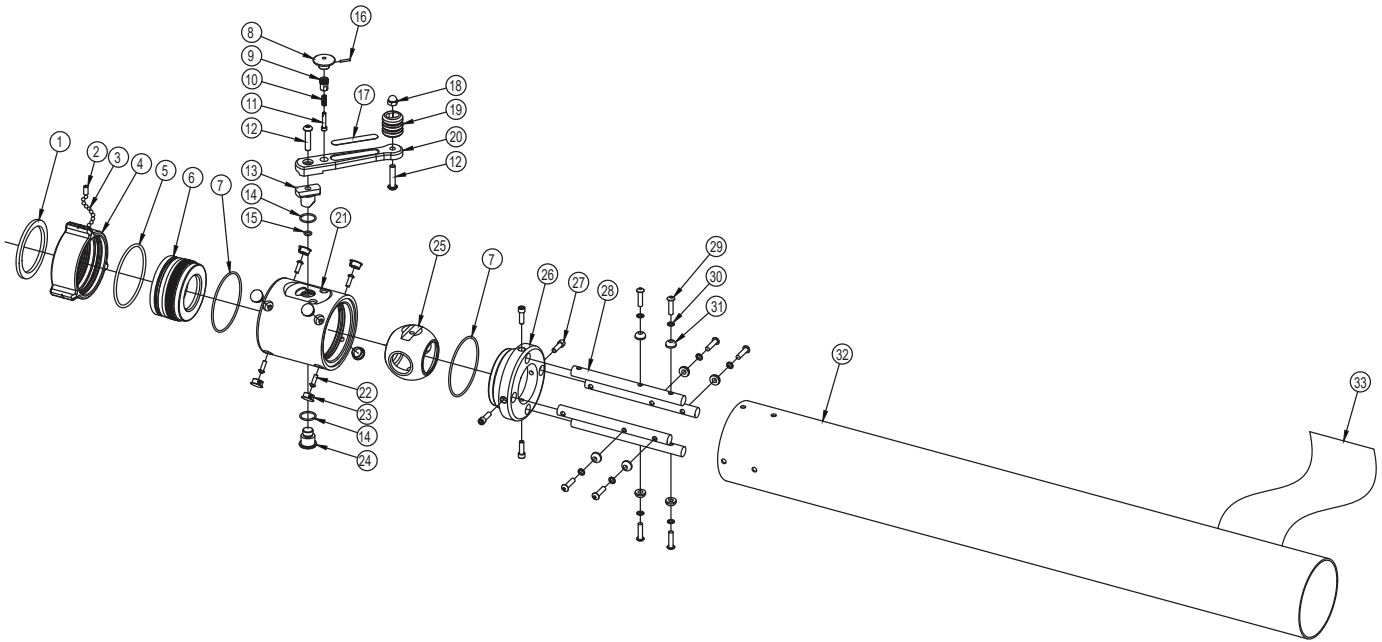

ITEM	DESCRIPTION	QTY	PART #
1	GASKET - 3.5" HOSE COUPLING	1	V3190
2	5/16-24 X 5/8 SOCKET SET SCREW	1	VT31-24SS625
3	1/4" SS BALL	54	V2125
4	COUPLING 3.5"NH ROCKERLUG	1	MS687N
5	O-RING-348	1	VO-348
6	FOAM TUBE BACK RING	1	FX570
7	O-RING-244	2	VO-244
8	PULL KNOB	1	XX341
9	PULL PIN HOUSING	1	FX575
10	PULL PIN SPRING	1	X345
11	PULL PIN	1	XX340
12	3/8-16 X 1-3/4 BUTTON HEAD SCREW	2	VT37-16BH1.7
13	TRUNNION	1	FX550
14	O-RING-120	2	VO-120
15	O-RING-012	1	VO-012
16	1/8 X 3/4 HDP SPIROL PIN	1	VP125X750H

ITEM	DESCRIPTION	QTY	PART #
17	FOAM TUBE HANDLE LABEL	1	FX585
18	3/8-16 ACORN NUT	1	VT37-16AC
19	SINGLE HANDLE TOP	1	XXL625
20	HANDLE	1	FX535
21	FOAM TUBE NOZZLE BODY	1	FX530
22	1/4-28 X 3/4 BUTTON HEAD SCREW	4	VT25-28BH750
23	DOMEPLUG	8	VM4122
24	LOWER TRUNNION	1	FX545
25	SELECTOR BALL	1	FX560
26	FRONT RING FOAM TUBE NOZZLE	1	FX525
27	5/16-18 X 1 SOCKET HEAD SCREW	4	VT31-18SH1.0
28	STANCHION	4	FX520
29	5/16-18 X 1-1/4 BUTTON HEAD SCREW	8	VT31-18BH1.2
30	WASHER	8	VW500X325-48
31	SPACER	8	FX510
32	EXPANSION TUBE	1	FX505
33	FOAM TUBE BARREL LABEL	1	FX580

## 10.0 WARRANTY

Task Force Tips LLC, 3701 Innovation Way, Valparaiso, Indiana 46383-9327 USA (“TFT”) warrants to the original purchaser of its Foam Attachment (“equipment”), and to anyone to whom it is transferred, that the equipment shall be free from defects in material and workmanship during the five (5) year period from the date of purchase.

TFT’s obligation under this warranty is specifically limited to replacing or repairing the equipment (or its parts) which are shown by TFT’s examination to be in a defective condition attributable to TFT. To qualify for this limited warranty, the claimant must return the equipment to TFT, at 3701 Innovation Way, Valparaiso, Indiana 46383-9327 USA, within a reasonable time after discovery of the defect. TFT will examine the equipment. If TFT determines that there is a defect attributable to it, it will correct the problem within a reasonable time. If the equipment is covered by this limited warranty, TFT will assume the expenses of repair.

If any defect attributable to TFT under this limited warranty cannot be reasonably cured by repair or replacement, TFT may elect to refund the purchase price of the equipment, less reasonable depreciation, in complete discharge of its obligations under this limited warranty. If TFT makes this election, claimant shall return the equipment to TFT free and clear of any liens and encumbrances.

This is a limited warranty. The original purchaser of the equipment, any person to whom it is transferred, and any person who is an intended or unintended beneficiary of the equipment, shall not be entitled to recover from TFT any consequential or incidental damages for injury to person and/or property resulting from any defective equipment manufactured or assembled by TFT. It is agreed and understood that the price stated for the equipment is in part consideration for limiting TFT’s liability. Some states do not allow the exclusion or limitation of incidental or consequential damages, so the above may not apply to you.

TFT shall have no obligation under this limited warranty if the equipment is, or has been, misused or neglected (including failure to provide reasonable maintenance) or if there have been accidents to the equipment or if it has been repaired or altered by someone else.

**THIS IS A LIMITED EXPRESS WARRANTY ONLY. TFT EXPRESSLY DISCLAIMS WITH RESPECT TO THE EQUIPMENT ALL IMPLIED WARRANTIES OF MERCHANTABILITY AND ALL IMPLIED WARRANTIES OF FITNESS FOR A PARTICULAR PURPOSE. THERE IS NO WARRANTY OF ANY NATURE MADE BY TFT BEYOND THAT STATED IN THE DOCUMENT.**

This limited warranty gives you specific legal rights, and you may also have other rights which vary from state to state.

## 11.0 MAINTENANCE

TFT products are designed and manufactured to be damage resistant and require minimal maintenance. However, as the primary firefighting tool upon which your life depends, it should be treated accordingly. To help prevent mechanical damage, do not drop or throw equipment.

### 11.1 FIELD LUBRICATION

All Task Force Tips’ nozzles are factory lubricated with high quality silicone grease. This lubricant has excellent wash out resistance and long term performance in firefighting nozzles. If your department has unusually hard or sandy water, the moving parts of the nozzle may be affected. Foam agents and water additives contain soaps and chemicals that may break down the factory lubrication.

The moving parts of the nozzle should be checked on a regular basis for smooth and free operation, and for signs of damage. **IF THE NOZZLE IS OPERATING CORRECTLY, THEN NO ADDITIONAL LUBRICANT IS NEEDED.** Any nozzle that is not operating correctly should be immediately removed from service.

The field use of Break Free CLP (spray or liquid) lubricant will help to restore the smooth and free operation of the nozzle. However, these lubricants do not have the washout resistance and long-term performance of the silicone grease. Therefore, re-application of Break Free CLP will be needed on a regular basis. The nozzle can be returned to the factory at any time for a complete checkup and re-lubrication with silicone grease.



**Aerosol lubricants contain solvents that can swell O-Rings if applied in excess. The swelling can inhibit smooth operation of the moving parts. When used in moderation, as directed, the solvents quickly evaporate without adversely swelling the O-Rings.**

### 11.2 SERVICE TESTING

In accordance with NFPA 1962, nozzles must be tested a minimum of annually. Nozzles failing any part of this test must be removed from service, repaired and retested upon completion of the repair.

#### 11.2.1 FLOW TESTING

Flow testing must be conducted in the following manner.

1. The nozzle shall be mounted so that the flow rate and pressure through the nozzle and the pressure at the inlet can be accurately measured.
2. With the shut off fully open, the inlet pressure shall be adjusted to the rated pressure  $\pm 2$  percent.
3. Evaluate the flow of nozzles as defined by NFPA 1964 in the following manner:  
Constant and Select Gallonage Spray Nozzles  
The flow rate shall be no less than the rated flow at the rated pressure and no more than 10 percent over the rated flow at the rated pressure when tested at each predetermined flow selection.
4. The valve or shut off and pattern controls shall be operated through their full range of motion at 100 psi (6.9 bar or 690 kPa) with no signs of leaking, binding or other problems.

## 11.2.1 RECORDS

A record of testing and repairs must be maintained from the time the nozzle is purchased until it is discarded. Each TFT nozzle is engraved with a unique serial number which, if so desired, can be used to identify nozzle for documentation purposes.

The following information, if applicable, must be included on the test record for each nozzle:

1. Assigned identification number
2. Manufacturer
3. Product or model designation
4. Vendor
5. Warranty
6. Hose connection size
7. Maximum operating pressure
8. Flow rate or range
9. Date received and date put in service
10. Date of each service test and service test results
11. Damage and repairs, including who made the repairs and the cost of repair parts
12. Reason removed from service

NFPA 1962: Standard for the care, use, inspection, service testing, and replacement of fire hose, couplings, nozzles and fire hose appliances. Quincy, MA: National Fire Protection Agency.

## 11.3 REPAIR

Factory service is available with repair time seldom exceeding one day in our facility. Factory serviced nozzles are repaired by experienced technicians, wet tested to original specifications, and promptly returned. Repair charges for non-warranty items are minimal. Any returns should include a note as to the nature of the problem and whom to reach in case of questions.

Repair parts and service procedures are available for those wishing to perform their own repairs. Task Force Tips assumes no liability for damage to equipment or injury to personnel that is a result of user service. Contact the factory or visit the web site at [tft.com](http://tft.com) for parts lists, exploded views, test procedures and troubleshooting guides. All replacement parts must be obtained from the manufacturer to assure proper operation of the product, and to maintain approval of the device.

Performance tests shall be conducted on the nozzle after a repair, or anytime a problem is reported to verify operation in accordance with TFT test procedures. Consult factory for the procedure that corresponds to the model and serial number of the nozzle. Any equipment which fails the related test criteria should be removed from service immediately. Troubleshooting guides are available with each test procedure or equipment can be returned to the factory for service and testing

## 12.0 INSPECTION CHECKLIST

**BEFORE EACH USE, appliances must be inspected to this checklist:**

- There is no obvious damage such as missing, broken or loose parts, dents, cracks, corrosion, or other defects that could impair operation
- The waterway is clear of obstructions.
- Nozzle are securely attached
- All swiveling elements rotate freely
- Nozzle is pointed in a safe direction

**BEFORE BEING PLACED BACK IN SERVICE, appliances must be inspected to this list:**

- The waterway is clear of obstructions.
- There is no damage to any type connection.
- All locks and hold-down devices work properly.
- There is no damage to the appliance that could impair safe operation (e.g. dents, cracks, corrosion or other defects)
- All swiveling connections rotate freely.
- There are no missing parts or components.



**Any nozzle failing any part of the checklist is unsafe for use and must have the problem corrected before use or being placed back into service. Operating a nozzle that has failed the checklist is a misuse of this equipment.**