

## LDH GATED WYE

### INSTRUCTION FOR INSTALLATION, OPERATION, AND MAINTENANCE

#### **⚠ DANGER**

Understand manual before use. Operation of this device without understanding the manual and receiving proper training is a misuse of this equipment. Obtain safety information at [tft.com/](http://tft.com/) serial-number.

This equipment is intended for use by trained and qualified emergency services personnel for firefighting. All personnel using this equipment shall have completed a course of education approved by the Authority Having Jurisdiction (AHJ).

This instruction manual is intended to familiarize firefighters and maintenance personnel with the operation, servicing, and safety procedures associated with this product. This manual should be kept available to all operating and maintenance personnel.

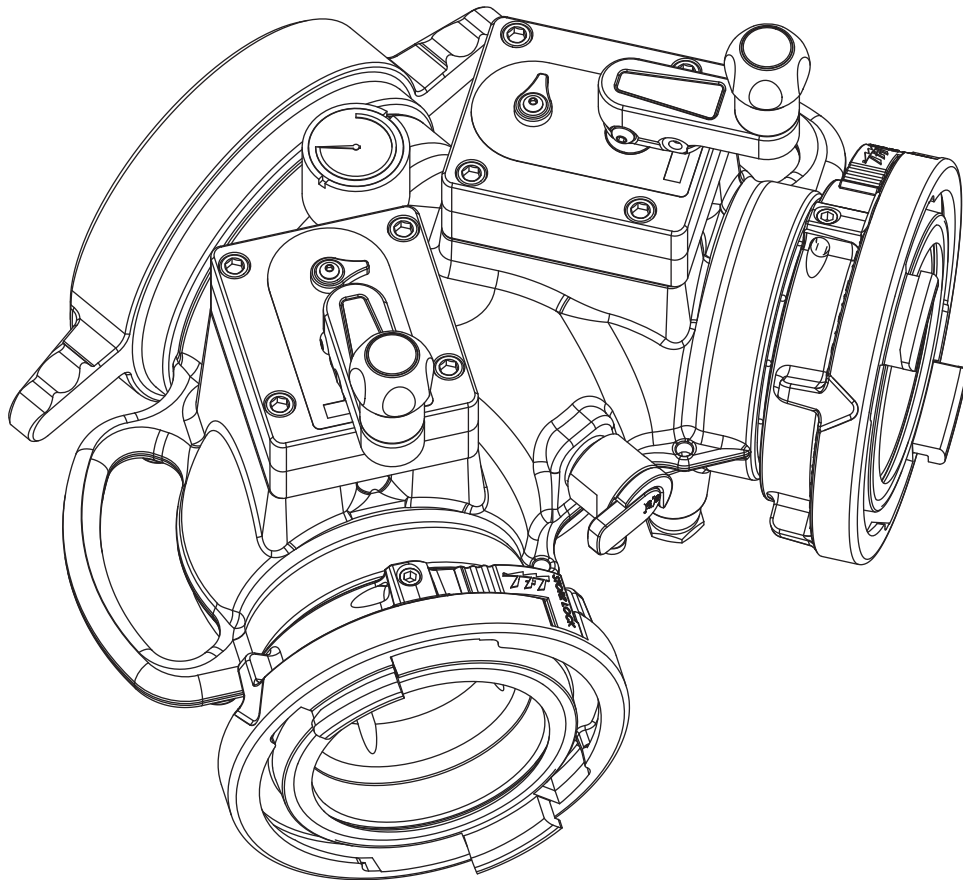

# DANGER

## PERSONAL RESPONSIBILITY CODE

The member companies of FEMSA that provide emergency response equipment and services want responders to know and understand the following:

1. Firefighting and Emergency Response are inherently dangerous activities requiring proper training in their hazards and the use of extreme caution at all times.
2. **IT IS YOUR RESPONSIBILITY** to read and understand any user's instructions, including purpose and limitations, provided with any piece of equipment you may be called on to use.
3. **IT IS YOUR RESPONSIBILITY** to know that you have been properly trained in Firefighting and/or Emergency Response and in the use, precautions, and care of any equipment you may be called upon to use.
4. **IT IS YOUR RESPONSIBILITY** to be in proper physical condition and to maintain the personal skill level required to operate any equipment you may be called upon to use.
5. **IT IS YOUR RESPONSIBILITY** to know that your equipment is in operable condition and has been maintained in accordance with the manufacturer's instructions.
6. Failure to follow these guidelines may result in death, burns or other severe injury.

Fire and Emergency Manufacturers and Service Association, Inc.  
PO Box 147, Lynnfield, MA 01940 • [www.FEMSA.org](http://www.FEMSA.org)

© 2020 FEMSA. All Rights Reserved.

**FEMSA**

### SUPPORTING MATERIALS

The following document contains supporting safety and operating information pertaining to the equipment described in this manual.

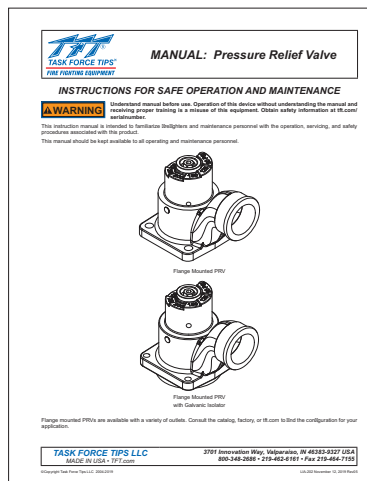

LIA-202  
Pressure Relief Valve Manual

## TABLE OF CONTENTS

- 1.0 MEANING OF SAFETY SIGNAL WORDS
- 2.0 SAFETY
- 3.0 GENERAL INFORMATION
  - 3.1 SPECIFICATIONS
  - 3.2 VARIOUS MODELS AND TERMS
  - 3.3 CORROSION
  - 3.4 USE WITH SALT WATER
- 4.0 INSTALLATION
  - 4.1 MOUNTING THE APPLIANCE
  - 4.2 CHANGING THE CRANK HANDLE OFFSET
  - 4.3 STORZ GASKET REQUEST
- 5.0 USE
  - 5.1 VALVE POSITION INDICATOR
  - 5.2 AIR VENT AND WATER DRAIN
  - 5.3 PRESSURE RELIEF VALVE (PRV)
    - 5.3.1 RELIEF VALVE PRESSURE SETTING
  - 5.4 VALVE PRESSURE LOSS
  - 5.5 SUCTION SCREEN
- 6.0 WARRANTY
- 7.0 MAINTENANCE
  - 7.0.1 TROUBLESHOOTING
  - 7.1 SERVICE TESTING
  - 7.2 REPAIR
- 8.0 EXPLODED VIEW AND PARTS LISTS
- 9.0 OPERATION AND INSPECTION CHECKLIST

### 1.0 MEANING OF SAFETY SIGNAL WORDS

A safety related message is identified by a safety alert symbol and a signal word to indicate the level of risk involved with a particular hazard. Per ANSI Z535.6, the definitions of the four signal words are as follows:



**DANGER** indicates a hazardous situation which, if not avoided, will result in death or serious injury.



**WARNING** indicates a hazardous situation which, if not avoided, could result in death or serious injury.



**CAUTION** indicates a potentially hazardous situation which, if not avoided, could result in minor or moderate injury.



**NOTICE** is used to address practices not related to physical injury.

## 2.0 SAFETY

### **⚠ DANGER**

An inadequate supply of pressure and/or flow will cause an ineffective stream and can result in injury or death. Choose operating conditions to deliver adequate fire suppression.

### **⚠ WARNING**

This equipment is intended for use by trained personnel for firefighting. Use of this equipment for other purposes may involve hazards not addressed by this manual. Seek appropriate guidance and training to reduce risk of injury.

### **⚠ WARNING**

Equipment may be damaged if frozen while containing significant amounts of water. Such damage may be difficult to detect visually. Subsequent pressurization can lead to injury or death. Any time the equipment is subject to possible damage due to freezing, it must be tested and approved for use by qualified personnel before being considered safe for use.

### **⚠ WARNING**

Sudden changes in valve position can cause pressure spikes (water hammer) and could lead to hose or pipe failure or an out of control monitor. Open and close the valve slowly to avoid water hammer.

### **⚠ WARNING**

Interrupting flow to the device could cause injury or death. Avoid situations that may interrupt flow to the device such as: hose line kinks, traffic running over hose, and automatic doors or devices that can pinch the hose.

### **NOTICE**

To prevent mechanical damage, do not drop or throw equipment.

## 3.0 GENERAL INFORMATION

The LDH Gated Wye is a lightweight, low friction-loss valve that can be used in many water distribution applications. Dual robust valve mechanisms from the TFT Ball Intake Valve are streamlined to a large waterway for the ultimate in versatility. Valve seats are field replaceable. Devices include a 300PSI pressure gage and quarter turn air vent and drain valve. Integrated carrying handles make for easy deployment. A polymer bearing ring prevents galvanic corrosion on LDH couplings.

### 3.1 SPECIFICATIONS

MODEL	STANDARD	METRIC
Dual LDH Waterway Size (at valve seat)	3.65"	93 mm
LDH Valve Meets NFPA Slow Close Requirement		
Maximum Operating Pressure	300 psi	20 bar
Hydrostatic Proof Test Pressure	900 psi	62 bar
Operating Temperature Range of Fluid	33° to 120°F	0° to 50°C
Storage Temperature Range*	-40° to 150°F	-40° to 65°C
Materials Used	Aluminum 6000 series hard anodized MIL8625 class 3 type 2, stainless steel 300 series	

\* For temperatures below 32° (0°C), valves must be drained after use to avoid damage.

Table 3.1

### 3.2 VARIOUS MODELS AND TERMS

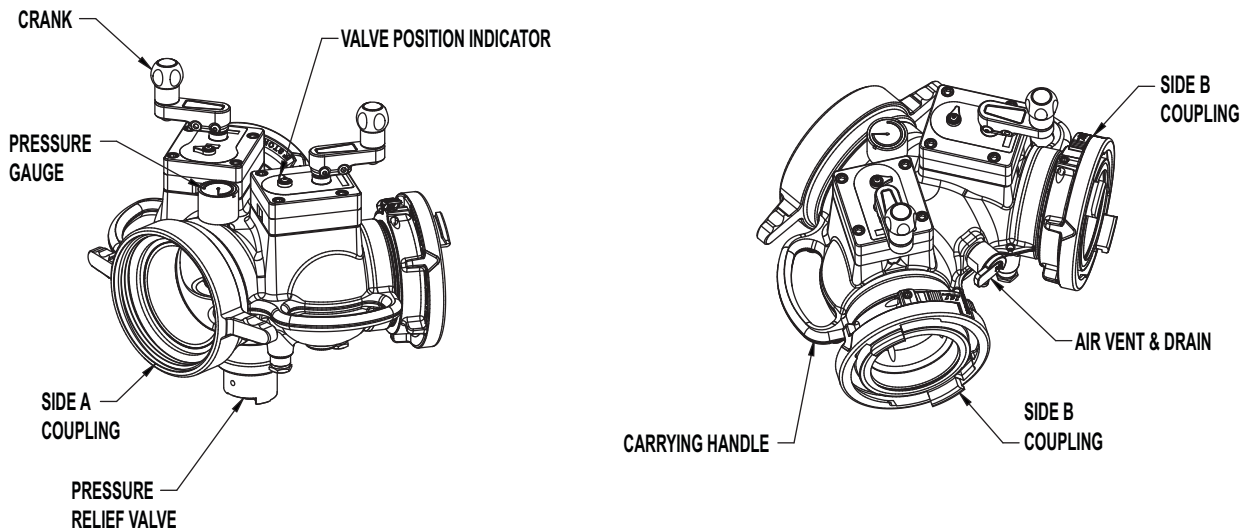

Figure 3.2

### 3.3 CORROSION

Aluminum parts are hard anodized. All castings are then powder coated inside and out to help prevent corrosion. Most hose couplings are attached using polymer bearing rings which provide electrical insulation to help prevent galvanic corrosion. The effects of corrosion can be minimized by good maintenance practice.

### 3.4 USE WITH SALT WATER

Use with salt water is permissible provided the equipment is thoroughly cleaned with fresh water after each use. The service life of the equipment may be shortened due to the effects of corrosion, and is not covered under warranty.

## 4.0 INSTALLATION

### 4.1 MOUNTING THE APPLIANCE

Make connections to fire hose or fittings on each side of the valved appliance.

**CAUTION** Mismatched or damaged waterway connections may cause equipment to leak or uncouple under pressure. Failure could result in injury. Equipment must be mated to matched connections.

**CAUTION** Dissimilar metals coupled together can cause galvanic corrosion that can result in the inability to uncouple the connection, or complete loss of engagement over time. Failure could cause injury. Per NFPA 1962, if dissimilar metals are left coupled together, an anti-corrosive lubricant should be applied to the connection and the coupling should be disconnected and inspected at least quarterly.

### 4.2 CHANGING THE CRANK HANDLE OFFSET

When equipped with a crank handle, two offset positions are available to adjust the swing radius of the crank and knob. The longer offset position offers reduced effort to operate the valve. The shorter offset is available to avoid interference with other equipment.

To change the offset:

1. Remove the two 1/4-20 x 1/2" button head cap screws from the crank.
2. Place the crank in the desired position.
3. Replace the screws.

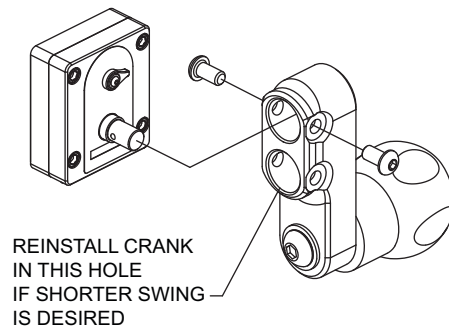

Figure 4.2

### 4.3 STORZ GASKET REQUEST

If your application of this product requires drafting, you may need a suction gasket. Please call 1-800 348-2686 to receive a free suction gasket by mail.

Part Numbers: 4" Storz - item #A4216, 5" Storz - item #A4221, 6" Storz - item #A4226

## 5.0 USE

### 5.1 VALVE POSITION INDICATOR

To open the valve turn the crank until the valve position indicator says "OPEN". To close the valve turn the valve crank the opposite way until the valve position indicator says "CLOSED".

### 5.2 AIR VENT AND WATER DRAIN

**CAUTION** Loss of prime can interrupt water flow and cause injury or death. Always bleed out air with air vent/drain to prevent possible loss of prime.

This device may be equipped with an air vent/drain which will allow the air to escape from the valve when the hose is charged. The air vent/drain is opened by turning the knob counter-clockwise and closed by turning it clockwise.

To drain the water out of the valve after use, open the air vent/drain. A 1/2" Diameter tube may be used to direct the drained water away from the device.

### 5.3 PRESSURE RELIEF VALVE (PRV)

**WARNING** The Pressure Relief Valve is disabled in the OFF position and offers no system protection against over-pressurization. Avoid water hammer or other pressure spikes during pump tests. Ensure PRV is returned to its normal pressure setting following pump testing.

LDH valved appliances may be equipped with a pressure relief valve that can be set to any pressure between 50 and 200 psi. Its function is to protect the pump and supply hose from excess pressure.

### 5.3.1 RELIEF VALVE PRESSURE SETTING

To set the relief valve pressure turn the adjusting screw on the relief valve housing until the surface of the screw is even with the desired pressure. A 9/16" (14 mm) socket or a 1/4" hex key may be used to turn the adjusting screw. The Pressure relief valve should not be disabled (IE: capped, plugged, or set to the OFF position) for normal service conditions. Disabling the relief valve may result in system damage or hose rupture if the system exceeds operating limits. The pressure relief valve meets the requirements of NFPA 1900.

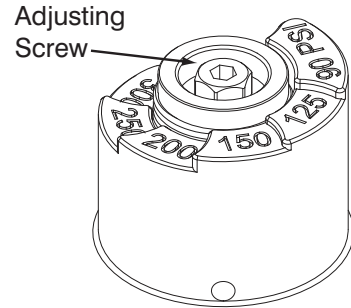

Figure 5.3.1

### 5.4 VALVE PRESSURE LOSS

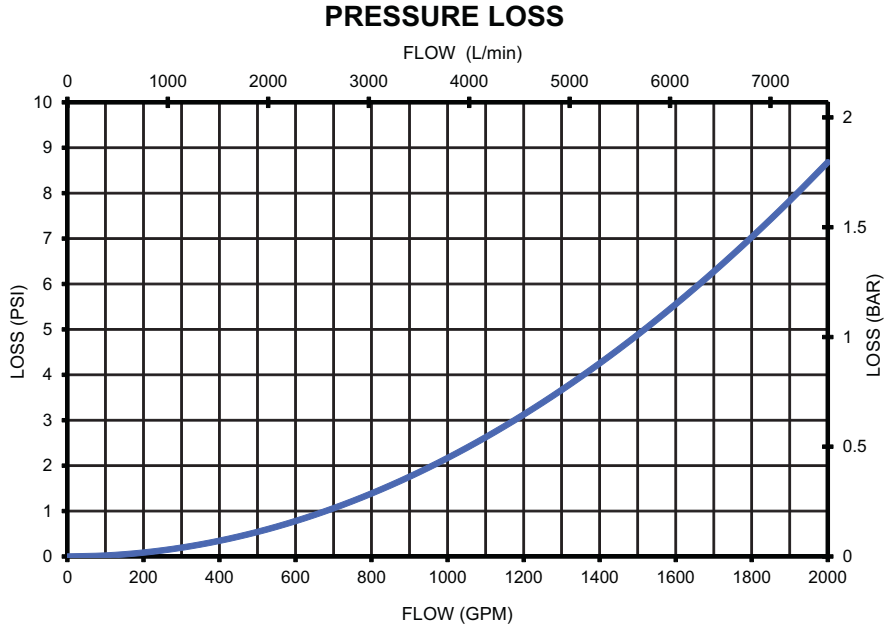

Figure 5.4

### 5.5 SUCTION SCREEN

This device may be equipped with a suction screen to catch debris larger than 3/8" diameter in the waterway. See chart below to determine additional loss caused by screen. To add or replace a suction screen, order TFT Part #A1410-KIT for 4.5" waterway couplings or A1411-KIT for 5" waterway couplings.

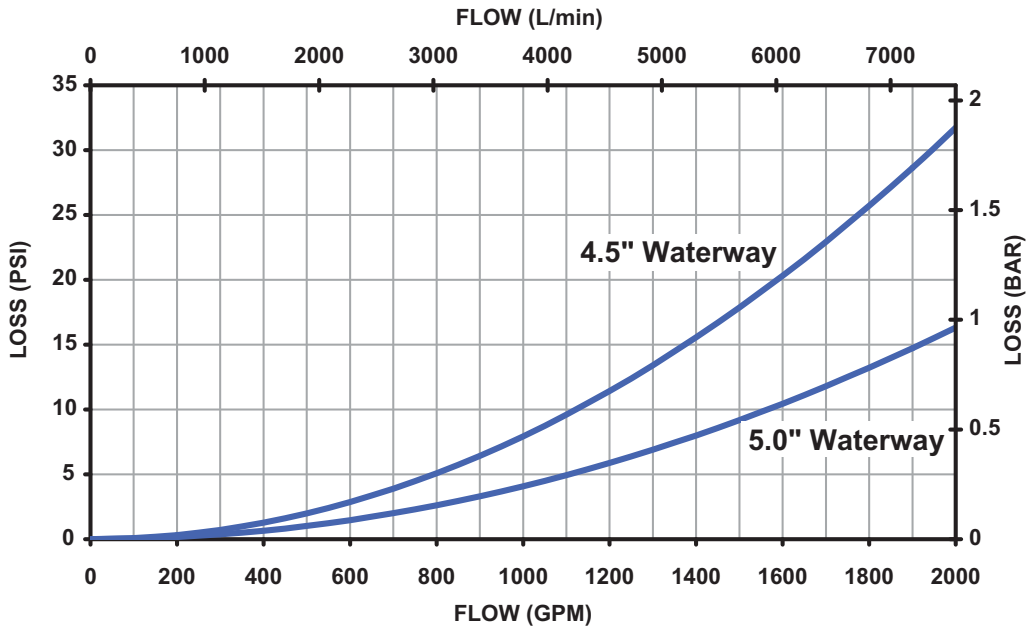

Figure 5.5

## 6.0 WARRANTY

Task Force Tips LLC, 3701 Innovation Way, Valparaiso, Indiana 46383-9327 USA (“TFT”) warrants to the original purchaser of its products (“equipment”), and to anyone to whom it is transferred, that the equipment shall be free from defects in material and workmanship during the five (5) year period from the date of purchase for mechanical components, and the two (2) year period from the date of purchase for electrical components. TFT’s obligation under this warranty is specifically limited to replacing or repairing the equipment (or its parts) which are shown by TFT’s examination to be in a defective condition attributable to TFT. To qualify for this limited warranty, the claimant must return the equipment to TFT, at 3701 Innovation Way, Valparaiso, Indiana 46383-9327 USA, within a reasonable time after discovery of the defect. TFT will examine the equipment. If TFT determines that there is a defect attributable to it, TFT will correct the problem within a reasonable time. If the equipment is covered by this limited warranty, TFT will assume the expenses of repair.

If any defect attributable to TFT under this limited warranty cannot be reasonably cured by repair or replacement, TFT may elect to refund the purchase price of the equipment, less reasonable depreciation, in complete discharge of its obligations under this limited warranty. If TFT makes this election, claimant shall return the equipment to TFT free and clear of any liens and encumbrances.

This is a limited warranty. The original purchaser of the equipment, any person to whom it is transferred, and any person who is an intended or unintended beneficiary of the equipment, shall not be entitled to recover from TFT any consequential or incidental damages for injury to person and/or property resulting from any defective equipment manufactured or assembled by TFT.

It is agreed and understood that the price stated for the equipment is in part consideration for limiting TFT’s liability. Some states do not allow the exclusion or limitation of incidental or consequential damages, so the above may not apply to you.

TFT shall have no obligation under this limited warranty if the equipment is, or has been, misused or neglected (including failure to provide reasonable maintenance) or if there have been accidents to the equipment or if it has been repaired or altered by someone else.

**THIS IS A LIMITED EXPRESS WARRANTY ONLY. TFT EXPRESSLY DISCLAIMS WITH RESPECT TO THE EQUIPMENT ALL IMPLIED WARRANTIES OF MERCHANTABILITY AND ALL IMPLIED WARRANTIES OF FITNESS FOR A PARTICULAR PURPOSE. THERE IS NO WARRANTY OF ANY NATURE MADE BY TFT BEYOND THAT STATED IN THIS DOCUMENT.**

This limited warranty gives you specific legal rights, and you may also have other rights which vary from state to state.

## 7.0 MAINTENANCE

TFT products are designed and manufactured to be damage resistant and require minimal maintenance. However, as the primary firefighting tool upon which your life depends, it should be treated accordingly. The unit should be kept clean and free of dirt by rinsing with water after each use. Any inoperable or damaged parts should be repaired or replaced before placing the unit in service. To help prevent mechanical damage, do not drop or throw equipment.

In applications where appliances are left continuously connected to the apparatus or other devices or are used where water is trapped inside the appliance, the appliance must be flushed with fresh water following each use and inspected for damage.

This appliance should be disconnected, cleaned and visually inspected inside and out at least quarterly, or as water quality and use may require. Moving parts such as handles, valve ball and couplings should be checked for smooth and free operation. Seals shall be greased as needed with Silicone based grease such as Molykote 112. Any scrapes that expose bare aluminum should be cleaned and touched up with enamel paint such as Rust-Oleum. Replace any missing or damaged parts before returning to service.

Any equipment taken out of service due to failure should be returned to the factory for repair or replacement. If you have any questions regarding the testing or maintenance of your valve, please call Task Force Tips at 800-348-2686.

### 7.0.1 TROUBLESHOOTING

<b>SYMPTOM</b>	<b>POSSIBLE CAUSE</b>	<b>REMEDY</b>
Leaks	Debris or damage in seal area	Clean out debris and/or replace damaged parts

Table 7.0.1

## 7.1 SERVICE TESTING

In accordance with NFPA 1962, equipment must be tested a minimum of annually. Units failing any part of this test must be removed from service, repaired and retested upon completion of the repair.

## 7.2 REPAIR

Factory service is available. Factory serviced equipment is repaired by experienced technicians, wet tested to original specifications, and promptly returned. Call TFT service department at 1-800-348-2686 to troubleshoot and, if needed, directions for return. A return for service form can also be obtained at [tft.com/Support/Returning-an-Item-for-Service](http://tft.com/Support/Returning-an-Item-for-Service).

Repair parts and service procedures are available for those wishing to perform their own repairs. Task Force Tips assumes no liability for damage to equipment or injury to personnel that is a result of user service. Contact the factory or visit the web site at [tft.com](http://tft.com) for parts lists, exploded views, test procedures and troubleshooting guides.

Performance tests shall be conducted on the equipment after a repair, or anytime a problem is reported to verify operation in accordance with TFT test procedures. Consult factory for the procedure that corresponds to the model and serial number of the equipment. Any equipment which fails the related test criteria should be removed from service immediately. Troubleshooting guides are available with each test procedure or equipment can be returned to the factory for service and testing.

### **WARNING**

It is the responsibility of service technicians to ensure the use of appropriate protective clothing and equipment. The chosen protective clothing and equipment must provide protection from potential hazards users may encounter while servicing equipment. Requirements for protective clothing and equipment are determined by the Authority Having Jurisdiction (AHJ).

### **CAUTION**

Any alterations to the product or its markings could diminish safety and constitutes a misuse of this product.

### **NOTICE**

All replacement parts must be obtained from the manufacturer to assure proper performance and operation of the device.

## 8.0 EXPLODED VIEW AND PARTS LISTS

Exploded views and part lists are available at [tft.com/serial-number](http://tft.com/serial-number).

## 9.0 OPERATION AND INSPECTION CHECKLIST

**BEFORE EACH USE**, equipment must be inspected to this checklist:

1. All valves open and close fully and smoothly.
2. Waterway is clear of obstructions.
3. There is no damage to any thread or other connection.
4. All locks and hold-down devices work properly.
5. The pressure setting on the relief valve (if so equipped) is set correctly.
6. Gaskets are in good condition.
7. There is no obvious damage such as missing, broken or loose parts.
8. There is no damage to the appliance (e.g. dents, cracks, corrosion, or other defects that could impair operation).
9. All swiveling elements rotate freely.
10. There is no corrosion on any surface.
11. There are no missing, worn out or broken lugs on couplings.
12. Hose is securely attached.

**BEFORE BEING PLACED BACK IN SERVICE**, equipment must be inspected to this list:

1. All valves open and close smoothly and fully.
2. The waterway is clear of obstructions.
3. There is no damage to any thread or other type connection.
4. The pressure setting on the relief valve (if so equipped) is set correctly.
5. All locks and hold-down devices work properly.
6. Internal gaskets are in good condition
7. There is no damage to the appliance (e.g., dents, cracks, corrosion, or other defects that could impair operation).
8. All swiveling connections rotate freely.
9. There are no missing parts or components.
10. The marking for maximum operating pressure is visible.
11. There are no missing, broken, or worn lugs on couplings.

### **WARNING**

Equipment failing any part of the checklist is unsafe for use and must have the problem corrected before use or being placed back into service. Operating equipment that has failed the checklist is a misuse of this equipment.