

OASIS HYDRANT ASSIST VALVE

INSTRUCTION FOR INSTALLATION, OPERATION, AND MAINTENANCE

⚠ DANGER

Understand manual before use. Operation of this device without understanding the manual and receiving proper training is a misuse of this equipment. Obtain safety information at tft.com/ serial-number.

This equipment is intended for use by trained and qualified emergency services personnel for firefighting. All personnel using this equipment shall have completed a course of education approved by the Authority Having Jurisdiction (AHJ).

This instruction manual is intended to familiarize firefighters and maintenance personnel with the operation, servicing, and safety procedures associated with this product. This manual should be kept available to all operating and maintenance personnel.

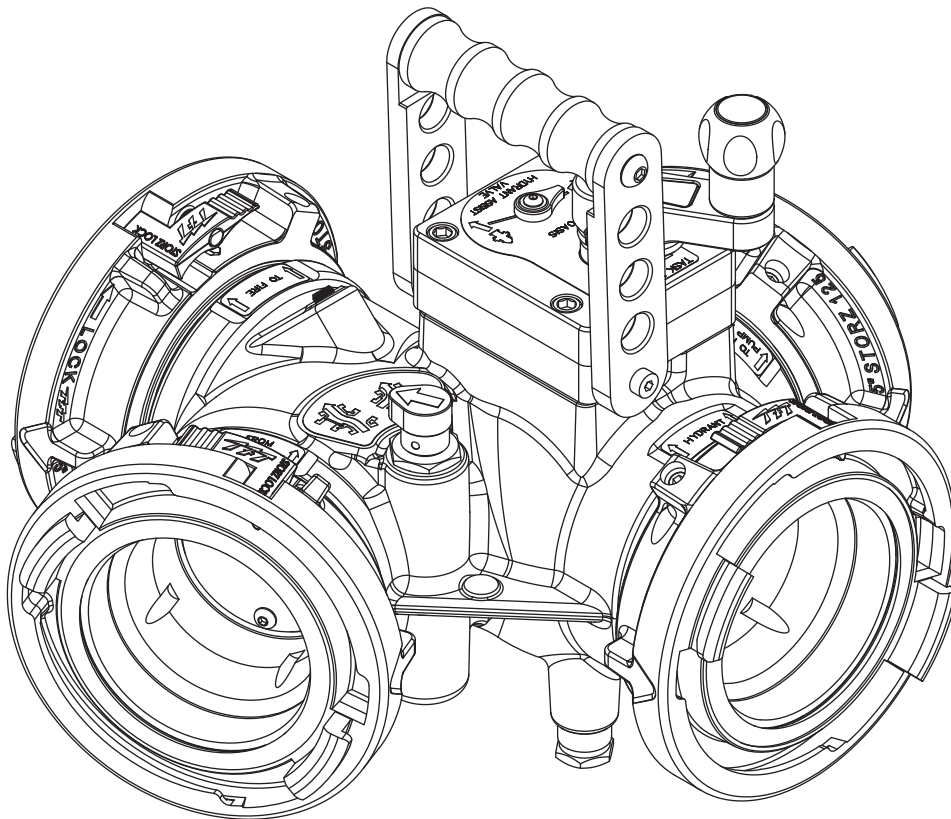

DANGER

PERSONAL RESPONSIBILITY CODE

The member companies of FEMSA that provide emergency response equipment and services want responders to know and understand the following:

1. Firefighting and Emergency Response are inherently dangerous activities requiring proper training in their hazards and the use of extreme caution at all times.
2. **IT IS YOUR RESPONSIBILITY** to read and understand any user's instructions, including purpose and limitations, provided with any piece of equipment you may be called on to use.
3. **IT IS YOUR RESPONSIBILITY** to know that you have been properly trained in Firefighting and/or Emergency Response and in the use, precautions, and care of any equipment you may be called upon to use.
4. **IT IS YOUR RESPONSIBILITY** to be in proper physical condition and to maintain the personal skill level required to operate any equipment you may be called upon to use.
5. **IT IS YOUR RESPONSIBILITY** to know that your equipment is in operable condition and has been maintained in accordance with the manufacturer's instructions.
6. Failure to follow these guidelines may result in death, burns or other severe injury.

Fire and Emergency Manufacturers and Service Association, Inc.
PO Box 147, Lynnfield, MA 01940 • www.FEMSA.org

© 2020 FEMSA. All Rights Reserved.







TABLE OF CONTENTS







- 1.0 MEANING OF SAFETY SIGNAL WORDS
- 2.0 SAFETY
- 3.0 GENERAL INFORMATION
 - 3.1 SPECIFICATIONS
 - 3.2 VARIOUS MODELS AND TERMS
 - 3.3 CORROSION
 - 3.4 USE WITH SALT WATER
- 4.0 INSTALLATION
 - 4.1 MOUNTING THE APPLIANCE
 - 4.2 CHANGING THE CRANK HANDLE OFFSET
- 5.0 USE
 - 5.1 ATTACHING TO A HYDRANT
 - 5.2 HYDRANT ASSIST OPERATION
 - 5.2.1 MODE 1 (STRAIGHT THRU VALVE)
 - 5.2.2 MODE 2 (BOOST)
 - 5.2.3 RELAY OPERATION (STRAIGHT THRU VALVE)
 - 5.2.4 RELAY OPERATIONS (BOOST)
 - 5.3 CLAPPER VALVE POSITION INDICATOR
 - 5.3.1 MODE 1 (STRAIGHT THRU VALVE)
 - 5.3.2 MODE 2 (BOOST)
 - 5.4 FLOW INCREASE FROM BOOSTING
 - 5.5 VALVE PRESSURE LOSS
- 6.0 MODIFICATION TO ALLOW SHUT OFF OF THE HYDRANT
- 7.0 WARRANTY
- 8.0 MAINTENANCE
 - 8.0.1 TROUBLESHOOTING
 - 8.1 SERVICE TESTING
 - 8.2 REPAIR
- 9.0 EXPLODED VIEW AND PARTS LISTS
- 10.0 OPERATION AND INSPECTION CHECKLIST

1.0 MEANING OF SAFETY SIGNAL WORDS

A safety related message is identified by a safety alert symbol and a signal word to indicate the level of risk involved with a particular hazard. Per ANSI Z535.6, the definitions of the four signal words are as follows:

	DANGER indicates a hazardous situation which, if not avoided, will result in death or serious injury.
	WARNING indicates a hazardous situation which, if not avoided, could result in death or serious injury.
	CAUTION indicates a potentially hazardous situation which, if not avoided, could result in minor or moderate injury.
	NOTICE is used to address practices not related to physical injury.

2.0 SAFETY

	An inadequate supply of pressure and/or flow will cause an ineffective stream and can result in injury or death. Choose operating conditions to deliver adequate fire suppression.
	This equipment is intended for use by trained personnel for firefighting. Use of this equipment for other purposes may involve hazards not addressed by this manual. Seek appropriate guidance and training to reduce risk of injury.
	Equipment may be damaged if frozen while containing significant amounts of water. Such damage may be difficult to detect visually. Subsequent pressurization can lead to injury or death. Any time the equipment is subject to possible damage due to freezing, it must be tested and approved for use by qualified personnel before being considered safe for use.
	Sudden changes in valve position can cause pressure spikes (water hammer) and could lead to hose or pipe failure or an out of control monitor. Open and close the valve slowly to avoid water hammer.
	Interrupting flow to the device could cause injury or death. Avoid situations that may interrupt flow to the device such as: hose line kinks, traffic running over hose, and automatic doors or devices that can pinch the hose.
	To prevent mechanical damage, do not drop or throw equipment.

3.0 GENERAL INFORMATION

TFT's Oasis Hydrant Assist Valve is a versatile valve that can be used as a hydrant booster, a gated wye, or for inline pumping during relay operations.

In hydrant boosting operation, the valve is first connected to the hydrant and to the intake supply line on the first pumper. Inlet and outlet supply lines on a boost pumper are then connected to the valve to draw water directly from the hydrant connection and increase pressure/flow to the first pumper.

A clapper valve with position indicator provides uninterrupted water flow to the fire when transitioning to boost mode, and in the event of boost pump failure. Valve position indicators tell the operator if the ball and clapper valves are open, closed, or somewhere in between.

Designed for use with 3.5", 4", 4.5" or 5" (89, 100, 115 or 125 mm) hose. Aluminum half ball valve provides corrosion protection. The aluminum casting is hardcoat anodized inside and out, and TFT powder coat finished on the outside.

3.1 SPECIFICATIONS

MODEL	STANDARD	METRIC
LDH Waterway Size (at valve seat)	3.65"	93 mm
LDH Valve Meets NFPA Slow Close Requirement		
Maximum Operating Pressure	250 psi	17 bar
Hydrostatic Proof Test Pressure	900 psi	62 bar
Operating Temperature Range of Fluid	33° to 120°F	0° to 50°C
Storage Temperature Range*	-40° to 150°F	-40° to 65°C
Materials Used	Aluminum 6000 series hard anodized MIL8625 class 3 type 2, stainless steel 300 series	

* For temperatures below 32° (0°C), valves must be drained after use to avoid damage.

Table 3.1

3.2 VARIOUS MODELS AND TERMS

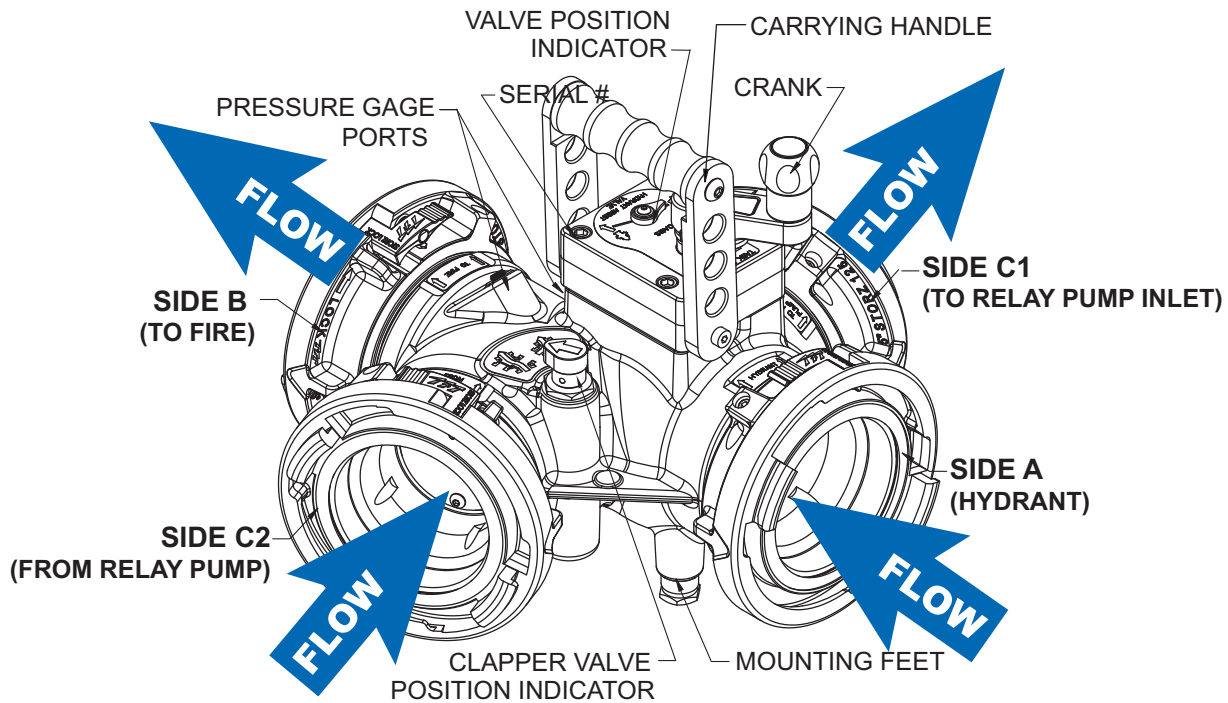

Figure 3.2

3.3 CORROSION

Aluminum parts are hard anodized. All castings are then powder coated inside and out to help prevent corrosion. Most hose couplings are attached using polymer bearing rings which provide electrical insulation to help prevent galvanic corrosion. The effects of corrosion can be minimized by good maintenance practice.

3.4 USE WITH SALT WATER

Use with salt water is permissible provided the equipment is thoroughly cleaned with fresh water after each use. The service life of the equipment may be shortened due to the effects of corrosion, and is not covered under warranty.

4.0 INSTALLATION

4.1 MOUNTING THE APPLIANCE

Make connections to fire hose or fittings on each side of the valved appliance.

CAUTION Mismatched or damaged waterway connections may cause equipment to leak or uncouple under pressure. Failure could result in injury. Equipment must be mated to matched connections.

CAUTION Dissimilar metals coupled together can cause galvanic corrosion that can result in the inability to uncouple the connection, or complete loss of engagement over time. Failure could cause injury. Per NFPA 1962, if dissimilar metals are left coupled together, an anti-corrosive lubricant should be applied to the connection and the coupling should be disconnected and inspected at least quarterly.

4.2 CHANGING THE CRANK HANDLE OFFSET

When equipped with a crank handle, two offset positions are available to adjust the swing radius of the crank and knob. The longer offset position offers reduced effort to operate the valve. The shorter offset is available to avoid interference with other equipment.

To change the offset:

1. Remove the two 1/4-20 x 1/2" button head cap screws from the crank.
2. Place the crank in the desired position.
3. Replace the screws.

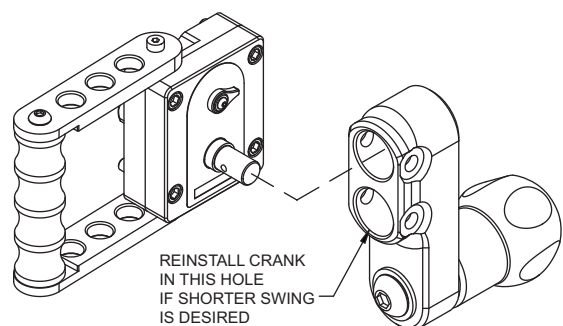

Figure 4.2

5.0 USE

5.1 ATTACHING TO A HYDRANT

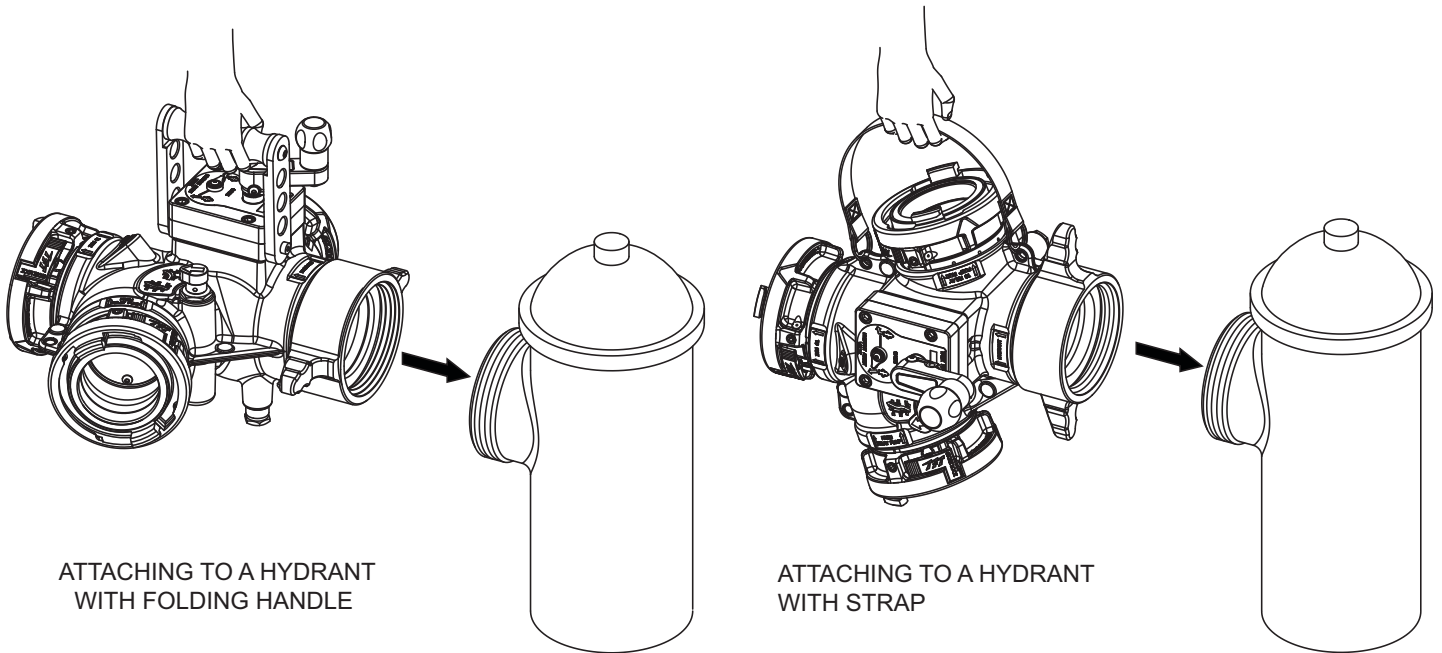

Figure 5.1

5.2 HYDRANT ASSIST OPERATION

5.2.1 MODE 1 (STRAIGHT THRU VALVE)

1. Attach the inlet port marked "Hydrant" either directly to a hydrant, to a supply line connected to a hydrant, or to a supply line connected to the discharge of an assist pumper.
2. Attach one end of a supply hose to the port on the valve marked "TO FIRE" and the other end to the intake port of the attack pumper.
3. Rotate the crank on top of the valve counterclockwise until the crank stops.
4. Open hydrant slowly when ready to flow.

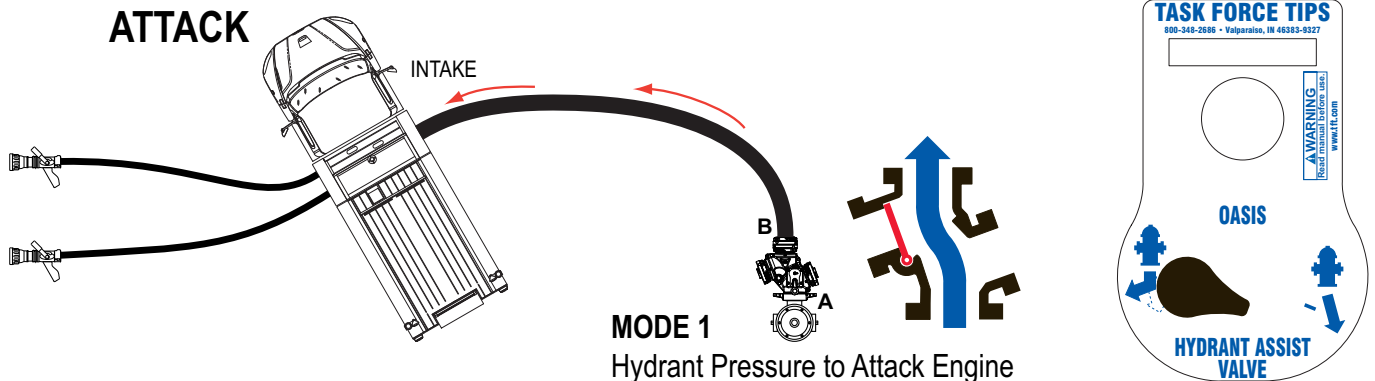

Figure 5.2.1

5.2.2 MODE 2 (BOOST)

1. Attach valve to hydrant and attack pumper and establish flow per MODE 1 instructions.
2. Attach one end of a supply hose to the port on the valve marked "TO RELAY PUMP INLET" and the other end to the intake port of the assist pumper.
3. Attach one end of a supply hose to the port on the valve marked "FROM RELAY PUMP" and the other end to the discharge port of the assist pumper.
4. Rotate the crank on top of the valve clockwise until the crank stops and the indicator on the gear box points to Assist mode.

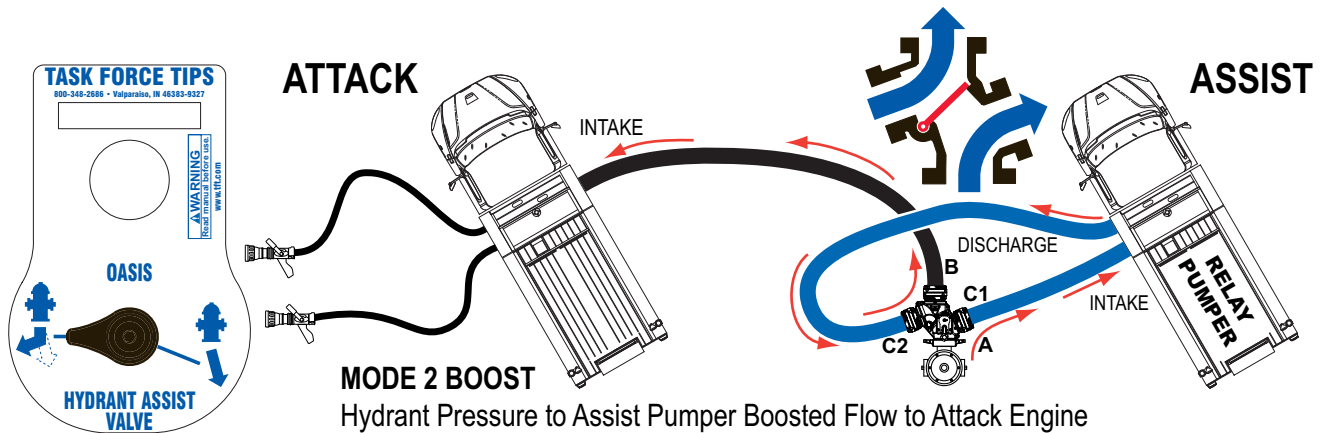

Figure 5.2.2

5.2.3 RELAY OPERATION (STRAIGHT THRU VALVE)

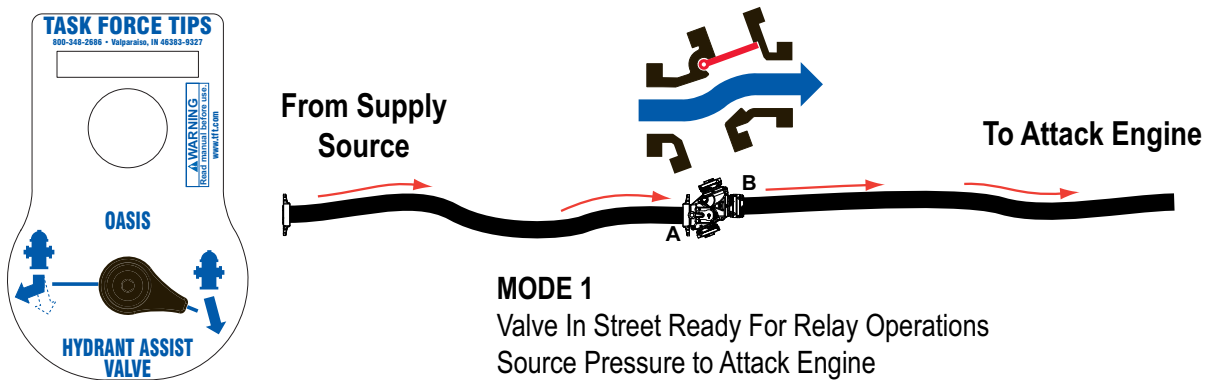

Figure 5.2.3

5.2.4 RELAY OPERATIONS (BOOST)

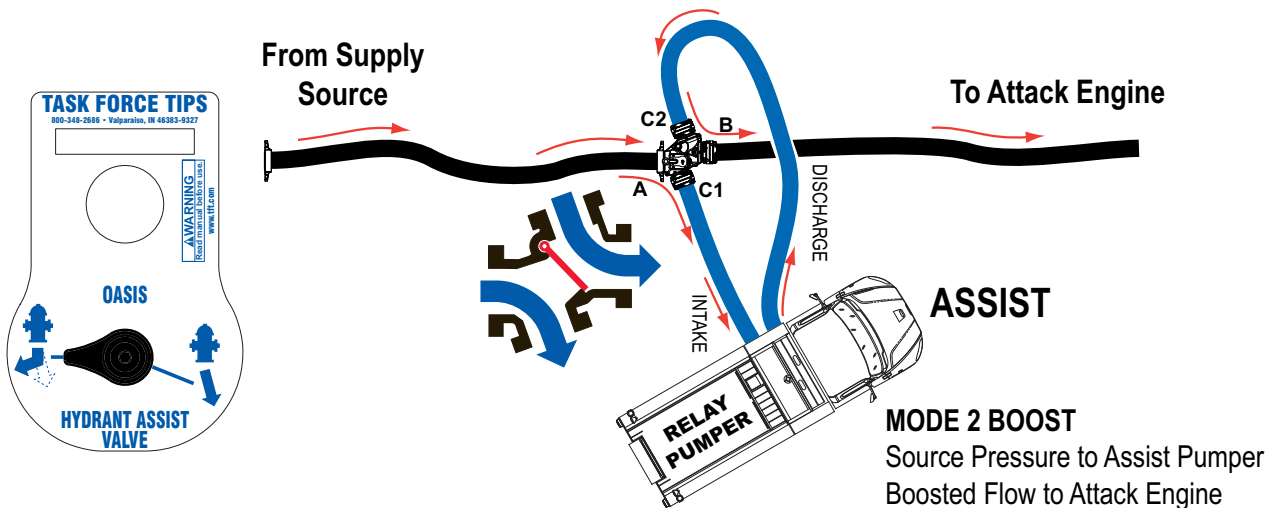

Figure 5.2.4

5.3 CLAPPER VALVE POSITION INDICATOR

5.3.1 MODE 1 (STRAIGHT THRU VALVE)

The clapper valve automatically controls whether water is supplied to the attack pumper directly from the hydrant (at hydrant pressure), or from a relaying pumper (at boosted pressure). When water pressure is supplied to the “HYDRANT” port and no boost pressure is being supplied to the “FROM RELAY PUMP” port, the indicator will show the clapper shutting off the “FROM RELAY PUMP” port and allowing water to flow directly from the “HYDRANT” port to the “TO FIRE” port.

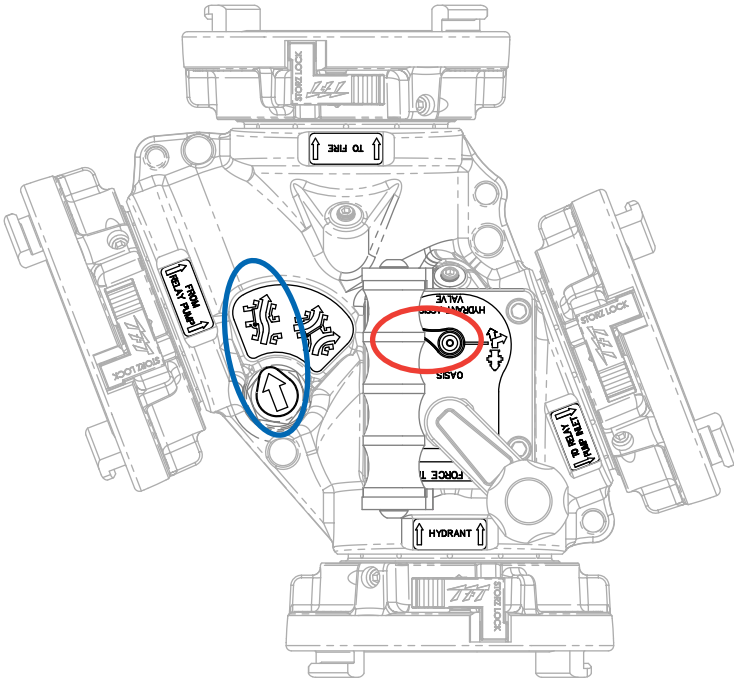
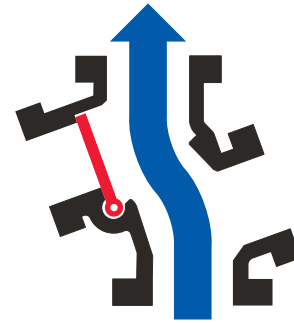

Figure 5.3.1

MODE 1

BALL VALVE INDICATOR showing crank rotated counterclockwise, shutting off “TO RELAY PUMP INLET”.

CLAPPER INDICATOR showing clapper shutting off “FROM PUMP RELAY” port and allowing water to flow directly from the “HYDRANT” port to the “TO FIRE” port.



5.3.2 MODE 2 (BOOST)

When water is supplied from a relaying pumper to the “FROM RELAY PUMP” port at a pressure in excess of hydrant pressure, the clapper valve closes an inner port that diverts all hydrant water to the assist pumper through the “TO RELAY PUMP INLET” port, and allows water to flow directly from the “FROM RELAY PUMP” port to the “TO FIRE” port at a boosted pressure.

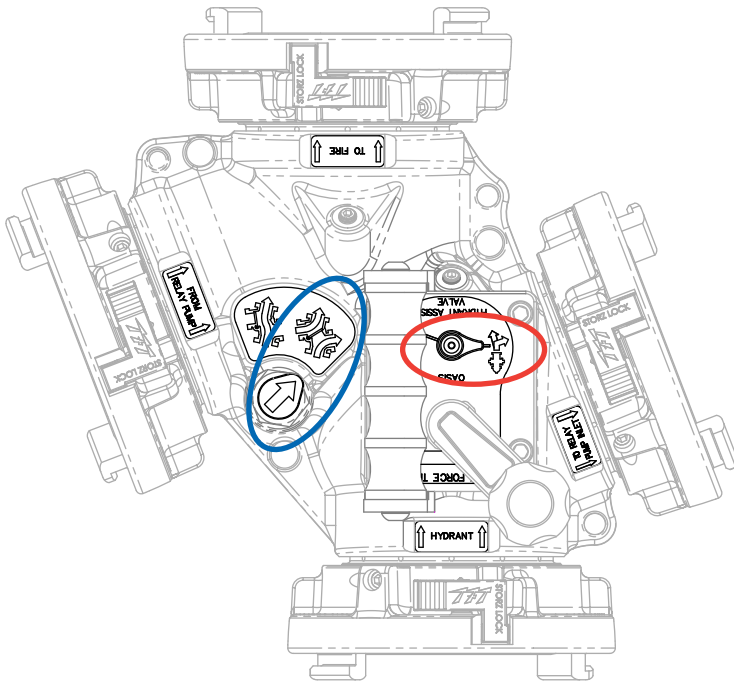
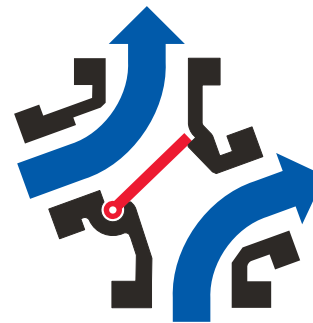

Figure 5.3.2

MODE 2

BALL VALVE INDICATOR showing crank rotated clockwise, opening “TO RELAY PUMP INLET”.

CLAPPER INDICATOR showing clapper shutting off inner port and diverting water from “HYDRANT” port to “TO RELAY PUMP INLET” port and allowing water to flow from the “FROM PUMP RELAY” port to the “TO FIRE” port.



5.4 FLOW INCREASE FROM BOOSTING

FLOW/GPM WITHOUT BOOST			GALLONS OF WATER PER MINUTE FLOWING THROUGH VARIOUS LENGTHS AND SIZES OF HOSE WITH AND WITHOUT PRESSURE ADDED BY BOOST PUMPER					
			4" HOSE			3" HOSE		
			500 ft.	1000 ft.	1500 ft.	500 ft.	1000 ft.	1500 ft.
MODE 1	NOMINAL HYDRANT PRESSURE	60	780	550	450	1240	870	710
MODE 2 BOOST	PRESSURE ADDED BY BOOST PUMPER (TOTAL PRESSURE)	90 (150)	1240	870	710	1960	1380	1120
		140 (200)	1430	1010	820	2240	1580	1290

NOTE: (1) Flow rates calculated assuming that 10 psi residual is remaining at the inlet to the attack pumper.

Table 5.4

5.5 VALVE PRESSURE LOSS

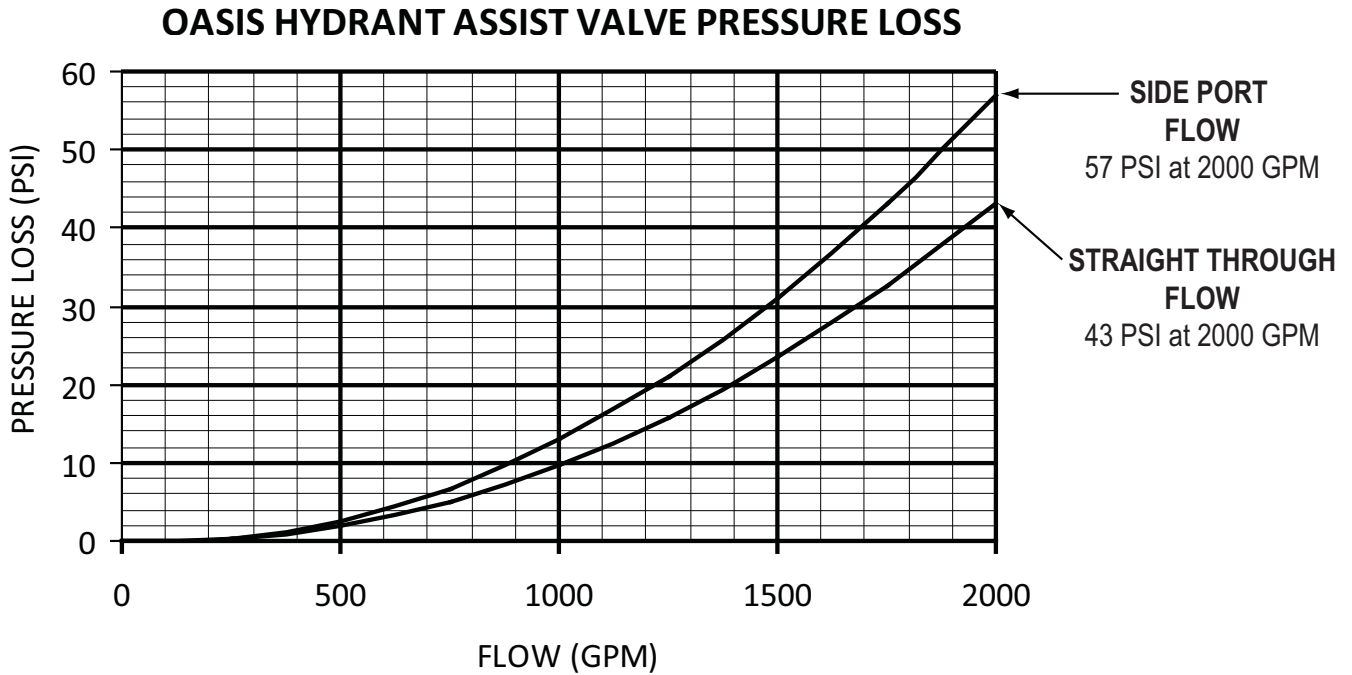
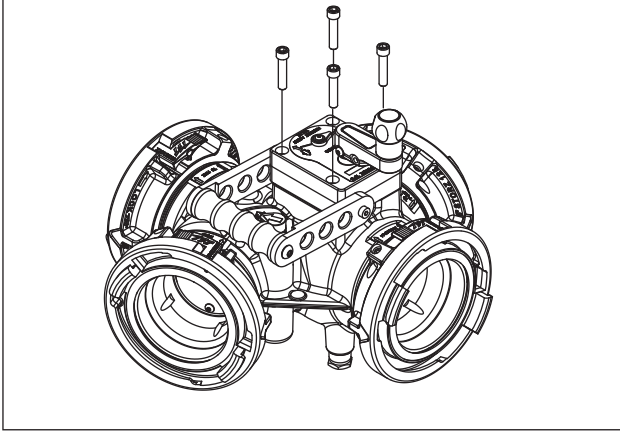

Figure 5.5

6.0 MODIFICATION TO ALLOW SHUT OFF OF THE HYDRANT

1. Remove (4) bolts holding the gearbox in place.



1. Lift the gearbox off of the unit. Note the position of the valve ball.
2. Turn the gearbox over and remove the screw holding the two halves together.

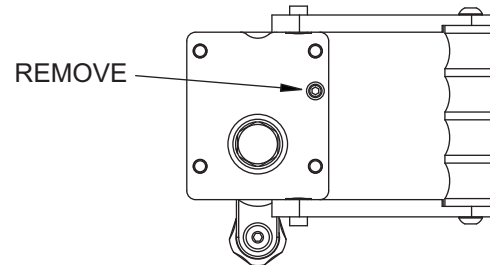

4. Leave the top half in this position until reassembly.
5. Turn the lower half over. Orient the lower section as shown. Remove the stop pin on the LEFT side. DO NOT remove the stop pin on the right side.

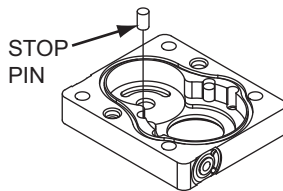

6. Reassemble the upper and lower halves of the gear box.
7. Reinstall the screw removed in Step 3.
8. Ensure the valve ball has not moved and reinstall the gear box on the casting.
9. Apply red Loctite® to all 4 screws and reinstall in a criss-cross pattern until tight.

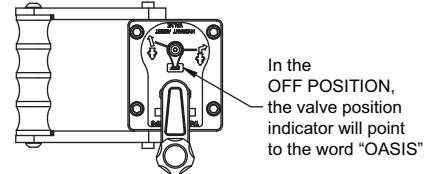

7.0 WARRANTY

Task Force Tips LLC, 3701 Innovation Way, Valparaiso, Indiana 46383-9327 USA ("TFT") warrants to the original purchaser of its products ("equipment"), and to anyone to whom it is transferred, that the equipment shall be free from defects in material and workmanship during the five (5) year period from the date of purchase for mechanical components, and the two (2) year period from the date of purchase for electrical components. TFT's obligation under this warranty is specifically limited to replacing or repairing the equipment (or its parts) which are shown by TFT's examination to be in a defective condition attributable to TFT. To qualify for this limited warranty, the claimant must return the equipment to TFT, at 3701 Innovation Way, Valparaiso, Indiana 46383-9327 USA, within a reasonable time after discovery of the defect. TFT will examine the equipment. If TFT determines that there is a defect attributable to it, TFT will correct the problem within a reasonable time. If the equipment is covered by this limited warranty, TFT will assume the expenses of repair.

If any defect attributable to TFT under this limited warranty cannot be reasonably cured by repair or replacement, TFT may elect to refund the purchase price of the equipment, less reasonable depreciation, in complete discharge of its obligations under this limited warranty. If TFT makes this election, claimant shall return the equipment to TFT free and clear of any liens and encumbrances.

This is a limited warranty. The original purchaser of the equipment, any person to whom it is transferred, and any person who is an intended or unintended beneficiary of the equipment, shall not be entitled to recover from TFT any consequential or incidental damages for injury to person and/or property resulting from any defective equipment manufactured or assembled by TFT.

It is agreed and understood that the price stated for the equipment is in part consideration for limiting TFT's liability. Some states do not allow the exclusion or limitation of incidental or consequential damages, so the above may not apply to you.

TFT shall have no obligation under this limited warranty if the equipment is, or has been, misused or neglected (including failure to provide reasonable maintenance) or if there have been accidents to the equipment or if it has been repaired or altered by someone else.

THIS IS A LIMITED EXPRESS WARRANTY ONLY. TFT EXPRESSLY DISCLAIMS WITH RESPECT TO THE EQUIPMENT ALL IMPLIED WARRANTIES OF MERCHANTABILITY AND ALL IMPLIED WARRANTIES OF FITNESS FOR A PARTICULAR PURPOSE. THERE IS NO WARRANTY OF ANY NATURE MADE BY TFT BEYOND THAT STATED IN THIS DOCUMENT.

This limited warranty gives you specific legal rights, and you may also have other rights which vary from state to state.

8.0 MAINTENANCE

TFT products are designed and manufactured to be damage resistant and require minimal maintenance. However, as the primary firefighting tool upon which your life depends, it should be treated accordingly. The unit should be kept clean and free of dirt by rinsing with water after each use. Any inoperable or damaged parts should be repaired or replaced before placing the unit in service. To help prevent mechanical damage, do not drop or throw equipment.

In applications where appliances are left continuously connected to the apparatus or other devices or are used where water is trapped inside the appliance, the appliance must be flushed with fresh water following each use and inspected for damage.

This appliance should be disconnected, cleaned and visually inspected inside and out at least quarterly, or as water quality and use may require. Moving parts such as handles, valve ball and couplings should be checked for smooth and free operation. Seals shall be greased as needed with Silicone based grease such as Molykote 112. Any scrapes that expose bare aluminum should be cleaned and touched up with enamel paint such as Rust-Oleum. Replace any missing or damaged parts before returning to service.

Any equipment taken out of service due to failure should be returned to the factory for repair or replacement. If you have any questions regarding the testing or maintenance of your valve, please call Task Force Tips at 800-348-2686.

8.0.1 TROUBLESHOOTING

SYMPTOM	POSSIBLE CAUSE	REMEDY
Leaks	Debris or damage in seal area	Clean out debris and/or replace damaged parts

Table 8.0.1

8.1 SERVICE TESTING

In accordance with NFPA 1962, equipment must be tested a minimum of annually. Units failing any part of this test must be removed from service, repaired and retested upon completion of the repair.

8.2 REPAIR

Factory service is available. Factory serviced equipment is repaired by experienced technicians, wet tested to original specifications, and promptly returned. Call TFT service department at 1-800-348-2686 to troubleshoot and, if needed, directions for return. A return for service form can also be obtained at tft.com/Support/Returning-an-Item-for-Service.

Repair parts and service procedures are available for those wishing to perform their own repairs. Task Force Tips assumes no liability for damage to equipment or injury to personnel that is a result of user service. Contact the factory or visit the web site at tft.com for parts lists, exploded views, test procedures and troubleshooting guides.

Performance tests shall be conducted on the equipment after a repair, or anytime a problem is reported to verify operation in accordance with TFT test procedures. Consult factory for the procedure that corresponds to the model and serial number of the equipment. Any equipment which fails the related test criteria should be removed from service immediately. Troubleshooting guides are available with each test procedure or equipment can be returned to the factory for service and testing.



It is the responsibility of service technicians to ensure the use of appropriate protective clothing and equipment. The chosen protective clothing and equipment must provide protection from potential hazards users may encounter while servicing equipment. Requirements for protective clothing and equipment are determined by the Authority Having Jurisdiction (AHJ).



Any alterations to the product or its markings could diminish safety and constitutes a misuse of this product.



All replacement parts must be obtained from the manufacturer to assure proper performance and operation of the device.

9.0 EXPLODED VIEW AND PARTS LISTS

Exploded views and part lists are available at tft.com/serial-number.

10.0 OPERATION AND INSPECTION CHECKLIST

BEFORE EACH USE, equipment must be inspected to this checklist:

1. All valves open and close fully and smoothly.
2. Waterway is clear of obstructions.
3. There is no damage to any thread or other connection.
4. All locks and hold-down devices work properly.
5. The pressure setting on the relief valve (if so equipped) is set correctly.
6. Gaskets are in good condition.
7. There is no obvious damage such as missing, broken or loose parts.
8. There is no damage to the appliance (e.g. dents, cracks, corrosion, or other defects that could impair operation).
9. All swiveling elements rotate freely.
10. There is no corrosion on any surface.
11. There are no missing, worn out or broken lugs on couplings.
12. Hose is securely attached.

BEFORE BEING PLACED BACK IN SERVICE, equipment must be inspected to this list:

1. All valves open and close smoothly and fully.
2. The waterway is clear of obstructions.
3. There is no damage to any thread or other type connection.
4. The pressure setting on the relief valve (if so equipped) is set correctly.
5. All locks and hold-down devices work properly.
6. Internal gaskets are in good condition
7. There is no damage to the appliance (e.g., dents, cracks, corrosion, or other defects that could impair operation).
8. All swiveling connections rotate freely.
9. There are no missing parts or components.
10. The marking for maximum operating pressure is visible.
11. There are no missing, broken, or worn lugs on couplings.



Equipment failing any part of the checklist is unsafe for use and must have the problem corrected before use or being placed back into service. Operating equipment that has failed the checklist is a misuse of this equipment.