

## INSTRUCTION FOR SAFE OPERATION AND MAINTENANCE

### **WARNING**

Understand manual before use. Operation of this device without understanding the manual and receiving proper training is a misuse of this equipment. Obtain safety information at [tft.com/serial-number](http://tft.com/serial-number).

This equipment is intended for use by trained and qualified emergency services personnel for firefighting. All personnel using this equipment shall have completed a course of education approved by the Authority Having Jurisdiction (AHJ).

This instruction manual is intended to familiarize firefighters and maintenance personnel with the operation, servicing, and safety procedures associated with this product. This manual should be kept available to all operating and maintenance personnel.

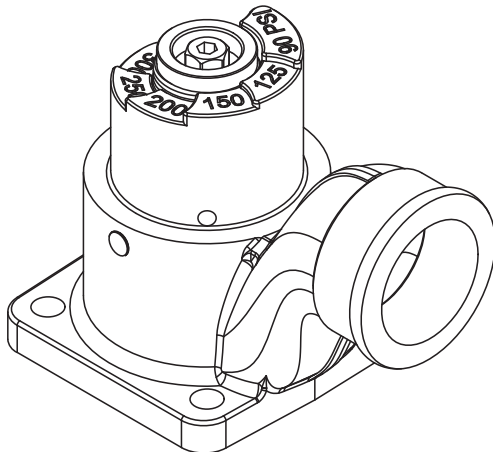

**Flange Mounted PRV**

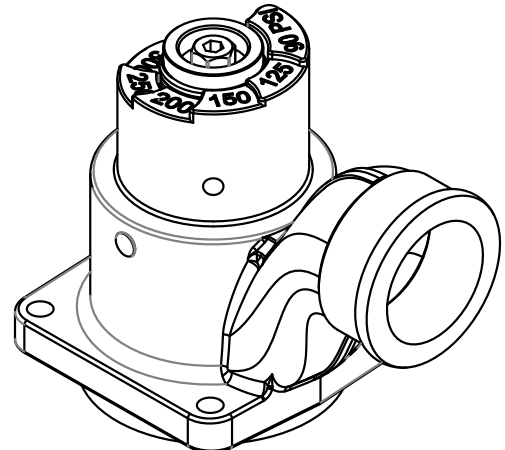

**Flange Mounted PRV  
with Galvanic Isolator**

Flange mounted PRVs are available with a variety of outlets. Consult the catalog, factory, or [tft.com](http://tft.com) to find the configuration for your application.

## TABLE OF CONTENTS

- 1.0 MEANING OF SAFETY SIGNAL WORDS
- 2.0 SAFETY
- 3.0 GENERAL INFORMATION
  - 3.1 FLOW VS. PRESSURE CURVE
  - 3.2 USE WITH SALT WATER
  - 3.3 OVERALL DIMENSIONS
- 4.0 INSTALLATION
- 5.0 RELIEF VALVE PRESSURE SETTING
  - 5.3 PRV OFF SETTING
- 6.0 WARRANTY
- 7.0 MAINTENANCE AND INSPECTION
- 8.0 TESTING

**DANGER**

**PERSONAL RESPONSIBILITY CODE**

The member companies of FEMSA that provide emergency response equipment and services want responders to know and understand the following:

1. Firefighting and Emergency Response are inherently dangerous activities requiring proper training in their hazards and the use of extreme caution at all times.
2. **IT IS YOUR RESPONSIBILITY** to read and understand any user's instructions, including purpose and limitations, provided with any piece of equipment you may be called on to use.
3. **IT IS YOUR RESPONSIBILITY** to know that you have been properly trained in Firefighting and/or Emergency Response and in the use, precautions, and care of any equipment you may be called upon to use.
4. **IT IS YOUR RESPONSIBILITY** to be in proper physical condition and to maintain the personal skill level required to operate any equipment you may be called upon to use.
5. **IT IS YOUR RESPONSIBILITY** to know that your equipment is in operable condition and has been maintained in accordance with the manufacturer's instructions.
6. Failure to follow these guidelines may result in death, burns or other severe injury.

Fire and Emergency Manufacturers and Service Association, Inc.  
PO Box 147, Lynnfield, MA 01940 • www.FEMSA.org

© 2020 FEMSA. All Rights Reserved.

## 1.0 MEANING OF SAFETY SIGNAL WORDS

A safety related message is identified by a safety alert symbol and a signal word to indicate the level of risk involved with a particular hazard. Per ANSI Z535.6, the definitions of the four signal words are as follows:



**DANGER** indicates a hazardous situation which, if not avoided, will result in death or serious injury.



**WARNING** indicates a hazardous situation which, if not avoided, could result in death or serious injury.



**CAUTION** indicates a potentially hazardous situation which, if not avoided, could result in minor or moderate injury.



**NOTICE** is used to address practices not related to physical injury.

## 2.0 SAFETY



Equipment may be damaged if frozen while containing significant amounts of water. Such damage may be difficult to detect visually. Subsequent pressurization can lead to injury or death. Any time the equipment is subject to possible damage due to freezing, it must be tested and approved for use by qualified personnel before being considered safe for use.



Severe water hammer may cause pressure spikes exceeding the Pressure Relief Valve's capacity. Large spikes can result in injury from ruptured hose or system components. Review flow capacity of the Pressure Relief Valve. Add more PRVs if additional flow capacity is needed. Always operate valves slowly to avoid the risk of water hammer.

### 3.0 GENERAL INFORMATION

The Pressure Relief Valve may be set to any pressure between 90 and 300 psi. Its function is to protect the pump and the supply hose from excess pressure. The relief valve may be mounted with its opening facing the front, back, right, or left. A section of tubing or pipe may be mounted on the round spout to route the water in any direction.

<b>Primary Materials</b>	Hard anodized and powder coated aluminum, POM, Nitrile
<b>Operating Temperature Range of Fluid</b>	33 to 120°F (1 to 50°C)
<b>Storage Temperature Range</b>	-40 to 150°F (-40 to 65°C)

Table 3.0

### 3.1 FLOW VS. PRESSURE CURVE

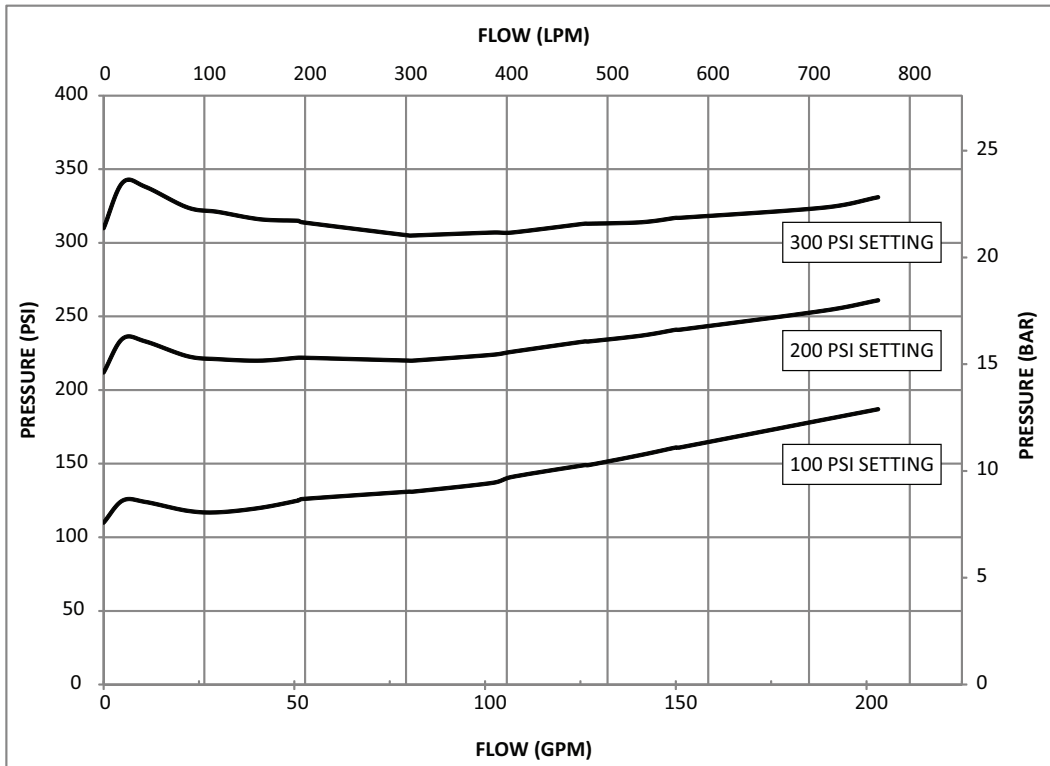

Figure 3.1

### 3.2 USE WITH SALT WATER

Use with salt water is permissible provided the equipment is thoroughly cleaned with fresh water after each use. The service life of the equipment may be shortened due to the effects of corrosion, and is not covered under warranty.

### 3.3 OVERALL DIMENSIONS

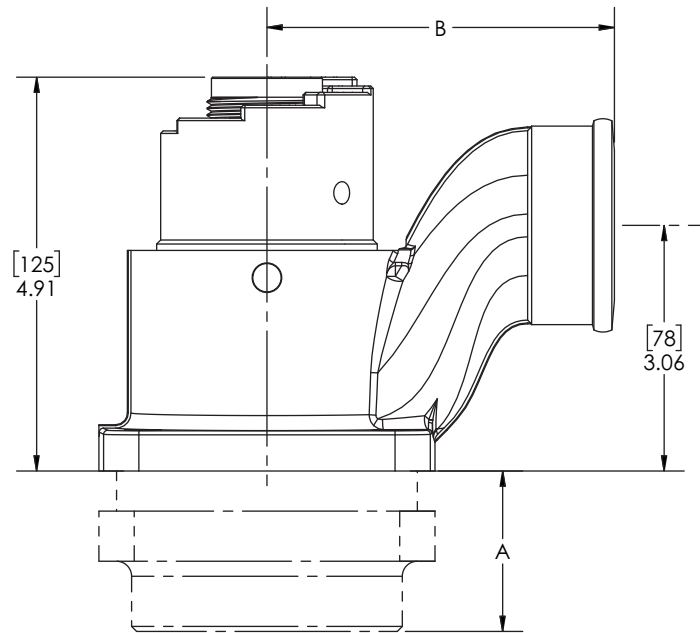

Figure 3.3

<b>A</b>		<b>B</b>	
INLET CONNECTION	INLET HEIGHT	OUTLET CONNECTION	OUTLET LENGTH
STANDARD/DARLEY FLANGE	0.00 [0]	NO EXIT THREADS	4.34 [110]
STANDARD/DARLEY WITH GALVANIC ISOLATOR	0.50 [13]	2.0" NPTM	4.26 [108]
2.5" NPTM WITH GALVANIC ISOLATOR	2.75 [70]	2.5" NPTM	5.53 [141]
2.5" NPTF WITH GALVANIC ISOLATOR	2.00 [51]	2.5" VICTAULIC	5.07 [129]
3.0" NPTM WITH GALVANIC ISOLATOR	2.75 [70]	2.5" NHM	5.57 [141]
3.0" NPTF WITH GALVANIC ISOLATOR	2.38 [60]	2.5" NPTF	5.57 [141]

Dimensions in inches [millimeters]

Table 3.3

Visit [TFT.com](http://TFT.com) for more detailed drawings, specifications, feature lists, and certifications specific to your model number.

## NOTICE

**PRV configurations for use on fire apparatus plumbing, or connected to a metal other than aluminum include an integrated galvanic isolator. These models are 1/2" taller than those mounted to TFT appliances.**

## 4.0 INSTALLATION

To install the flange mounted Pressure Relief Valve:

Required parts:

- (4) 7/16" bolts of appropriate length for your application (Models with a galvanic isolator require 1/2" longer bolts)
  - Thread locking compound such as Loctite 242
  - Torque wrench
  - O-ring (provided)
1. Install the O-ring in the groove on either the Pressure Relief Valve casting or the integrated galvanic isolator.
  2. Place the PRV in the desired orientation. Be sure that the PRV is aligned with the opening. Tightening the bolts with the PRV tilted to one side may damage the galvanic isolator.
  3. Apply a drop of thread locking compound on the threads of the bolts to prevent them from coming loose.
  4. Loosely install the bolts through the flange of the PRV.
  5. Uniformly tighten the bolts 3 time each in an alternating pattern to a final torque of 140in/lb.

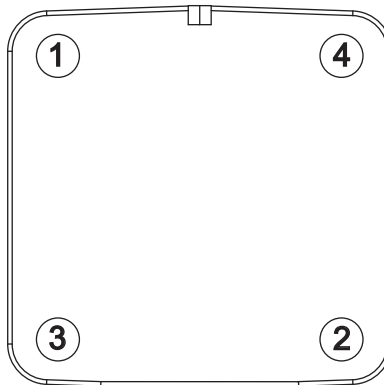

**Tighten bolts in an alternating pattern as shown at left. Complete the pattern for each bolt first to 40 in/lb, then to 80 in/lb, and finally to 140 in/lb.**

Figure 4.0

## 5.0 RELIEF VALVE PRESSURE SETTING

To set the relief valve pressure, turn the adjusting screw on the relief valve housing until the surface of the screw is even with the step marked with the desired pressure.

**Do not cap or plug discharge opening.**

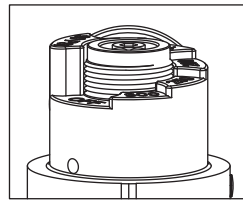
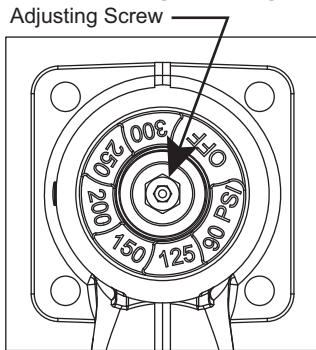

**90 PSI**

Use a 1/4" (7mm) hex key or 9/16" (14mm) socket/wrench when setting the height of the adjusting screw to the desired relief pressure.

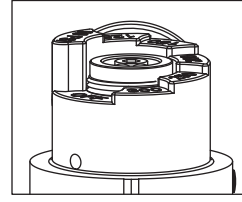

**200 PSI**

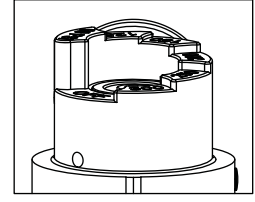

**OFF**

Figure 5.0A

There is a patch of Torque Seal on the seam of the PRV between the Spring Housing and PRV Body just above the set screw. This patch must remain unbroken after setting the PRV. A broken seal indicates that the spring housing moved out of position during setting. If the seal is broken, contact the TFT service team.



**Torque Seal Intact**

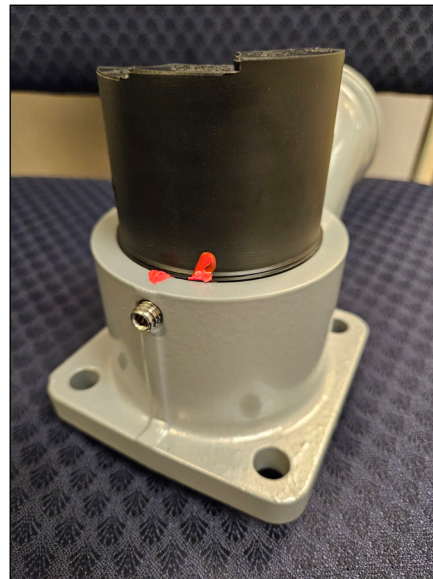

**Torque Seal Broken  
Contact TFT Service Department**

Figure 5.0B

## 5.3 PRV OFF SETTING

To turn off the Pressure Relief Valve, align the adjusting screw with the OFF position. Placing the Pressure Relief Valve in the OFF position prevents the valve from venting water. Do not use the OFF position for normal operations. System damage may occur if the Pressure Relief Valve is in the OFF position and the system exceeds its operating limits.

The Pressure Relief Valve meets the requirements of NFPA 1900.



**The Pressure Relief Valve is disabled in the OFF position and offers no system protection against over-pressurization. Avoid water hammer or other pressure spikes during pump tests. Ensure PRV is returned to its normal pressure setting following pump testing.**

## 6.0 WARRANTY

Task Force Tips LLC, 3701 Innovation Way, Valparaiso, Indiana 46383-9327 USA (“TFT”) warrants to the original purchaser of its products (“equipment”), and to anyone to whom it is transferred, that the equipment shall be free from defects in material and workmanship during the five (5) year period from the date of purchase for mechanical components, and the two (2) year period from the date of purchase for electrical components. TFT’s obligation under this warranty is specifically limited to replacing or repairing the equipment (or its parts) which are shown by TFT’s examination to be in a defective condition attributable to TFT. To qualify for this limited warranty, the claimant must return the equipment to TFT, at 3701 Innovation Way, Valparaiso, Indiana 46383-9327 USA, within a reasonable time after discovery of the defect. TFT will examine the equipment. If TFT determines that there is a defect attributable to it, TFT will correct the problem within a reasonable time. If the equipment is covered by this limited warranty, TFT will assume the expenses of repair.

If any defect attributable to TFT under this limited warranty cannot be reasonably cured by repair or replacement, TFT may elect to refund the purchase price of the equipment, less reasonable depreciation, in complete discharge of its obligations under this limited warranty. If TFT makes this election, claimant shall return the equipment to TFT free and clear of any liens and encumbrances.

This is a limited warranty. The original purchaser of the equipment, any person to whom it is transferred, and any person who is an intended or unintended beneficiary of the equipment, shall not be entitled to recover from TFT any consequential or incidental damages for injury to person and/or property resulting from any defective equipment manufactured or assembled by TFT.

It is agreed and understood that the price stated for the equipment is in part consideration for limiting TFT’s liability. Some states do not allow the exclusion or limitation of incidental or consequential damages, so the above may not apply to you.

TFT shall have no obligation under this limited warranty if the equipment is, or has been, misused or neglected (including failure to provide reasonable maintenance) or if there have been accidents to the equipment or if it has been repaired or altered by someone else.

THIS IS A LIMITED EXPRESS WARRANTY ONLY. TFT EXPRESSLY DISCLAIMS WITH RESPECT TO THE EQUIPMENT ALL IMPLIED WARRANTIES OF MERCHANTABILITY AND ALL IMPLIED WARRANTIES OF FITNESS FOR A PARTICULAR PURPOSE. THERE IS NO WARRANTY OF ANY NATURE MADE BY TFT BEYOND THAT STATED IN THIS DOCUMENT.

This limited warranty gives you specific legal rights, and you may also have other rights which vary from state to state.

## 7.0 MAINTENANCE AND INSPECTION

The Pressure Relief Valve requires no routine maintenance but should be tested regularly. Since the Pressure Relief Valve may not need to open in normal use, it is important that it be inspected at least quarterly for proper function per NFPA 1962 or annually per NFPA 1910, depending on the application. In particular, assure that:

- There is no damage such as cracks or dents
- There is no corrosion
- Setting indications are readable
- The waterway is clear of obstructions
- The valve opens at the set pressure

If any problems are found, the Pressure Relief Valve should be removed from service until the problem is corrected. Any repaired Pressure Relief Valve must be tested before being placed in service.

## 8.0 TESTING

It is important that your Pressure Relief Valve (PRV) is functioning properly at all times while in service. A properly functioning PRV prevents dangerous situations and reduces possible injury. In order to ensure the PRV is functioning properly, it should be tested regularly. NFPA standards set forth the minimum requirements and procedures for inspecting and testing these valves. It is strongly recommended that you read and follow the procedures.

### **For PRVs mounted to piping of in-service emergency vehicles:**

NFPA 1901: Standard for the Inspection, Maintenance, Refurbishment, Testing, and Retirement of In-Service Emergency Vehicles and Marine Firefighting Vessels.

### **For PRVs mounted to a fire hose appliance:**

NFPA 1962: Standard for the Care, Use, Inspection, Service Testing, and Replacement of Fire Hose, Couplings, Nozzles, and Fire Hose Appliances

Any valves taken out of service due to failure should be returned to the factory for repair or replacement. If you have any questions regarding the testing or maintenance of your Pressure Relief Valve, please call Task Force Tips at 800-348-2686.