

PRODUCT BULLETIN

6" Storz Coupling Lockout

A design change has been had to replace the internal lockout ball with an external locking screw on many LDH products. This change affects the following products:

Detent Elbow	LDH Wye	BIV
Adapters	Elbows	Water Thief
3/4/5-Way Manifold	Oasis Hydrant Assist Valve	Siamese
Jumbo Wye	Low Level Strainer	

PREVIOUS DESIGN THROUGH 12/2021

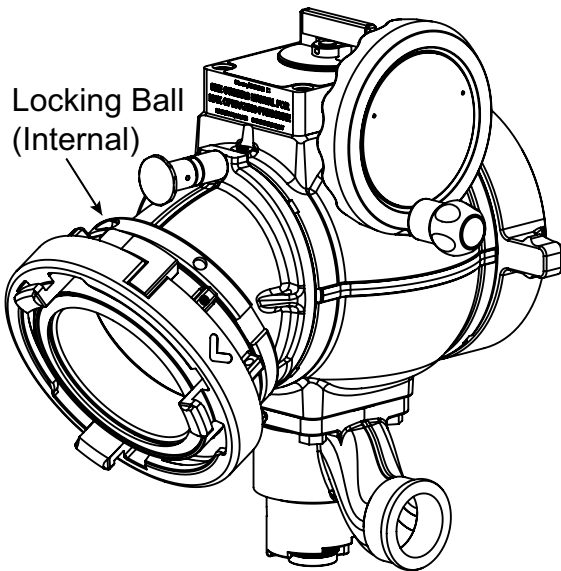

UPDATED DESIGN BEGINNING 1/2022

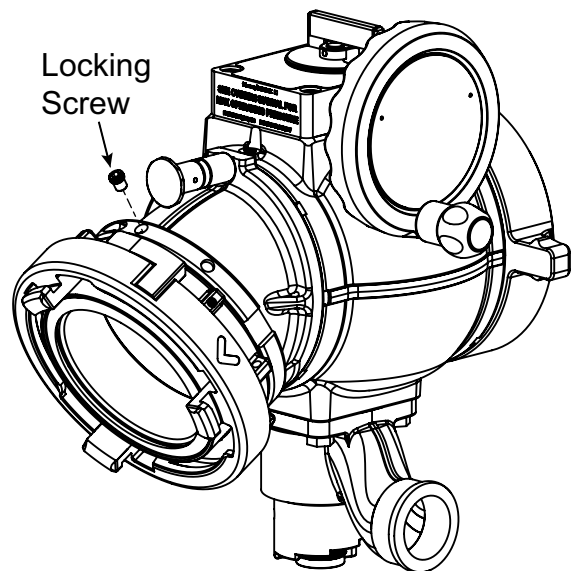

Features and Benefits		
	PREVIOUS DESIGN	UPDATED DESIGN
Rigid/Swivel Capable	Yes	Yes
Method for Achieving Rigid Setting	Internal Stainless Steel Ball	External Set Screw
Ease of Changing Between Settings	Difficult and time consuming <ul style="list-style-type: none"> • Special tool required to remove polymer bearing ring • Special Stainless Steel ball inserted to change to lockout (or removed to change to swivel) before reassembly 	Fast and simple <ul style="list-style-type: none"> • Use a 7/32" hex key to adjust the set screw • Swivel - Back out until the screw is flush. • Lockout - Drive in until the screw bottoms out, then back off one quarter-turn.
Cost and Time Required to Change Settings	Requires special tool and stainless steel ball to be purchased prior to changing setting	None <ul style="list-style-type: none"> • Immediately changeable by the end user - two options in one product