

HURRICANE™ MONITOR SERIES

INSTRUCTION FOR INSTALLATION, OPERATION, AND MAINTENANCE

⚠ DANGER

Understand manual before use. Operation of this device without understanding the manual and receiving proper training is a misuse of this equipment. Obtain safety information at tft.com/serial-number.

This equipment is intended for use by trained and qualified emergency services personnel for firefighting. All personnel using this equipment shall have completed a course of education approved by the Authority Having Jurisdiction (AHJ).

This instruction manual is intended to familiarize firefighters and maintenance personnel with the operation, servicing, and safety procedures associated with this product. This manual should be kept available to all operating and maintenance personnel.

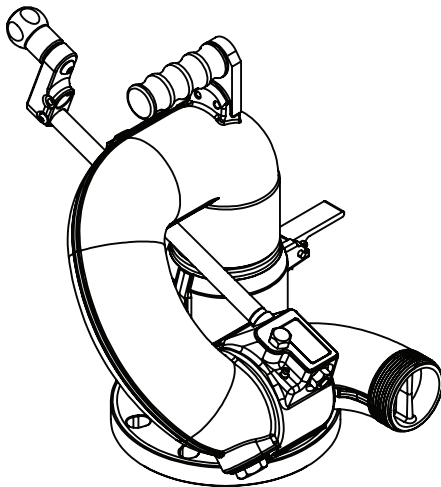

Hurricane Extended

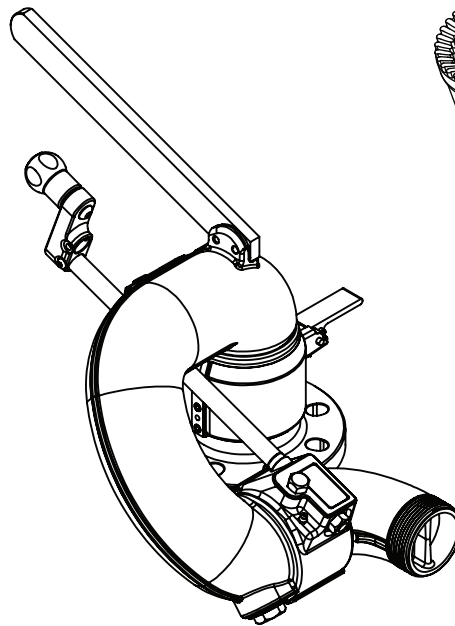

Hurricane

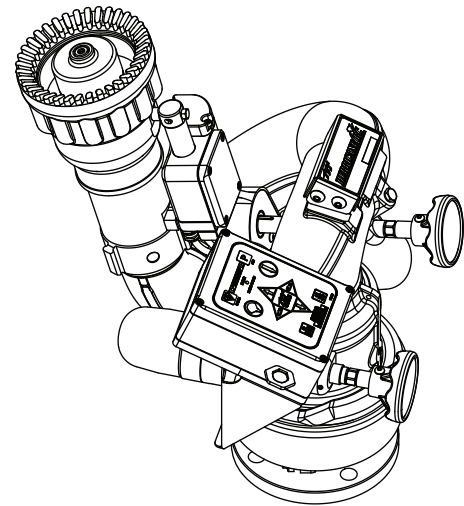

See [Section 3.3](#) for
Flow/Pressure Operating Envelope

DANGER

PERSONAL RESPONSIBILITY CODE

The member companies of FEMSA that provide emergency response equipment and services want responders to know and understand the following:

1. **Firefighting and Emergency Response are inherently dangerous activities requiring proper training in their hazards and the use of extreme caution at all times.**
2. **IT IS YOUR RESPONSIBILITY to read and understand any user's instructions, including purpose and limitations, provided with any piece of equipment you may be called on to use.**
3. **IT IS YOUR RESPONSIBILITY to know that you have been properly trained in Firefighting and/or Emergency Response and in the use, precautions, and care of any equipment you may be called upon to use.**
4. **IT IS YOUR RESPONSIBILITY to be in proper physical condition and to maintain the personal skill level required to operate any equipment you may be called upon to use.**
5. **IT IS YOUR RESPONSIBILITY to know that your equipment is in operable condition and has been maintained in accordance with the manufacturer's instructions.**
6. **Failure to follow these guidelines may result in death, burns or other severe injury.**

Fire and Emergency Manufacturers and Service Association, Inc.
PO Box 147, Lynnfield, MA 01940 • www.FEMSA.org



© 2020 FEMSA. All Rights Reserved.

SUPPORTING MATERIALS

The following documents contain supporting safety and operating information pertaining to the equipment described in this manual.

TASK FORCE TIPS
FIRE FIGHTING EQUIPMENT

MANUAL: Remote Control (RC) Monitor Electrical Controls
Supplemental Instructions for use with RC Monitor Manual

INSTRUCTIONS FOR INSTALLATION, SAFE OPERATION AND MAINTENANCE
Understand manual before use. Operation of this device without understanding the manual and receiving proper training is a misuse of this equipment. Obtain safety information at www.tfi.com/remotecontrol.

⚠ DANGER

SECTION 3.0
General Information and Specifications

SECTION 4.0
Electrical Controls Installation and Operation

SECTION 4.1
Monitor Mounted Operator Station (VBE-COMM)

SECTION 4.2
Panel Mount Operator Station (VBE-SP)

SECTION 4.3
Power Mouse With Display Operator Station (VBE-PM)

SECTION 4.4
Infrared Operator Station (VBE-IR)

SECTION 4.5
Infrared Operator Station With Display (VBE-CT-PM-D)

SECTION 4.6
Monitor Operator Station (VBE-M)

SECTION 4.7
Monitor Operator Station With Display (VBE-CT-M)

SECTION 4.8
Optical Operator Station (VBE-OS)

SECTION 4.9
Tactile Operator Station (VBE-TS)

SECTION 4.10
Toggle Switch Monitor Operator Station (VBE-TS)

SECTION 4.11
Monitor Communication Interface Control (VBE-COMM)

SECTION 4.12
Monitor Position Display (VBE-OSD)

SECTION 4.13
Monitor Position Function Interface Control (VBE-OSD)

SECTION 4.14
Electric RC Monitor Aerial Trench Indicator (VBE-AT)

SECTION 4.15
Multiple Interface Control (VBE-CAM)

SECTION 4.16
Ethernet Interface Control (VBE-ETH)

SECTION 4.17
Electric Nucleic Actuator (VBE-NA)

SECTION 4.18
Voice Key (VBE-VK)

SECTION 5.0
Troubleshooting

TASK FORCE TIPS LLC
MADE IN USA • 177.com

3701 Innovation Way, Valparaiso, IN 46385-9327 USA
800-346-2686 • 219-462-6161 • Fax 219-464-7155

LIY-500 - Remote Control (RC) Monitor Electrical Controls

TASK FORCE TIPS
FIRE FIGHTING EQUIPMENT

MANUAL: Valve Under Monitor (VUM) Valve Under Monitor Remote Control (VUM RC)

INSTRUCTIONS FOR INSTALLATION, SAFE OPERATION AND MAINTENANCE
Understand manual before use. Operation of this device without understanding the manual and receiving proper training is a misuse of this equipment. Obtain safety information at www.tfi.com/valveundermonitor.

⚠ WARNING

This instruction manual is intended to facilitate safe operation, servicing and safety procedures associated with the Valve Under Monitor or Valve Under Monitor RC. This manual should be kept available to all operating and maintenance personnel.

SAFE OPERATING RANGE:
Up to 2500 gpm below 130 psi * (5000 ftm @ 8' head)
Up to 2000 gpm below 200 psi * (6000 ftm @ 14' head)
Up to 1500 gpm @ 200 psi maximum* (5000 ftm @ 21' head)

* valid for monitor outlet up to 21" (450mm) tall from the VUM outlet. Read section 4.3 for details.

VUM RC six seconds from open to close Meets NFPA 1901 slow close requirement

Hydraulic Proof Test:
500 psi (35bar)

SAMPLE CONFIGURATIONS

VUM RC with 2" Hose Control and 2.5" Hose Drive (A6E17110)

VUM RC with 2" Hose Control and 2.5" Hose Drive (A6E17110)

VUM RC with 2" Hose Control and 2.5" Hose Drive (A6E17110)

VUM RC with 2" Hose Control and 2.5" Hose Drive (A6E17110)

TASK FORCE TIPS LLC
MADE IN USA • 177.com

3701 Innovation Way, Valparaiso, IN 46385-9327 USA
800-346-2686 • 219-462-6161 • Fax 219-464-7155

LIA-285 - Valve Under Monitor (VUM) Valve Under Monitor Remote Control (VUM RC)

TASK FORCE TIPS
FIRE FIGHTING EQUIPMENT

Extend-A-Gun RC3 & RC4 Remote Control Telescoping Waterway for Deck Mounted Monitors

INSTRUCTIONS FOR INSTALLATION, SAFE OPERATION, AND MAINTENANCE
Understand manual before use. Operation of this device without understanding the manual and receiving proper training is a misuse of this equipment. Obtain safety information at www.tfi.com/extend-a-gun.

⚠ DANGER

This equipment is intended for use by trained and qualified emergency services personnel for firefighting. All personnel using this equipment shall have completed a course of education approved by the Authority Having Jurisdiction (AHJ). This instruction manual is intended to facilitate safe operation, servicing and safety procedures associated with the operation, servicing, and safety procedures associated with this product. This manual should be kept available to all operating and maintenance personnel.

CONTROL BOX
Complies with 10.8.2(m) of power & communication cable for connection to remote communication link & stream.
15.1.1(m) of cable for connection to RC remote and 12.1.3.5(m) of cable for connection to RC Extend-A-Gun motor.

OPTIONAL POWERED FOR EXTENSION:
(compatible with 12.8.2.5(m) cable for connection to control box)

Shown with Monitor RC Monitor and Master 2000 Nozzle (Monitor Nozzle and Mounting Brackets not included)

TASK FORCE TIPS LLC
MADE IN USA • 177.com

3701 Innovation Way, Valparaiso, IN 46385-9327 USA
800-346-2686 • 219-462-6161 • Fax 219-464-7155





LIX-530 - Extend-A-Gun RC3 & RC4

TABLE OF CONTENTS







- 1.0 MEANING OF SAFETY SIGNAL WORDS
- 2.0 SAFETY
- 3.0 GENERAL INFORMATION
 - 3.1 MECHANICAL SPECIFICATIONS
 - 3.2 ELECTRICAL SPECIFICATIONS
 - 3.3 OPERATING ENVELOPE
 - 3.4 USE WITH SALT WATER
 - 3.5 VARIOUS MODELS AND TERMS
 - 3.6 OVERALL DIMENSIONS
 - 3.6.1 OVERALL HEIGHT INCREASE FOR INLET FITTINGS
- 4.0 INSTALLATION
 - 4.1 ELECTRICAL INSTALLATION
 - 4.1.1 MOUNTING THE MONITOR
 - 4.2 INLET MOUNTING AND TRAVEL RANGES
 - 4.2.1 INLET FITTING OR EXTEND-A-GUN INSTALLATION
 - 4.3 CABLE ROUTING FOR EXTEND-A-GUN
 - 4.4 HORIZONTAL ROTATION TRAVEL STOPS
 - 4.5 ELEVATION TRAVEL STOPS
 - 4.6 NOZZLE INSTALLATION
 - 4.6.1 ER NOZZLE INSTALLATION ORIENTATION
 - 4.7 PRESSURE GAUGE PORT
 - 4.8 AUTOMATIC DRAIN
 - 4.9 TILLER/HANDLE INSTALLATION
- 5.0 OPERATING INSTRUCTIONS
 - 5.1 HORIZONTAL ROTATIONAL CONTROL
 - 5.2 HANDWHEEL ELEVATION CONTROL
 - 5.3 RECOMMENDED PARK POSITION
 - 5.4 OVERRIDE KNOBS
- 6.0 FLOW CHARACTERISTICS
 - 6.1 MST-4NJ STACKED TIPS FLOW AND REACH
 - 6.1.1 EFFECTS OF ELEVATION AND WIND ON STREAM REACH (2.00" TIP)
 - 6.2 AUTOMATIC MASTERSTREAM NOZZLES
 - 6.3 FRICTION LOSS
 - 6.4 STREAM STRAIGHTENERS
 - 6.4.1 STREAM STRAIGHTENERS WITH STACKED TIPS
 - 6.4.2 STREAM STRAIGHTENERS WITH FOG NOZZLES
- 7.0 WARRANTY
- 8.0 MAINTENANCE
 - 8.1 SERVICE TESTING
 - 8.2 LUBRICATION
 - 8.2.1 ELEVATION CONTROL WORM GEAR
 - 8.2.2 HORIZONTAL ROTATION WORM GEAR
 - 8.3 TROUBLESHOOTING
 - 8.4 REPAIR
- 9.0 EXPLODED VIEWS AND PARTS LISTS
- 10.0 OPERATION AND INSPECTION CHECKLIST

1.0 MEANING OF SAFETY SIGNAL WORDS

A safety related message is identified by a safety alert symbol and a signal word to indicate the level of risk involved with a particular hazard. Per ANSI Z535.6, the definitions of the four signal words are as follows:

-  **DANGER** indicates a hazardous situation which, if not avoided, will result in death or serious injury.
-  **WARNING** indicates a hazardous situation which, if not avoided, could result in death or serious injury.
-  **CAUTION** indicates a potentially hazardous situation which, if not avoided, could result in minor or moderate injury.
-  **NOTICE** is used to address practices not related to physical injury.

2.0 SAFETY

-  **DANGER** An inadequate supply of pressure and/or flow will cause an ineffective stream and can result in injury or death. Choose operating conditions to deliver adequate fire suppression. See flow graphs.
-  **WARNING** Injury or damage can occur from an inadequately supported monitor. The mounting must be capable of supporting the nozzle reaction force which can be as high as 1500 lbs.
-  **WARNING** The stream exiting a nozzle is very powerful and capable of causing injury and property damage. Make sure the nozzle is securely attached and pointing in a safe direction before water is turned on. Do not direct water stream to cause injury or damage to persons or property.
-  **WARNING** Equipment may be damaged if frozen while containing significant amounts of water. Such damage may be difficult to detect visually. Subsequent pressurization can lead to injury or death. Any time the equipment is subject to possible damage due to freezing, it must be tested and approved for use by qualified personnel before being considered safe for use.
-  **WARNING** On many vehicle installations, the monitor is the highest point on the apparatus. Damage or injury could occur if there is not sufficient clearance to safely pass under doors or overhead obstructions. Always check stowed position of the monitor before moving.
-  **CAUTION** The electric drives are current limited but may still produce enough force to cause injury. To avoid injury from moving equipment:
 - Be aware that equipment may be remotely operated
 - Keep hands and fingers away from pinch points
 - Never operate the manual override while electric controls are in operation

3.0 GENERAL INFORMATION

The Task Force Tips HURRICANE Monitor is a simple, yet effective, fixed location master stream device available in manual and RC versions.

3.1 MECHANICAL SPECIFICATIONS

	MANUAL		ELECTRIC	
	US	METRIC	US	METRIC
Weight	23 lbs	10.4 kg	39 lbs	17.7 kg
Minimum Flow Area	7.07 in ²	45.6 cm ²	12.6 in ²	81.1 cm ²
Maximum Flow	1250 gpm	5000 L/min	1250 gpm	5000 L/min
Maximum Operating Pressure	200 psi	14 bar	200 psi	14 bar
Nozzle Reaction Force at Max Flow	1100 lbs	500 kg	1100 lbs	500 kg
Operating Temperature Range of Fluid	33°F to 120°F (1°C to 50°C)			
Storage Temperature Range	-40 to 150°F / -40 to 65°C			
Materials	ANSI A356.0-T6 Aluminum, Stainless Steel			

Table 3.1

3.2 ELECTRICAL SPECIFICATIONS

Nominal Operating Voltage	12 or 24 VDC (auto sense)
Minimum Voltage	12 VOLT System 9 VDC at the monitor 24 VOLT System 18 VDC at the monitor
Maximum Voltage	32 VDC
Maximum Torque (Elevation)	60 ft·lbs (80 N·m)
Maximum Torque (Horizontal)	60 ft·lbs (80 N·m)
Speed (Elevation)	9 deg/sec
Speed (Horizontal)	12 deg/sec

Table 3.2

3.3 OPERATING ENVELOPE



Damage or injury could result from operating the monitor beyond the safe operating envelope. Do not operate the monitor outside the envelope in the following graph(s).

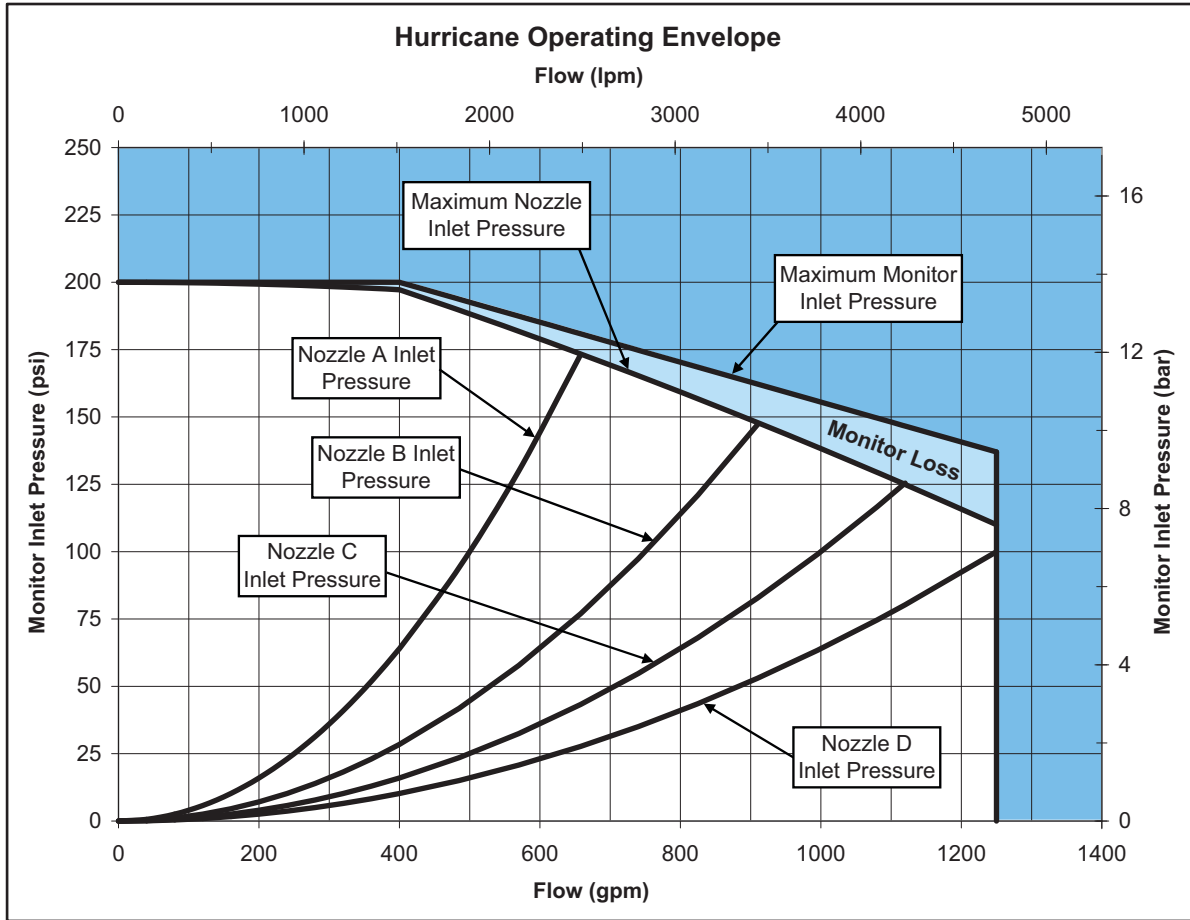

Nozzle A flows 500 gpm (1900 l/min), at 100 psi (7 bar), K factor = 50
 Nozzle B flows 750 gpm (2800 l/min), at 100 PSI (7 bar), K factor = 75
 Nozzle C flows 1000 gpm (3800 l/min), at 100 PSI (7 bar), K factor = 100
 Nozzle D flows 1250 gpm (4700 l/min), at 100 PSI (7 bar), K factor = 125

Figure 3.3

3.4 USE WITH SALT WATER

Use with salt water is permissible provided the equipment is thoroughly cleaned with fresh water after each use. The service life of the equipment may be shortened due to the effects of corrosion, and is not covered under warranty.

To reduce galvanic corrosion, it is highly suggested to use galvanic isolator kits between the monitor & mounting flange. Order Part # Z-G4A150 (4") or Z-G3A150 (3"). For additional protection with 4 inch flanges, we also offer a secondary extended isolator to use in conjunction with the standard isolation gasket kit. Order Part # Z-FIS4A150S



If equipped with a TFT Corrosion Isolation Sleeve, the use of a gasket on either side of the sleeve is required. Do not use a TFT Corrosion Isolation Sleeve as a gasket replacement.

3.5 VARIOUS MODELS AND TERMS

HURRICANE MONITOR (XFI-FPNJ)

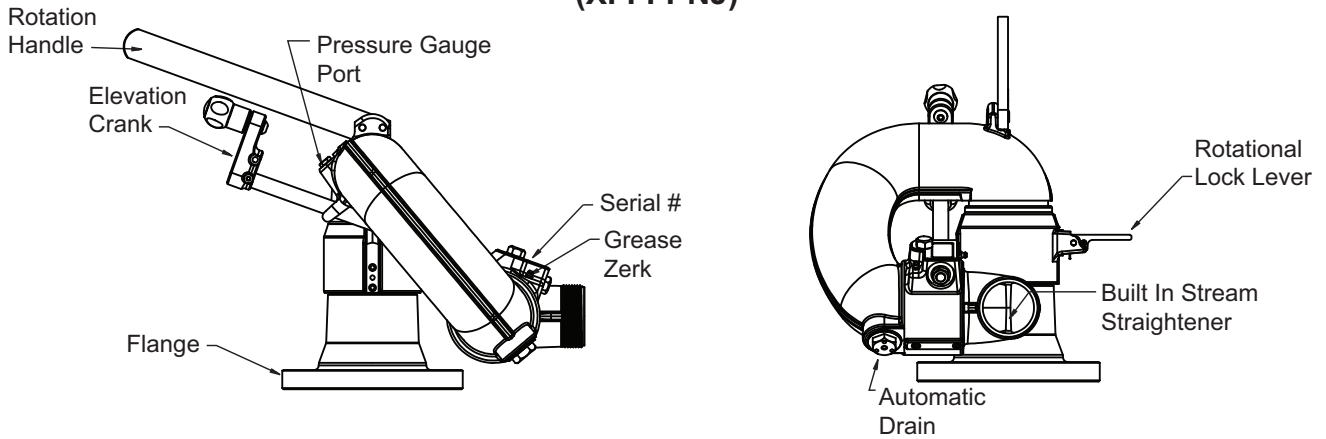

Figure 3.5A

HURRICANE RC (XFIH-E series)

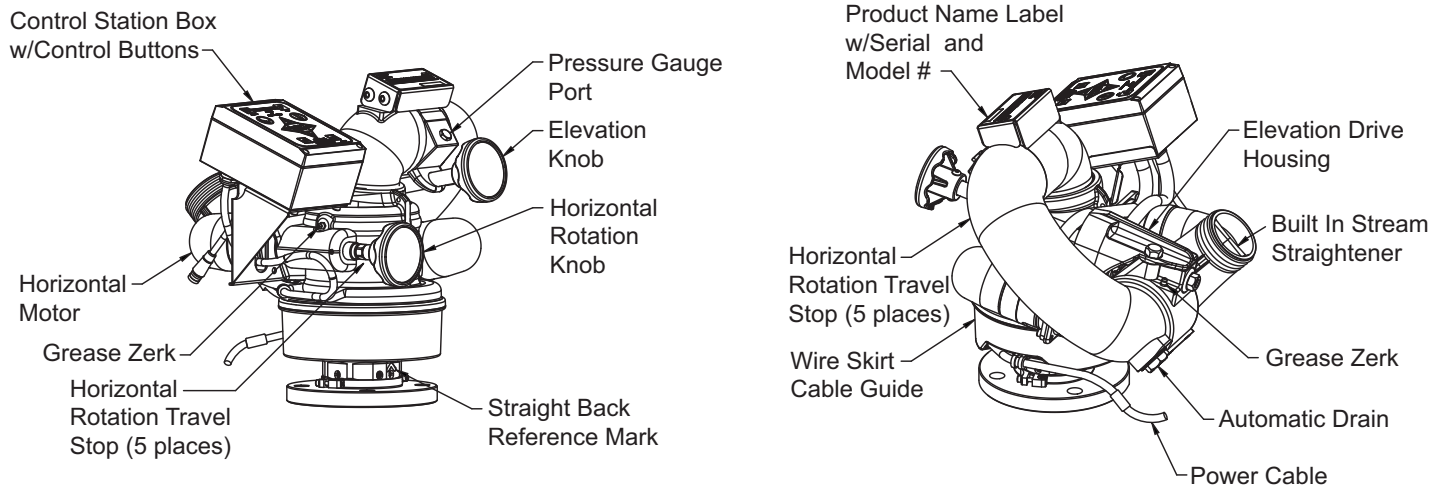

Figure 3.5B

3.6 OVERALL DIMENSIONS

HURRICANE MONITOR with Tiller and 3" ANSI Flange (metric DN80 PN20)

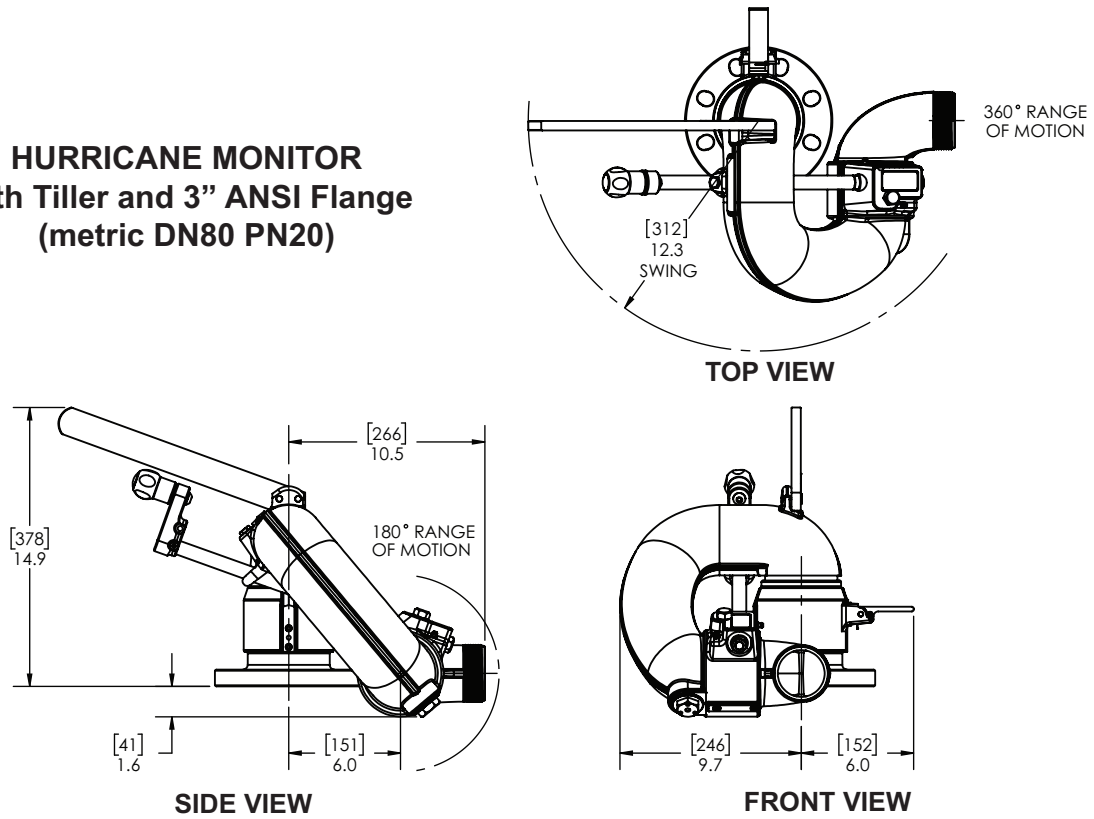

Figure 3.6A

HURRICANE MONITOR with Tiller and 4" ANSI Flange (metric DN100 PN20)

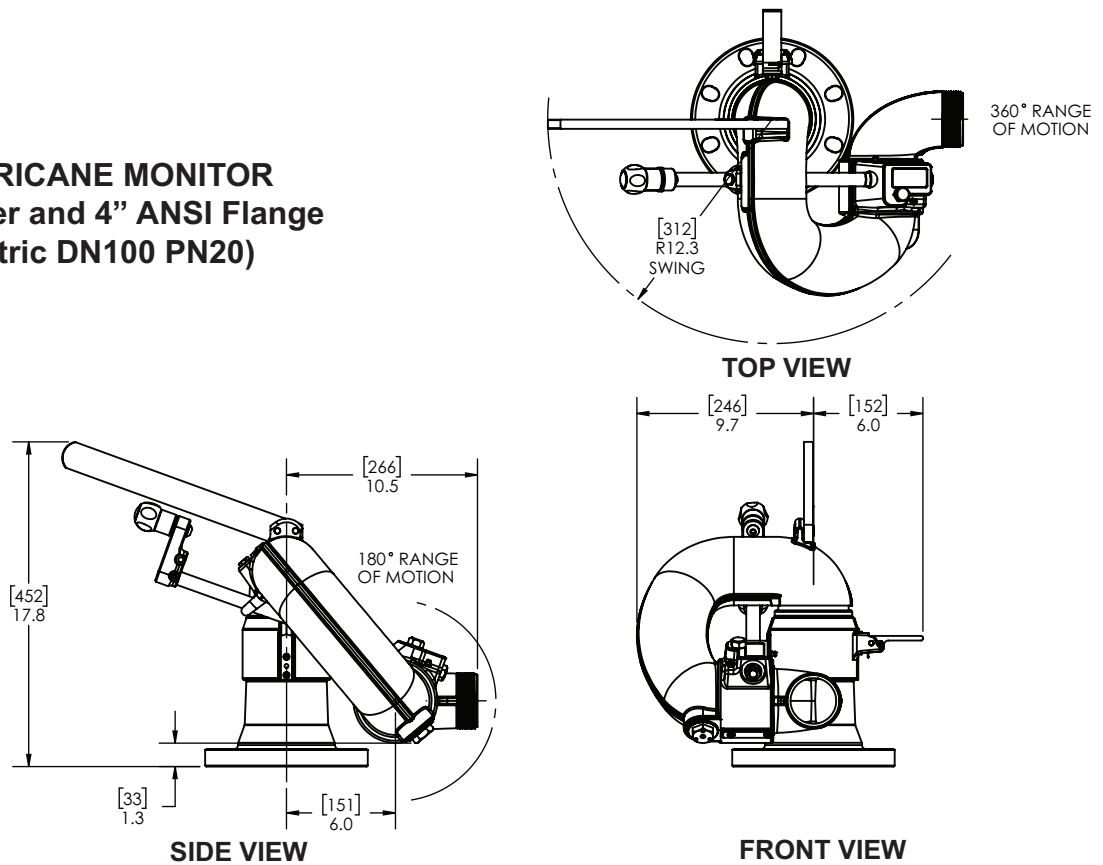

Figure 3.6B

3.6 OVERALL DIMENSIONS (CONTINUED)

**HURRICANE MONITOR
with Tiller and 3" NPT Female Inlet**

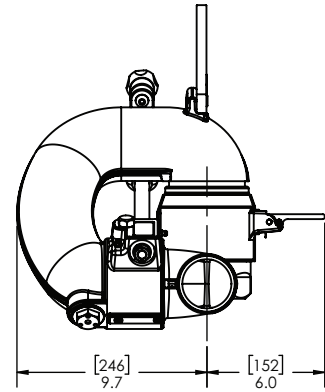
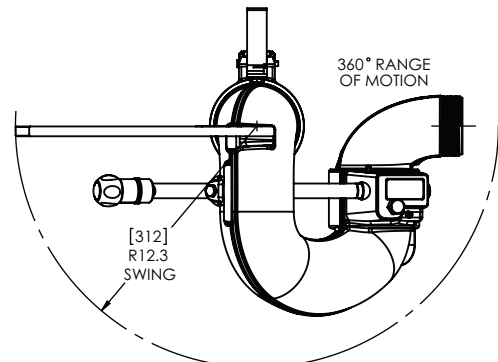
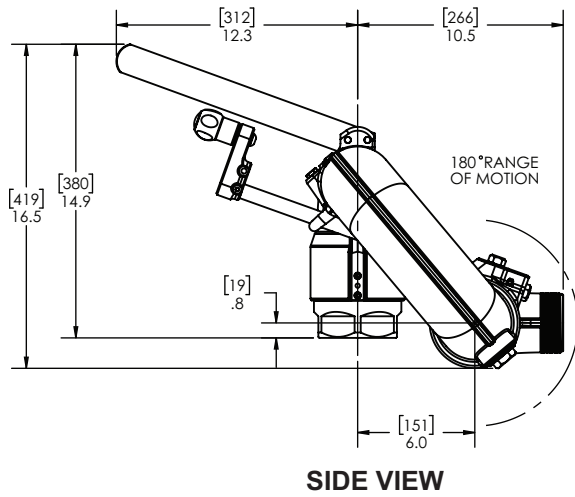

Figure 3.7C

**HURRICANE MONITOR
3" or 4" ANSI 150 Flange
Extended Monitor**

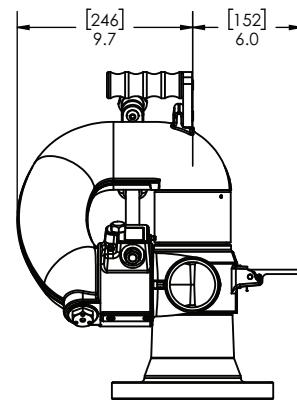
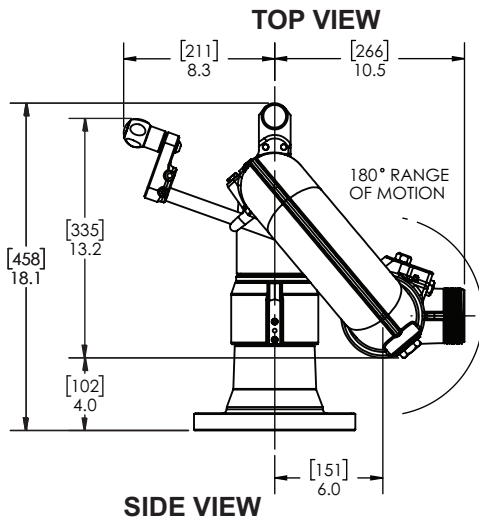
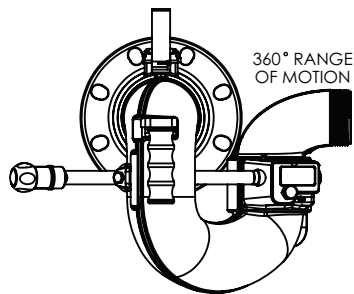
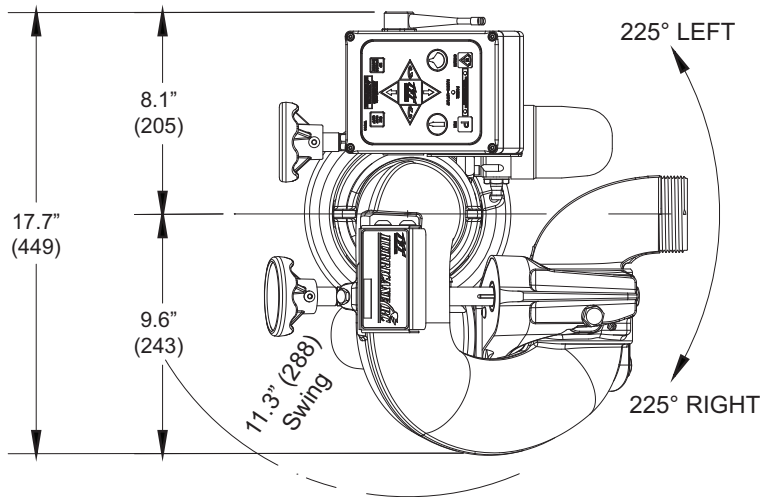

Figure 3.7D

3.6 OVERALL DIMENSIONS (CONTINUED)

HURRICANE RC MONITOR Shown without Inlet Fitting

(see table 3.6.1 for additional height per fitting)



TOP VIEW

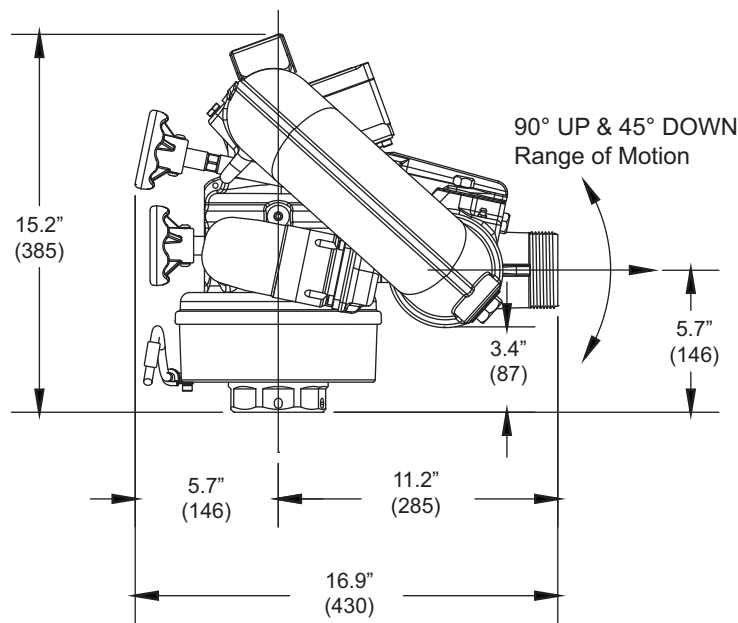

SIDE VIEW

Figure 3.7E

3.6.1 OVERALL HEIGHT INCREASE FOR INLET FITTINGS

The following table shows the overall height increase on Hurricane RC models with certain inlet fittings.

MODEL	INLET FITTING TYPE	ADDITIONAL HEIGHT
XFIH-*1*A	3" ANSI 125/150 (metric DN80 PN16)	.75" (20mm)
XFIH-*2*A	4" ANSI 150 (metric DN100 PN16)	.94" (23mm)
XFIH-*6*A	3" NPT Female	2.00" (51mm)

* These digits in the model number refer to thread size and type.

Figure 3.6.1

4.0 INSTALLATION

4.1 ELECTRICAL INSTALLATION

See Remote Control (RC) Monitor Electrical Controls Supplemental Instructions LIY-500.structural requirements

WARNING

Reaction forces generated by master stream flows are capable of causing injury and property damage if not properly supported. Monitors should be securely installed by qualified individuals.

- Mounting objects must be capable of withstanding maximum nozzle reaction force listed in SPECIFICATIONS.
- The monitor must be securely mounted to rigid support members.
- Do not use flanges or pipe made from plastic for monitor mounting.
- Torque all fasteners to specified values.

The structure that the monitor is mounted to must withstand the internal pressure of the monitor as well as shear and bending forces due to nozzle reaction.

See SPECIFICATIONS for reaction force and maximum flow.

For flanged connections, the use of flat flanges without raised faces is recommended. Use a ring gasket as defined in ASME 16.21 or ISO 7483. Tighten flange bolts in an alternating sequence as shown. Tighten sequentially each bolt or stud three times to 30%, then 60%, and finally 100% of the specified torque per flange listed in the table below.

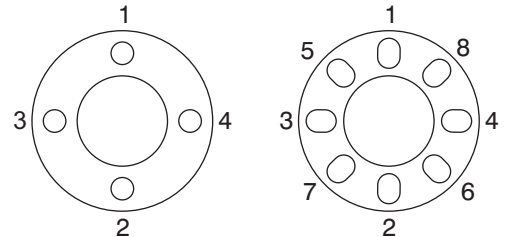

Figure 4.1

NOTE: Bolt holes 5, 6, 7, and 8 are not used with a 3" ANSI Flange connection.

NOTICE

If equipped with a TFT Corrosion Isolation Sleeve, the use of a gasket on either side of the sleeve is required. Do not use a TFT Corrosion Isolation Sleeve as a gasket replacement.

FLANGE TYPE*	OUTSIDE DIAMETER**		THICKNESS**		BOLT HOLE CIRCLE		NUMBER OF BOLTS	SIZE OF BOLTS		REQUIRED TORQUE	
	in	mm	in	mm	in	mm		in	mm	ft-lb	N-m
2.5" ANSI 150	6.9	175	0.88	23	5.5	140	4	5/8	16	76-80	100-110
3" ANSI 125/150-DN100 PN20***	7.5	190	0.94	24	6.0	152	4	5/8	16	76-80	100-110
4" ANSI 150-DN100 PN20	9.0	230	0.94	24	7.5	191	8	5/8	16	76-80	100-110
6" ANSI 150	10.9	277	1.00	25	9.5	241	8	3/4	19	76-80	100-110
8" ANSI 150	13.5	343	1.125	29	11.75	198	8	3/4	19	150-200	200-270
DN80 PN16	9.0	200	0.79	18	6.3	160	8	5/8	16	76-80	100-110
DN100 PN16	8.7	220	0.87	22	7.1	180	8	5/8	16	76-80	100-110
DN65 AS2129 TABLE E	6.5	165	0.78	20	5.0	127	4	5/8	16	76-80	100-110

*Not every flange type listed in this table is available for this product. Please reference the TFT catalog or tft.com for flanged connection inlet offerings.

**Dimensions listed are from the applicable standard for each flange type and are for reference only. Measure both flanges when selecting bolt length.

***This flange contains 8 bolt holes but only requires 4 bolts for mounting. The additional holes allow a connection to both 3" ANSI 150 and DN80 PN16 flanged connections.

Table 4.1

4.1.1 MOUNTING THE MONITOR

The Hurricane Monitor is mounted on a riser pipe by a bolted flange or threaded joint. The area around the monitor must be free from obstructions which would limit its range of motion and usefulness. If a valve is mounted under the HURRICANE, make sure the monitor will not interfere with the valve handle. If a butterfly valve is mounted under the monitor make sure that the butterfly valve assembly does not interfere with the flanged base.

4.2 INLET MOUNTING AND TRAVEL RANGES

4.2.1 INLET FITTING OR EXTEND-A-GUN INSTALLATION

The Hurricane RC Monitor is available with various inlet fittings. The Hurricane RC Monitor also connects directly to TFT's Extend-A-Gun RC3 or RC4. The fittings and Extend-A-Gun RC are attached to the monitor by means of a threaded joint with an o-ring seal. Install the monitor using the following procedure:

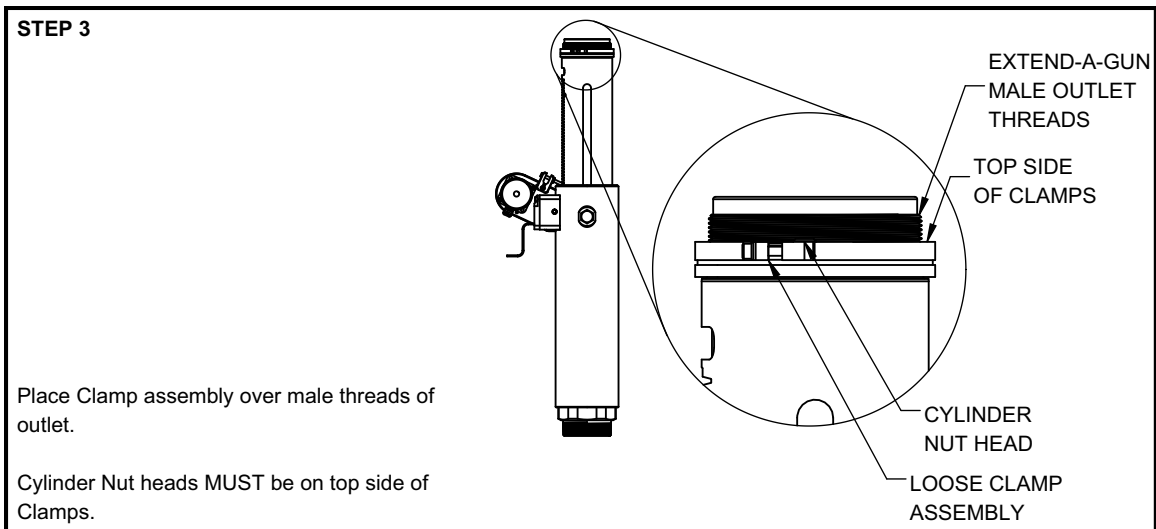
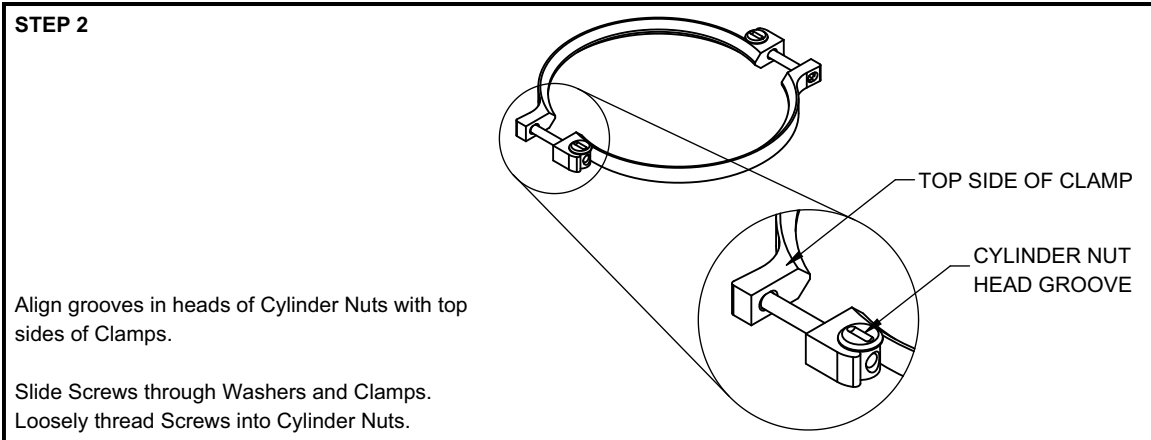
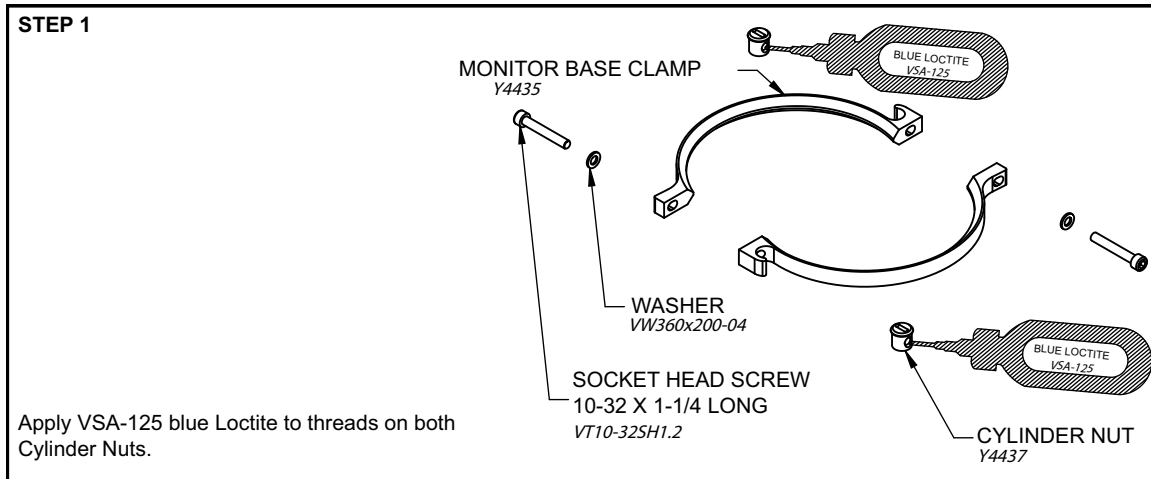

STEP 4

Screw monitor onto Extend-A-Gun until monitor base bottoms out against Extend-A-Gun outlet.

Threaded joint seals with an O-ring and will leak if monitor base bottoms out on Clamp assembly instead of Extend-A-Gun outlet.

Do not use pipe dope or Loctite on threads. Use of thread locking compounds is unnecessary and will make removal difficult.

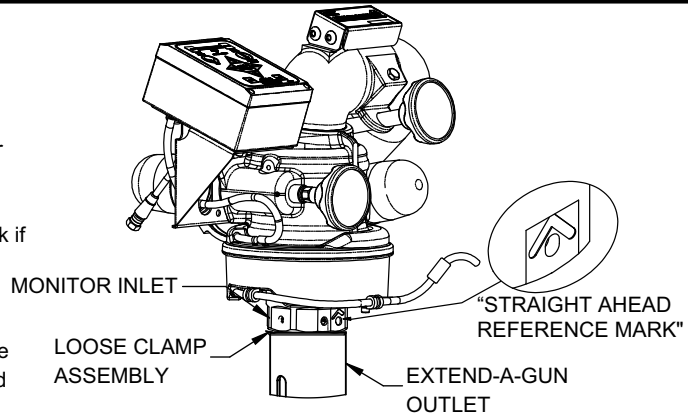

STEP 5

Unscrew monitor base from Extend-A-Gun outlet until the "Straight Ahead Reference Mark" is facing the desired direction.

Monitor may be unscrewed up to one full rotation from bottomed-out condition. Monitor will leak if unthreaded more than one rotation (360°) from bottomed-out condition.

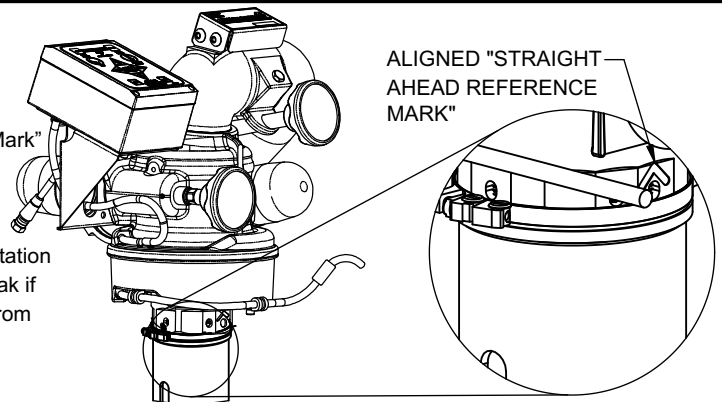

WIRE SKIRT NOT SHOWN FOR ILLUSTRATION PURPOSES

STEP 6

Rotate clamps to desired position and tighten Screws until finger tight. Maintain equal spacing between Clamp ends.

Tighten Screws one additional turn using a 5/32" (4mm) hex wrench. Alternate Screws with each half-turn to a maximum torque of 30 in-lbs.

To avoid damage to the monitor, ensure Clamps do not interfere with RC monitor Power/Com cable and that Screws are not overtightened.

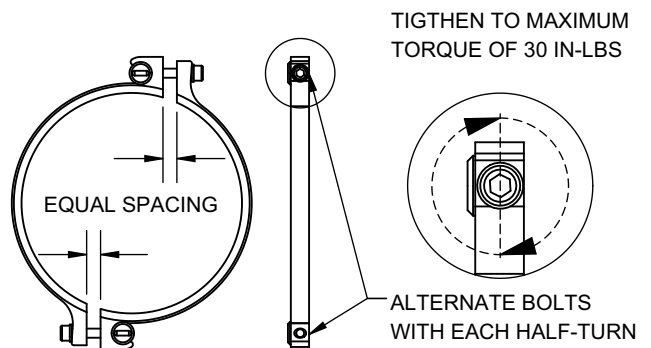

4.3 CABLE ROUTING FOR EXTEND-A-GUN

Hurricane monitor, for use with Extend-A-Gun RC, comes with the wire installed in a nylon tube. The nylon tubing gives the wire additional stiffness so it better follows as the Extend-A-Gun RC extends or retracts.

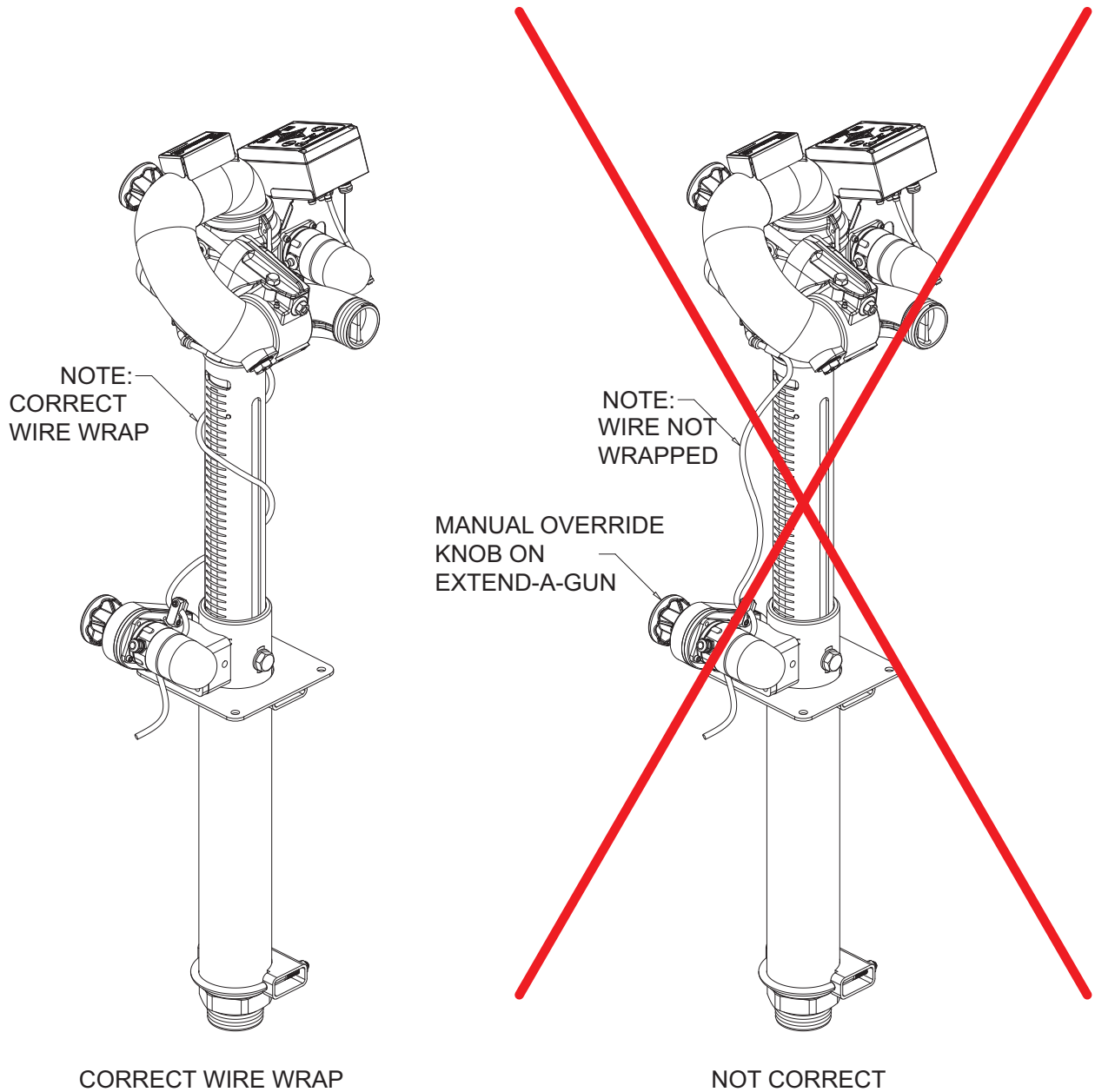

Figure 4.3

The Extend-A-Gun manual override knob may be mounted in any of four possible orientations (90 degrees apart) relative to the Straight Ahead Reference Mark on the monitor.

4.4 HORIZONTAL ROTATION TRAVEL STOPS

The range of horizontal rotation travel for the manual Hurricane monitor is continuous 360 degrees. The motorized version is limited to 450 degrees, or 225 degrees from either side of a straight ahead position. Horizontal (left-right) travel stop bolts may be installed in the monitor to limit travel. Note that left and right are relative to the "Straight Back Reference Mark" and refer to the operator's position behind the monitor, opposite the nozzle's discharge direction. Figure 4.4A and Figure 4.4B show the range of travel for the various stop bolt locations along with installation notes.

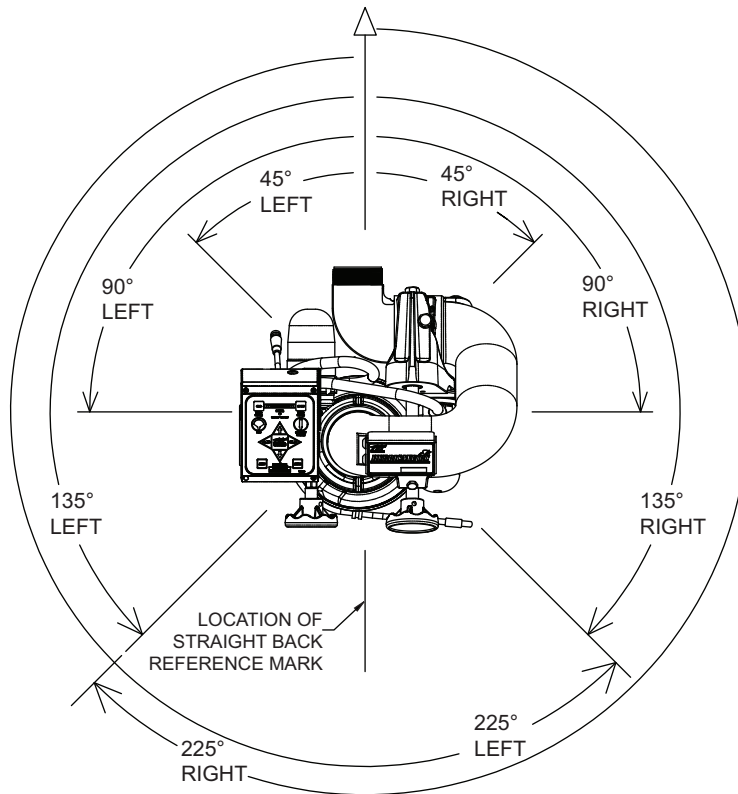

Figure 4.4A

To change the Horizontal Rotational Travel Limits:

1. Remove the Set Screw
2. Insert 1 Adjustment Disc (Not included. Contact tft.com for parts) in the bolt hole for every 10° of travel limitation
3. Replace the Set Screw with the Stop Bolt

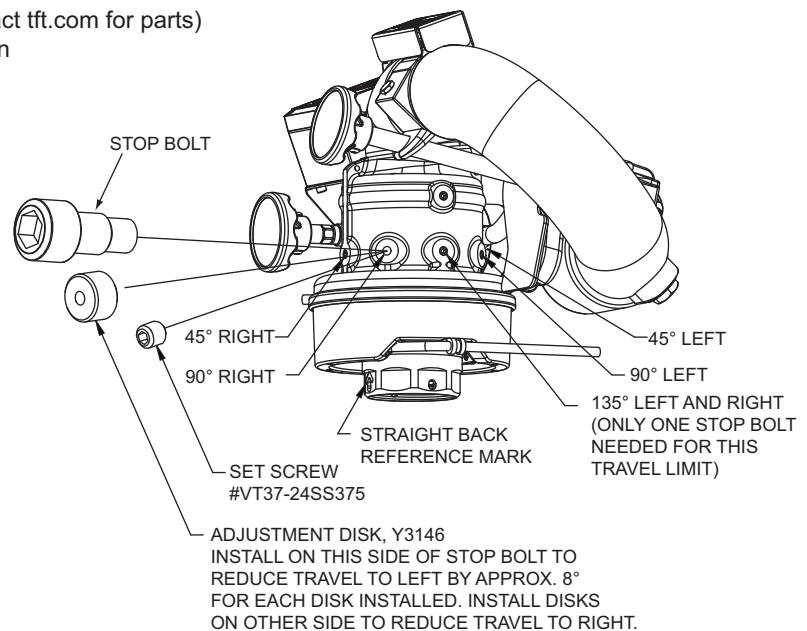

Figure 4.4B

4.5 ELEVATION TRAVEL STOPS

The range of elevation travel for the Hurricane Monitor is 45 degrees past vertical to 45 degrees below horizontal. The elevation range may be limited by installing the supplied stop bolts and adjustment disks at the locations as shown. Consult factory for other ranges. The figures include installation notes.

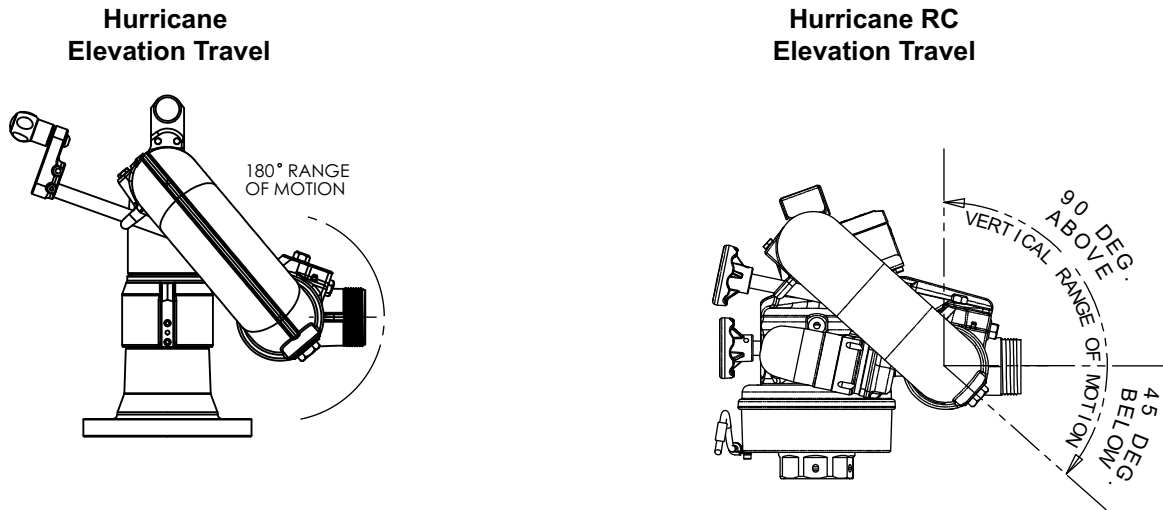

Figure 4.5A

To change the Elevation Travel Limits:

1. Remove the Set Screw
2. Insert 1 Adjustment Disc in the bolt hole for every 10° of travel limitation
3. Replace the Set Screw with the Stop Bolt

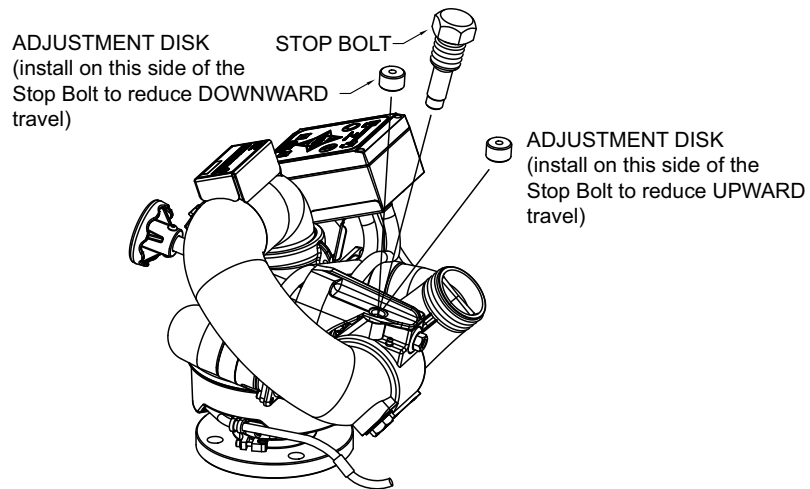

Figure 4.5B

4.6 NOZZLE INSTALLATION

The nozzle is simply screwed onto the monitor's exit threads. If the nozzle is installed on a Hurricane RC (with electric motors) assure that the nozzle's actuator does not make contact with the horizontal drive motor housing when the monitor is in its lowest elevation position.

CAUTION

Mismatched or damaged waterway connections may cause equipment to leak or uncouple under pressure. Failure could result in injury. Equipment must be mated to matched connections.

CAUTION

Dissimilar metals coupled together can cause galvanic corrosion that can result in the inability to uncouple the connection, or complete loss of engagement over time. Failure could cause injury. Per NFPA 1962, if dissimilar metals are left coupled together, an anti-corrosive lubricant should be applied to the connection and the coupling should be disconnected and inspected at least quarterly.

4.6.1 ER NOZZLE INSTALLATION ORIENTATION

For nozzles with electric pattern control, a waterproof connector wire is provided at the bottom outlet of the Hurricane RC's control station box. This wire attaches directly to TFT's electric Masterstream 1250 nozzle. The electric actuator box of nozzle must be oriented to the top side of nozzle for the connection wire to extend 90° above horizontal and 45° below elevation movement.

Monitor Electrical Controls Supplemental Instructions (LIY-500) for properly attaching female to male connectors). Any other nozzle should have the corresponding male electrical connector installed and long enough wire to extend 90° above horizontal and 45° below elevation movement of the nozzle.

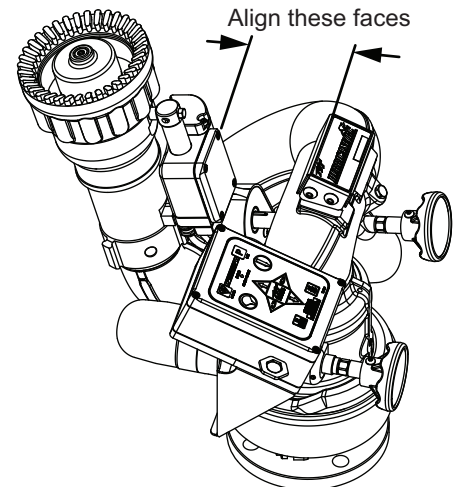

Figure 4.6.1

NOTICE

TFT's Masterstream 1250 ER nozzle's electric actuator box must be on the top side. Align the actuator body and the waterway body to as shown.

NOTICE

DO NOT cut off the female connector on the monitor. This connector is molded onto the wire and must remain intact to maintain the water tightness of the electrical system.

4.7 PRESSURE GAUGE PORT

There is a 1/4" NPT female threaded hole behind the elevation handwheel. The hole is plugged from the factory. If a pressure gauge is desired, unscrew the plug and install the gage using pipe sealant. Make sure the gauge does not interfere with operation.

4.8 AUTOMATIC DRAIN

An automatic drain is included to empty water from a low point in the monitor piping to prevent freezing and help empty hose lines. The valve is designed to close automatically when pressure in the monitor exceeds approximately 5 psi, and open again when the pressure drops to that point.

The automatic drain may be disabled if not desired for your application.

To disable the drain valve:

1. Unscrew the drain assembly and remove the screw and washer.
2. Flip over the rubber drain valve so the raised edge is against the face of the housing.
3. Reassemble the screw and washer using blue Loctite, and reinstall the drain valve assembly.

A secondary drain valve should be installed in the monitor's inlet piping to drain water in the riser.

WARNING

Monitors, valves, and piping may be damaged if frozen while containing sufficient amounts of water. Such damage may be difficult to detect visually and can lead to possible damage, injury, or death. Equipment that may be exposed to freezing conditions must be drained immediately following use to prevent damage.

CAUTION

Structural damage from corrosion can result from failure to drain appliance between uses. Damage from corrosion can cause injury due to equipment failure. Always drain appliance between uses.

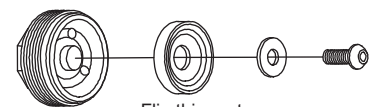

Flip this part over to disable the drain valve.

Figure 4.8

4.9 TILLER/HANDLE INSTALLATION

For manual models, the handle is shipped loose from the monitor and must be installed to complete the installation process. When installing the handle, be sure to coat the threads of the mounting screw with the Loctite supplied in the hardware packet.

5.0 OPERATING INSTRUCTIONS

See Remote Control (RC) Monitor Electrical Controls Supplemental Instructions LIY-500 for operation of the Hurricane RC Monitors.

5.1 HORIZONTAL ROTATIONAL CONTROL

To rotate the Hurricane monitor from side to side on its swivel base:

1. Depending on the model, either lift the rotation lock lever or loosen the rotation lock knob.
2. Rotate the monitor right or left using the handle mounted on to of the monitor.
3. Lock the monitor in position by depressing the rotation lock lever or tightening the rotation lock knob.
4. When the monitor is not in use, the rotation lock lever or rotation lock knob should be kept in the locked position.



Debris in the nozzle may cause off center nozzle reaction. Injury or damage from spinning or sudden movement of the monitor could occur. To reduce the risk of an out of control monitor:

- Always check for waterway obstructions before flowing water
- Always keep the rotation lock tight when not rotating the monitor
- Always keep one hand on the tiller handle when loosening the rotation lock
- When 360° rotation is not needed, install horizontal rotation stop bolts to limit monitor travel

5.2 HANDWHEEL ELEVATION CONTROL

A handwheel controls the monitor's elevation direction. Clockwise rotation of the handwheel lowers the elevation and counterclockwise raises it.

5.3 RECOMMENDED PARK POSITION

For truck mounted applications, it is recommended that the monitor be parked in a position such that the monitor's nozzle rests against a bracket or support surface. If a support surface is not available, run the elevation against one of the travel stops to take some of the backlash out of the gear drive. This will minimize bouncing of the nozzle when the apparatus is traveling. Always be sure the monitor is properly parked before moving the truck and know the overall height to avoid damage from overhead obstructions such as doors or bridges. See LIY-500 for information on programming PARK position.



On many vehicle installations, the monitor is the highest point on the apparatus. Damage or injury could occur if there is not sufficient clearance to safely pass under doors or overhead obstructions. Always check stowed position of the monitor before moving.

5.4 OVERRIDE KNOBS

In the event of electrical system failure on the monitor or fire truck, the Hurricane RC monitor may be manually operated with factory supplied override knobs. To make the Hurricane RC more compact, the manual override knobs may be removed. Removing the override knobs exposes a hex so an 11/16" wrench or socket may be used for manual override. Each drive shaft also has a secondary hex at mid-shaft so the shaft may be shortened by cutting and still have a wrenching hex available.

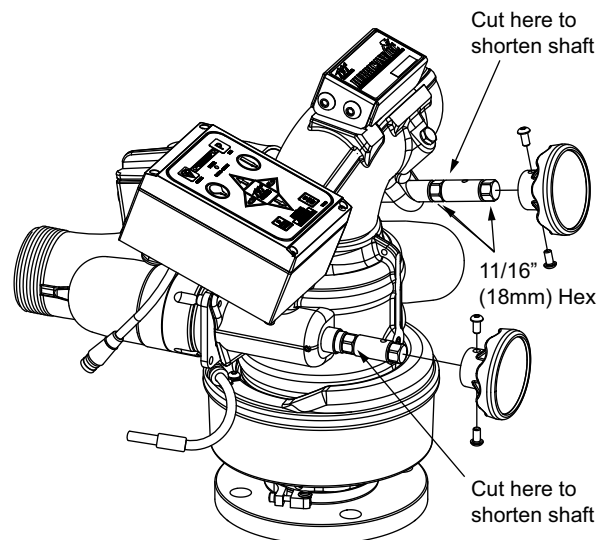

Figure 5.4

6.0 FLOW CHARACTERISTICS

6.1 MST-4NJ STACKED TIPS FLOW AND REACH

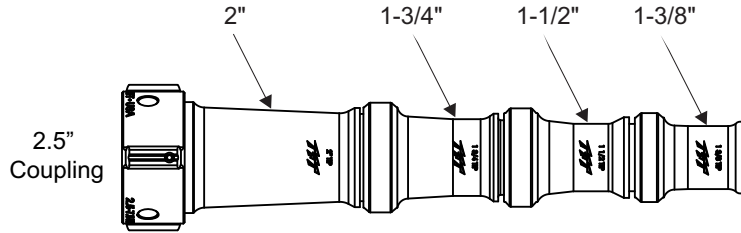

Figure 6.1A

MST-4NJ FLOW/REACTION TABLE

NOZZLE DIAMETER	NOZZLE INLET PRESSURE							
	40 PSI		60 PSI		80 PSI		100 PSI	
	FLOW (GPM)	REACTION (LBS)	FLOW (GPM)	REACTION (LBS)	FLOW (GPM)	REACTION (LBS)	FLOW (GPM)	REACTION (LBS)
1.375"	360	120	440	180	500	240	560	300
1.5"	420	140	520	210	500	280	670	350
1.75"	580	190	700	290	810	380	910	480
2.00"	750	250	920	380	1000	500	1190	630

NOZZLE DIAMETER	NOZZLE INLET PRESSURE							
	2.8 BAR		4.1 BAR		5.5 BAR		7 BAR	
	FLOW (L/min)	REACTION (KG)	FLOW (L/min)	REACTION (KG)	FLOW (L/min)	REACTION (KG)	FLOW (L/min)	REACTION (KG)
35 mm	1360	50	1670	80	1890	110	2120	140
38 mm	1590	60	1970	100	2270	130	2540	160
45 mm	2200	90	2650	130	3070	170	3440	220
50 mm	2840	110	3480	170	4010	230	4500	290

Table 6.1

MST-4NJ FLOW GRAPH

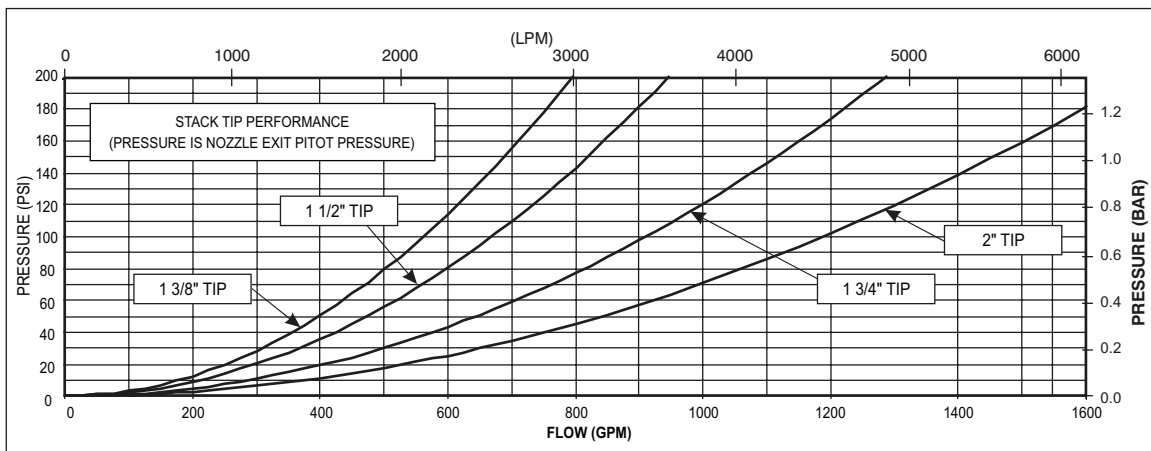

Figure 6.2B

6.1 MST-4NJ STACKED TIPS FLOW AND REACH (CONTINUED)

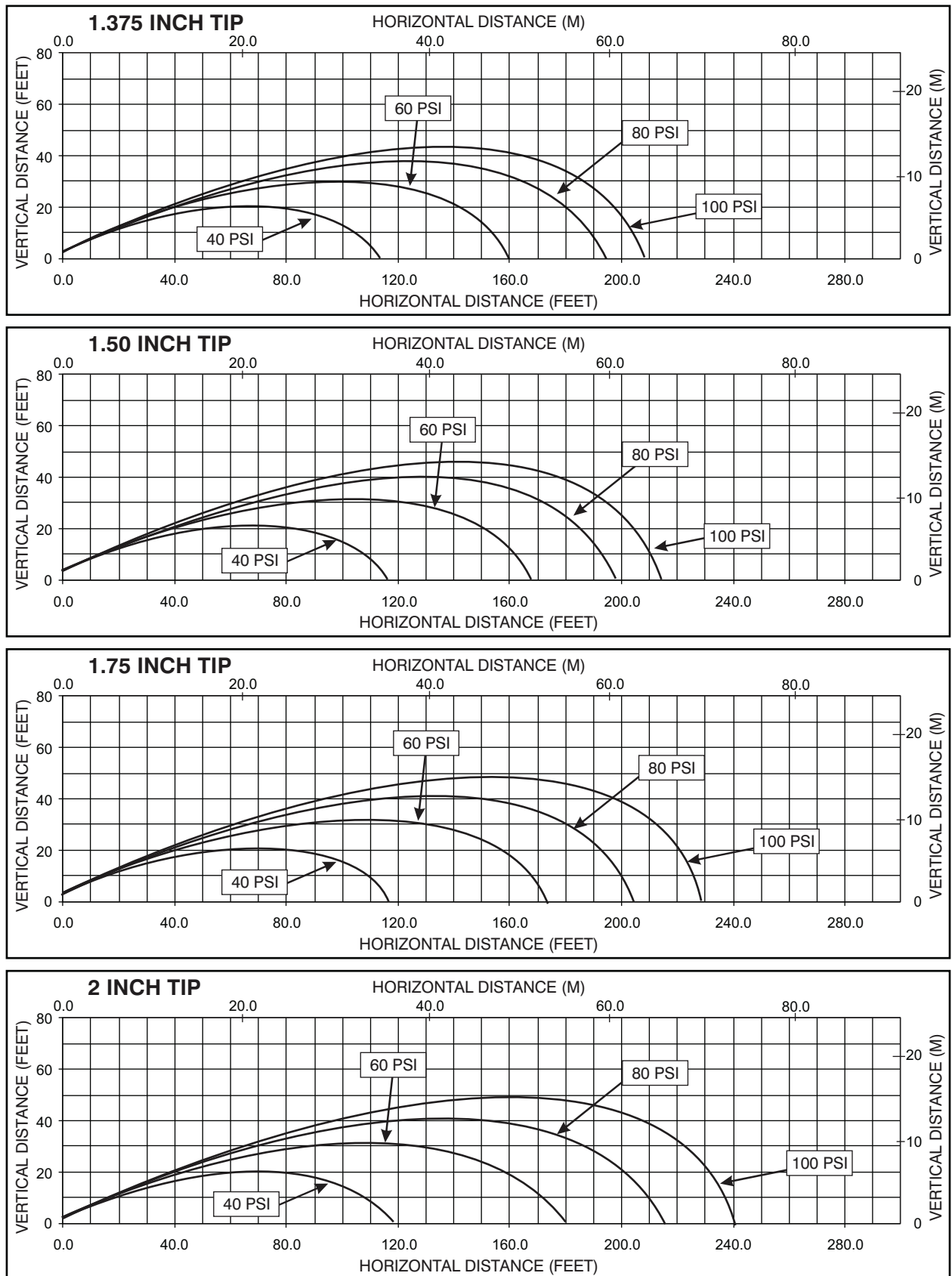

Figure 6.2C

6.1.1 EFFECTS OF ELEVATION ANGLE ON STREAM REACH (2.00" TIP)

This graph shows approximately how differences in elevation angle can affect stream reach. Critical applications should be tested in actual conditions to verify adequate reach.

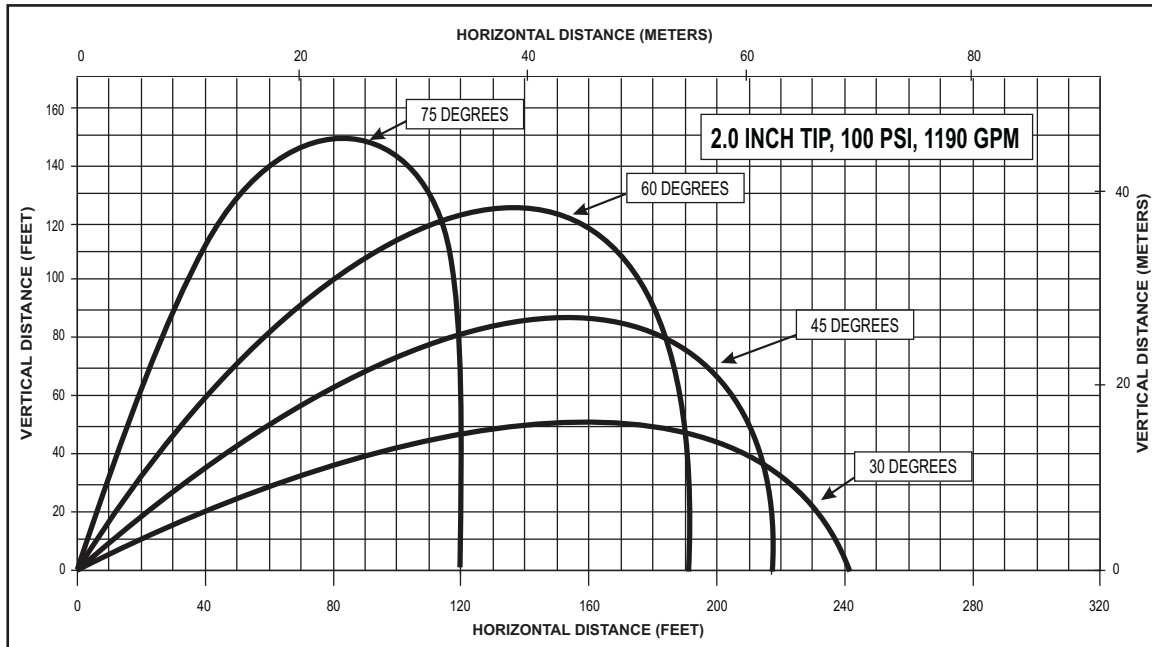

Figure 6.1.1A

This graph shows approximately how a moderate wind can affect stream reach.

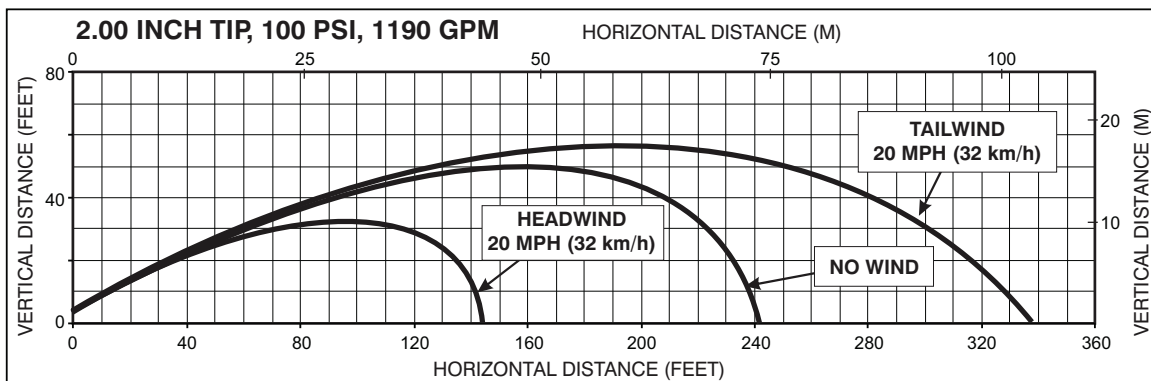

Figure 6.1.1B

6.2 AUTOMATIC MASTERSTREAM NOZZLES

Automatic nozzles maintain a constant pressure by adjusting their orifice to match the available flow. Consult the nozzle manufacturer for maximum flow and pressure range. In all cases, do not exceed the maximum rating of the Hurricane Operating Envelope.

6.3 FRICTION LOSS

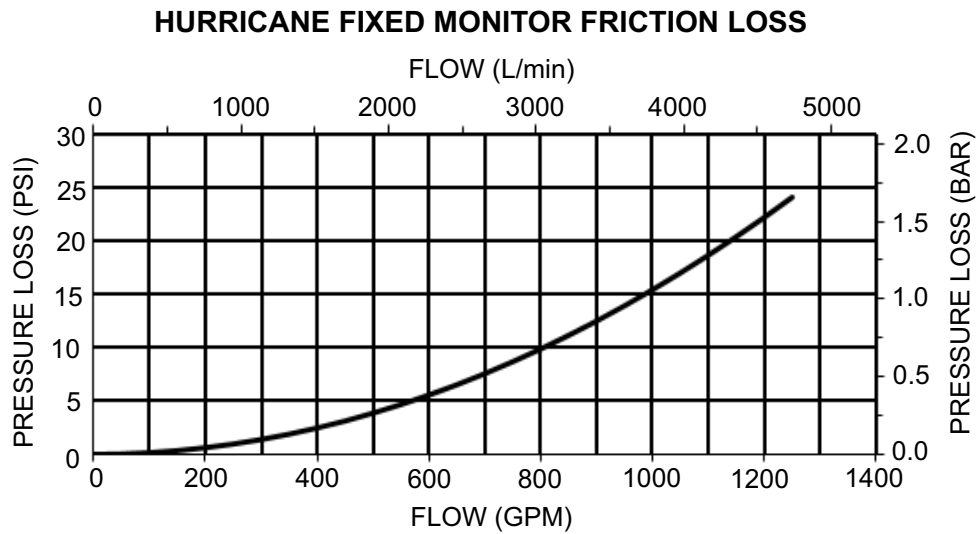

Figure 6.3

6.4 STREAM STRAIGHTENERS

6.4.1 STREAM STRAIGHTENERS WITH STACKED TIPS

Turbulence through the Hurricane Monitor is very low, but stream quality and reach can be improved with the use of the integral stream straightener on the TFT stacked tip nozzle.

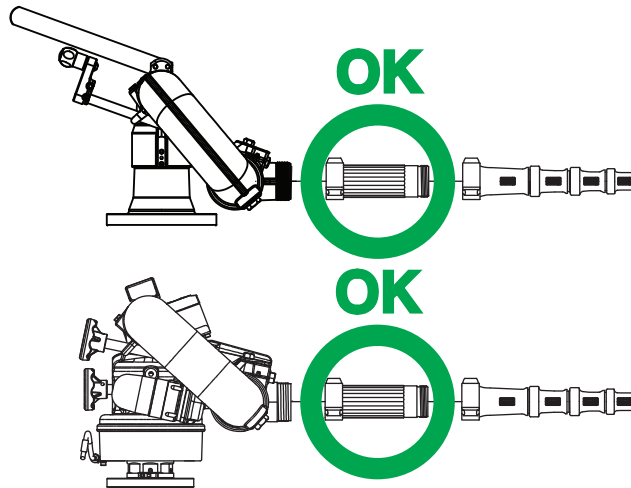

Figure 6.4.1

6.4.2 STREAM STRAIGHTENERS WITH FOG NOZZLES

NOTICE

The flow path of a fog nozzle serves as a stream straightener. Use of a stream straightener with a fog nozzle will increase the stresses on the monitor's gear train and may lead to premature wear. Use of a stream straightener with a fog nozzle is not recommended.

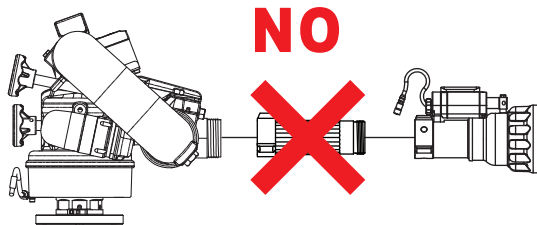

Figure 6.4.2

7.0 WARRANTY

Task Force Tips LLC, 3701 Innovation Way, Valparaiso, Indiana 46383-9327 USA (“TFT”) warrants to the original purchaser of its products (“equipment”), and to anyone to whom it is transferred, that the equipment shall be free from defects in material and workmanship during the five (5) year period from the date of purchase for mechanical components, and the two (2) year period from the date of purchase for electrical components. TFT’s obligation under this warranty is specifically limited to replacing or repairing the equipment (or its parts) which are shown by TFT’s examination to be in a defective condition attributable to TFT. To qualify for this limited warranty, the claimant must return the equipment to TFT, at 3701 Innovation Way, Valparaiso, Indiana 46383-9327 USA, within a reasonable time after discovery of the defect. TFT will examine the equipment. If TFT determines that there is a defect attributable to it, TFT will correct the problem within a reasonable time. If the equipment is covered by this limited warranty, TFT will assume the expenses of repair.

If any defect attributable to TFT under this limited warranty cannot be reasonably cured by repair or replacement, TFT may elect to refund the purchase price of the equipment, less reasonable depreciation, in complete discharge of its obligations under this limited warranty. If TFT makes this election, claimant shall return the equipment to TFT free and clear of any liens and encumbrances.

This is a limited warranty. The original purchaser of the equipment, any person to whom it is transferred, and any person who is an intended or unintended beneficiary of the equipment, shall not be entitled to recover from TFT any consequential or incidental damages for injury to person and/or property resulting from any defective equipment manufactured or assembled by TFT.

It is agreed and understood that the price stated for the equipment is in part consideration for limiting TFT’s liability. Some states do not allow the exclusion or limitation of incidental or consequential damages, so the above may not apply to you.

TFT shall have no obligation under this limited warranty if the equipment is, or has been, misused or neglected (including failure to provide reasonable maintenance) or if there have been accidents to the equipment or if it has been repaired or altered by someone else.

THIS IS A LIMITED EXPRESS WARRANTY ONLY. TFT EXPRESSLY DISCLAIMS WITH RESPECT TO THE EQUIPMENT ALL IMPLIED WARRANTIES OF MERCHANTABILITY AND ALL IMPLIED WARRANTIES OF FITNESS FOR A PARTICULAR PURPOSE. THERE IS NO WARRANTY OF ANY NATURE MADE BY TFT BEYOND THAT STATED IN THIS DOCUMENT.

This limited warranty gives you specific legal rights, and you may also have other rights which vary from state to state.

8.0 MAINTENANCE

TFT products are designed and manufactured to be damage resistant and require minimal maintenance. However, as the primary firefighting tool upon which your life depends, it should be treated accordingly. The unit should be kept clean and free of dirt by rinsing with water after each use. Any inoperable or damaged parts should be repaired or replaced before placing the unit in service. To help prevent mechanical damage, do not drop or throw equipment.

In applications where appliances are left continuously connected to the apparatus or other devices or are used where water is trapped inside the appliance, the appliance must be flushed with fresh water following each use and inspected for damage.

This appliance should be disconnected, cleaned and visually inspected inside and out at least quarterly, or as water quality and use may require. Moving parts such as handles, valve ball and couplings should be checked for smooth and free operation. Seals shall be greased as needed with Silicone based grease such as Molykote 112. Any scrapes that expose bare aluminum should be cleaned and touched up with enamel paint such as Rust-Oleum. Replace any missing or damaged parts before returning to service.

Any equipment taken out of service due to failure should be returned to the factory for repair or replacement. If you have any questions regarding the testing or maintenance of your valve, please call Task Force Tips at 800-348-2686.

8.1 SERVICE TESTING

In accordance with NFPA 1962, equipment must be tested a minimum of annually. Units failing any part of this test must be removed from service, repaired and retested upon completion of the repair.

8.2 LUBRICATION

8.2.1 ELEVATION CONTROL WORM GEAR

In the event that the elevation control operation becomes stiff, grease may be applied to the elevation worm gear grease port. Turn the hand wheel to raise the nozzle to its highest position and pump medium viscosity automotive chassis grease into the grease fitting. Apply only enough grease to restore normal operation. If greasing does not restore normal operation, inspect for other causes of stiff operation.

HURRICANE

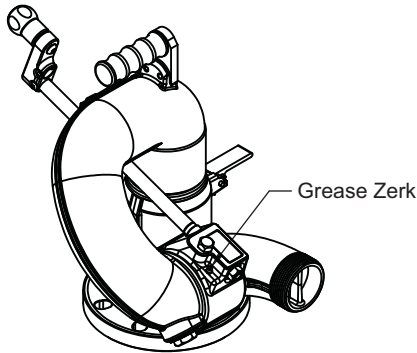

HURRICANE RC

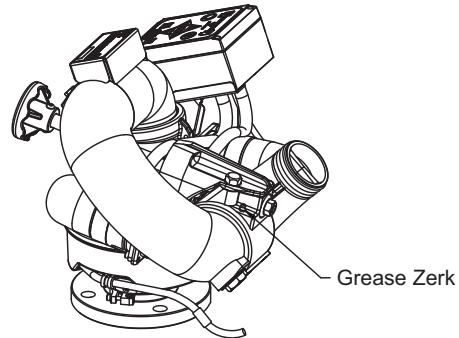

Figure 8.2.1

8.2.2 HORIZONTAL ROTATION WORM GEAR

The Hurricane RC monitor generally should not require greasing in the Horizontal (left-right) worm gear. In the event that the operation becomes stiff, grease may be applied to the horizontal worm gear grease port. Use medium viscosity automotive chassis grease. Apply only enough grease to restore normal operation. If greasing does not restore normal operation, inspect for other causes of stiff operation.

HURRICANE RC

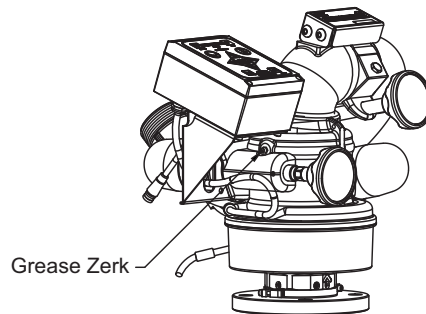

Figure 8.2.2

NOTICE

Do not over pump grease. The monitor's greased areas lead to large chambers that could trap several pounds of grease before becoming visible.

8.3 TROUBLESHOOTING

SYMPTOM	POSSIBLE CAUSE	REMEDY
Leaks	Debris or damage in the seal area	Clean out debris or replace damaged parts
Elevation Binding	Debris or damage to the elevation drive parts	Clean out debris or replace damaged parts
	Lack of lubricant	Grease, (see section 8.2.1)
Horizontal Rotation Binding	Debris or damage to the horizontal drive parts	Clean out debris or replace damaged parts
	Lack of lubricant	Grease, (see section 8.2.2)

8.4 REPAIR

Factory service is available. Factory serviced equipment is repaired by experienced technicians, wet tested to original specifications, and promptly returned. Call TFT service department at 1-800-348-2686 to troubleshoot and, if needed, directions for return. A return for service form can also be obtained at tft.com/Support/Returning-an-Item-for-Service.

Repair parts and service procedures are available for those wishing to perform their own repairs. Task Force Tips assumes no liability for damage to equipment or injury to personnel that is a result of user service. Contact the factory or visit the web site at tft.com for parts lists, exploded views, test procedures and troubleshooting guides.

Performance tests shall be conducted on the equipment after a repair, or anytime a problem is reported to verify operation in accordance with TFT test procedures. Consult factory for the procedure that corresponds to the model and serial number of the equipment. Any equipment which fails the related test criteria should be removed from service immediately. Troubleshooting guides are available with each test procedure or equipment can be returned to the factory for service and testing.

⚠ WARNING

It is the responsibility of service technicians to ensure the use of appropriate protective clothing and equipment. The chosen protective clothing and equipment must provide protection from potential hazards users may encounter while servicing equipment. Requirements for protective clothing and equipment are determined by the Authority Having Jurisdiction (AHJ).

⚠ CAUTION

Any alterations to the product or its markings could diminish safety and constitutes a misuse of this product.

NOTICE

All replacement parts must be obtained from the manufacturer to assure proper performance and operation of the device.

9.0 EXPLODED VIEWS AND PARTS LISTS

Exploded views and parts lists are available at tft.com/serial-number.

10.0 OPERATION AND INSPECTION CHECKLIST

BEFORE EACH USE, appliances must be inspected to this checklist:

1. All valves (if so equipped) open and close fully and smoothly
2. Waterway is clear of obstructions
3. There is no damage to any thread or other connection
4. All locks and hold-down devices work properly
5. The pressure setting on the relief valve (if so equipped) is set correctly
6. Gaskets are in good repair
7. There is no obvious damage such as missing, broken or loose parts
8. There is no damage to the appliance that could impair safe operation (e.g. dents, cracks, corrosion, or other defects)
9. All swiveling elements rotate freely
10. Nozzle is securely attached

BEFORE BEING PLACED BACK IN SERVICE, appliances must be inspected to this checklist:

1. All valves (if so equipped) open and close smoothly and fully
2. The waterway is clear of obstructions
3. There is no damage to any thread or other type connection
4. The pressure setting of the relief valve, if any, is set correctly
5. All locks and hold-down devices work properly
6. Internal gaskets are in accordance with NFPA 1962
7. There is no damage to the appliance that could impair safe operation (e.g. dents, cracks, corrosion, or other defects)
8. All swiveling connections rotate freely
9. There are no missing parts or components
10. The marking for maximum operating pressure is visible
11. There are no missing, broken, or worn lugs on couplings

⚠ WARNING

Equipment failing any part of the checklist is unsafe for use and must have the problem corrected before use or being placed back into service. Operating equipment that has failed the checklist is a misuse of this equipment.